

KENWOOD

100MHz READOUT OSCILLOSCOPE

CS-6010

SERVICE MANUAL

KENWOOD CORPORATION

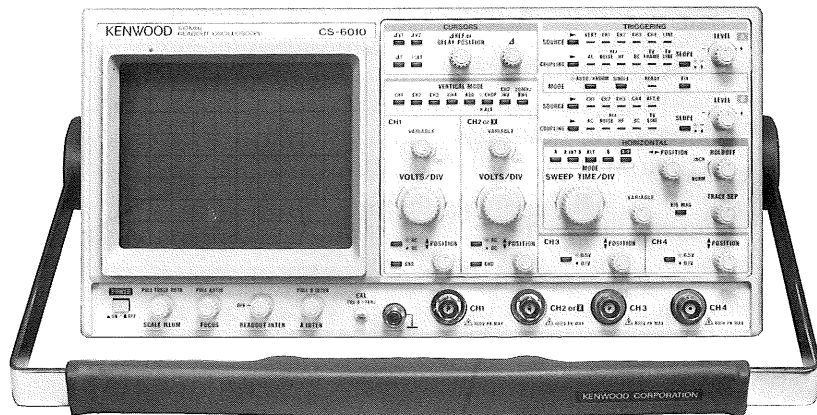

WARNING

1. The following instructions are for use by qualified personnel only. To avoid electric shock, do not perform any servicing other than contained in the operating instructions unless you are qualified to do so.

2. High voltage up to 17000 volts DC is present when the oscilloscope is operating. Line voltage (100 to 240 VAC) is present on the power transformer, on-off switch, fuse holder, and line voltage selector, any time the oscilloscope is connected to an AC power source, even if turned off. Always observe caution whether the AC plug is removed from the AC power source. Contacting exposed high voltage could result in fatal electric shock.

CONTENTS

SPECIFICATIONS	3
SAFETY	6
CIRCUIT DESCRIPTION	7
BLOCK DIAGRAM	13
ADJUSTMENT	14
TROUBLESHOOTING	27
PARTS LIST	59
SCHEMATIC DIAGRAM.....	77
P.C. BOARD	84
DISASSEMBLY	96
SEMICONDUCTORS	97

SPECIFICATIONS

CRT		150 mm rectangular with internal graticule
Acceleration Voltage		17 kV
Display Area		8 × 10 div (1 div = 10 mm)
VERTICAL AXIS (CH1 and CH2)		
Sensitivity		5 mV/div to 5 V/div ± 2% (10 °C to 35 °C) 1 mV/div to 2 V/div ± 4% (10 °C to 35 °C)
Attenuator		12 steps, 1 mV/div to 5 V/div in 1-2-5 sequence Vernier control for fully adjustable sensitivity between steps
Input Impedance		1 MΩ ± 1%, 20 pF ± 3 pF
Frequency Response		
5 mV/div to 5 V/div		DC; DC to 100 MHz, within - 3 dB AC; 5 Hz to 100 MHz, within - 3 dB
1 mV/div, 2 mV/div		DC; DC to 20 MHz, within - 3 dB AC; 5 Hz to 20 MHz, within - 3 dB
Rise Time		3.5 ns or less (5 mV/div to 5 V/div) 17.5 ns or less (1 mV/div, 2 mV/div)
Signal Delay Time		More than 10 ns on the CRT screen
Crosstalk		- 40 dB or less (at 1 kHz)
Operating Modes	CH1	CH1 single trace display, and dual to quad trace display in combination with other channel (s)
	CH2	CH2 single trace display, and dual to quad trace display in combination with other channel (s)
	CH3	CH3 single trace display, and dual to quad trace display in combination with other channel (s)
	CH4	CH4 single trace display, and dual to quad trace display in combination with other channel (s)
	ADD	CH1 + (± CH2) added display, and dual to quad trace display in combination with other channel (s)
	ALT	Dual to quad trace alternating
CHOP		Dual to quad trace chopped
Channel Polarity		Normal or inverted, channel 2 only inverted
Bandwidth Limiting		Approx. 20 MHz
Chop Frequency		Approx. 500 kHz
Delay Time Difference		CH1 to CH2 ; 0.5 ns or less CH1, CH2 to CH3, CH4 ; 1 nsec or less
Non-distorted Maximum Amplitude		More than 8 div (DC to 100 MHz)
⚠ Maximum Input Voltage		800 Vp-p or 400 V (DC + AC peak)
VERTICAL AXIS (CH3 and CH4)		
Sensitivity		0.1 V/div, 0.5 V/div, ± 2% (10 °C to 35 °C)
Input Impedance		1 MΩ ± 1%, 20 pF ± 3 pF
Coupling Method		DC coupling
Frequency Response		DC to 100 MHz, within - 3 dB
Rise Time		3.5 ns or less (at 100 MHz)
⚠ Maximum Input Voltage		800 Vp-p or 400 V (DC + AC peak)
HORIZONTAL AXIS (Input thru CH2)		
Operating Modes		With HORIZ. MODE switch, X-Y operation is selectable CH1 to CH4 and ADD ; Y axis CH2 ; X axis
Sensitivity		Same as vertical axis (CH2)
Input Impedance		Same as vertical axis (CH2)
Frequency Response	DC	DC to 2 MHz, within - 3 dB
	AC	5 Hz to 2 MHz, within - 3 dB
X-Y Phase Difference		3° or less at 100 kHz
Maximum Input Voltage		Same as vertical axis (CH2)

SPECIFICATIONS

SWEEP			
Type	A	A sweep	
	A INT B	B sweep waveform is displayed as an intensified portion of the A sweep.	
	ALT	A sweep (intensified for duration of B sweep) and B sweep (delayed sweep) alternating	
	B	B sweep	
	X-Y	X-Y oscilloscope	
Sweep Time	A	20 ns/div to 0.5 s/div, $\pm 2\%$ (10 °C to 35 °C), in 23 ranges, in 1-2-5 sequence Vernier control provides fully adjustable sweep time all ranges.	
	B	20 ns/div to 5 ms/div, $\pm 2\%$ (10 °C to 35 °C), in 17 ranges, in 1-2-5 sequence Vernier control provides fully adjustable sweep time all ranges.	
Sweep Magnification	$\times 10$ (ten times) $\pm 5\%$ (A and B)		
Linearity	20 ns/div to 0.5 s/div : $\pm 3\%$ ($\pm 5\%$, at $\times 10$ MAG)		
Holdoff	Continuously variable for A sweep from NORM to more than five times		
Trace Separation	B sweep can be separated from A sweep up to 4 divisions downward, continuously adjustable.		
Delay Method	Continuous delay, Trigger delay and Trigger count		
Delay Time	Continuous delay, Trigger delay ; 0.2 to 10 times of A SWEEP TIME/DIV set value (5,000 count fullscale)		
Trigger Count	—		
Delay Accuracy	$\pm (2\% \text{ of set value} + 1\% \text{ of fullscale}) + (0 \text{ to } 100 \text{ ns})$		
Delay Jitter	1/20,000 (A sweep: at 1 ms/div, B sweep: at 1 μ s/div)		
TRIGGERING			
A Trigger Modes	AUTO, NORM, SINGLE, FIX		
A Trigger Source	V. MODE	Triggered by input signal selected with VERTICAL MODE selector	
	CH1	Triggered by CH1 vertical axis input signal	
	CH2	Triggered by CH2 vertical axis input signal	
	CH3	Triggered by CH3 vertical axis input signal	
	CH4	Triggered by CH4 vertical axis input signal	
	LINE	Triggered by line frequency	
A Trigger Coupling	AC, NOISE _{REJ} , HF _{REJ} , DC, TV FRAME, TV LINE		
A Trigger Level	$\pm 90^\circ$ adjustable		
A Trigger Polarity	+/-		
B Trigger Modes	Starts After Delay, B Triggerable After Delay		
B Trigger Source	CH1	Triggered by CH1 vertical axis input signal	
	CH2	Triggered by CH2 vertical axis input signal	
	CH3	Triggered by CH3 vertical axis input signal	
	CH4	Triggered by CH4 vertical axis input signal	
B Trigger Coupling	AC, NOISE _{REJ} , HF _{REJ} , DC, TV LINE		
B Trigger Level	$\pm 90^\circ$ adjustable		
B Trigger Polarity	+/-		
Trigger Sensitivity	COUPLING	FREQUENCY RANGE	MINIMUM SYNC AMPLITUDE
	DC	DC to 50 MHz/DC to 100 MHz	1 div/1.5 div
	AC	20 Hz to 50 MHz/20 Hz to 100 MHz	1 div/1.5 div
	NOISE _{REJ}	Two times of minimum sync amplitude.	
	HF _{REJ}	Increased minimum sync amplitude for above 30 kHz.	
	TV FRAME	1 div (140 IRE)	
	TV LINE	1 div (140 IRE)	
AUTO: Same as above specification for above 50 Hz		FIX: Same as above specification for above 40 Hz.	

SPECIFICATIONS

Jitter		0.5 ns or less at 100 MHz at 2 ns/div sweep rate ($\times 10$ MAG on)
INTENSITY MODULATION		
Input signal		TTL level (more than 2 Vp-p), positive voltage decreases brightness
Input Impedance		Approx. 10 k Ω
Usable Frequency Range		DC to 10 MHz
Maximum Input Voltage		50 V (DC + AC peak)
VERTICAL AXIS OUTPUT (CH1 only)		
Output voltage		Approx. 50 mVp-p/div (into 50 Ω load)
Output Impedance		Approx. 50 Ω
Frequency Response		100 Hz to 100 MHz, within -3 dB (at into 50 Ω)
TRACE ROTATION		Electrical, adjustable from front panel
CALIBRATION VOLTAGE		1 V p-p $\pm 1\%$, Positive square wave, 1 kHz $\pm 3\%$
READOUT		
Calendar		Year/Month/Day/O'clock/Minute Clock accuracy; ± 2 min./month Battery life: About 30,000 hours (at room temperature)
Set Value		CH1 - CH4 scale factor (with probe detection), GND, AC/DC, V-UNCAL, ADD, INVERT, BW, A and B sweep scale factor (magnification conversion), SWEEP VARIABLE UNCAL, X-Y (CH2-X), DELAY TIME
Cursor Mode	$\Delta V1$	Voltage difference between Δ REF and Δ cursors on a CH1 scale factor basis
	$\Delta V2$	Voltage difference between Δ REF and Δ cursors on a CH2 scale factor basis
	ΔT	Time difference between Δ REF and Δ cursors on the basis of sweep scale factor
	$1/\Delta T$	Frequency between Δ REF and Δ cursors on the basis of sweep scale factor
		RATIO: Voltage ratio and time ratio between Δ REF and Δ cursors, supposing 5-division on the CRT as 100% PHASE: Phase difference between Δ REF and Δ cursors, supposing 5-division on the CRT as 360°
Cursor Measurement	Resolution	10 bits
	Measurement accuracy	$\pm 3\%$
	Measurement range	Vertical direction: ± 3.6 div or more from the CRT center Horizontal direction: ± 4.6 div or more from the CRT center
POWER REQUIREMENT		
Line Voltage		100 V/120 V/220 V/240 V AC $\pm 10\%$
Line Frequency		50/60 Hz
Power Consumption		Maximum 75 W
DIMENSIONS (W \times H \times D)		310 (332) \times 150 (163) \times 400 (448) mm () dimensions include protrusion from basic outline dimensions
WEIGHT		Approx. 9.6 kg
ENVIRONMENTAL		
Within Specifications		10°C to 35°C, 85% max. relative humidity
Full Operation		0°C to 40°C, 85% max. relative humidity
ACCESSORIES SUPPLIED		
Probe		PC-31 (READOUT compatible probe) $\times 2$ Attenuation.....1/10 Input impedance.....10 M Ω $\pm 1\%$, 14 pF $\pm 10\%$
Replacement Fuse		1.2 A $\times 2$, 0.8 A $\times 2$
Instruction Manual		1

* Circuit and rating are subject to change without notice due to developments in technology.

SAFETY

SAFETY

Before connecting the instrument to a power source, carefully read the following information, then verify that the proper power cord is used and the proper line fuse is installed for power source. The specified voltage is shown at the fuse holder of the AC inlet. If the power cord is not applied for specified voltage, there is always a certain amount of danger from electric shock.

Line voltage

This instrument operates using ac-power input voltages that 100/120/220/240 V at frequencies from 50 Hz to 60 Hz.

Power cord

The ground wire of the 3-wire ac power plug places the chassis and housing of the oscilloscope at earth ground. Do not attempt to defeat the ground wire connection or float the oscilloscope; to do so may pose a great safety hazard. The appropriate power cord is supplied by an option that is specified when the instrument is ordered. The optional power cords are shown as follows in Fig. 1.

Line fuse

The fuse holder is located on the rear panel and contains the line fuse. Verify that the proper fuse is installed by replacing the line fuse.

Voltage conversion

This oscilloscope may be operated from either a 100 V to 240 V, 50/60 Hz power source. Use the following procedure to change from 100 to 240 volt operation or vice versa.

1. Remove the fuse holder.
2. Replace fuse F 1 with a fuse of appropriate value, 1.2 amp for 100 VAC to 120 VAC operation, 0.8 amp for 220 VAC to 240 VAC operation.
3. Reinsert it for appropriate voltage range.
4. When performing the reinsertion of fuse holder for the voltage conversion, the appropriate power cord should be used. (See Fig. 1.)



Plug configuration	Power cord and plug type	Factory installed instrument fuse	Line cord plug fuse	Parts No. for power cord and plate
	North American 120 volt/60 Hz Rated 15 amp (12 amp max; NEC)	1.2 A, 250 V Fast blow 6 × 30 mm	None	Cord: E30-1820-05
	Universal Europe 220 volt/50 Hz Rated 16 amp	North Europe 0.8 A, 250 V Slow blow 5 × 20 mm	None	Cord: E30-1819-05
		Other Europe 0.8 A, 250 V Fast blow 6 × 30 mm		
	U.K. 240 volt/50 Hz Rated 13 amp	0.8 A, 250 V Fast blow 6 × 30 mm	0.8 A Type C	—
	Australian 240 volt/50 Hz Rated 10 amp	0.8 A, 250 V Fast blow 6 × 30 mm	None	Cord: E30-1821-05
	North American 240 volt/60 Hz Rated 15 amp (12 amp max; NEC)	0.8 A, 250 V Fast blow 6 × 30 mm	None	—
	Switzerland 240 volt/50 Hz Rated 10 amp	0.8 A, 250 V Fast blow 6 × 30 mm	None	—

Fig. 1 Power Input Voltage Configuration

CIRCUIT DESCRIPTION

Vertical Attenuator Circuit (X75-1180-00)

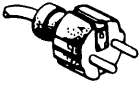
The attenuators for channel 1 and channel 2 are operated by the signals from the panel, and AC/DC/GND input coupling and attenuation of 1/1, 1/10, and 1/100 are switched.

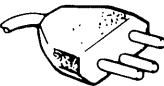
The vertical input signal from the BNC input terminal passes through the attenuator and is input to the buffer amp formed by U101 and Q101 (CH2: U201 and Q201). U101 is a source follower and constant current supply and Q101 is for input protection. The input signal is impedance converted by these components and is input to the 1st amp formed by U102 and Q102 (CH2: U202, Q202). A differential signal is created here, and the 1st amp for channel 2 contains an INV circuit which switches the inversion transistor ON/OFF using the data from the R/O unit.

U1 and U2 produce a voltage signal from the serial data from the R/O unit, and this serial data is converted to a 0/5 V parallel signal. Although inversion is not possible on the channel 1 side, the same circuit as the channel 2 circuit is used for circuit stability, and the bias of the inversion transistor is fixed at the off state. The channels 1 and 2 input signals are input to the vertical preamp unit after passing through the 1st amp.

The channels 3 and 4 input signals are input to the 1/1 or 1/5 attenuator as selected by the K301 (CH4 : K401) relay. The signal is then input to the buffer amp formed by Q301 and 302 (CH4: Q401, 402). Q301 is a source follower, Q302 is a constant current supply, and Q303 is for input protection. The signal is impedance converted by this amp. The signal is then input to the 1st amp formed by Q304 and 305 (CH4: Q404, 405). This amplifier produces a differential signal. The channel 3 and channel 4 signals are input to the vertical preamp unit after passing through the 1st amp.

Switch Unit (X69-1150-01)

* Switch Matrix

All of the contact switches on the panel form a switch matrix. Pins 1, 2, 3, 4, and 15 of U9 are all low when a contact switch is not pressed, and the output (D0 to D7) is at +5 V.

When a switch is pressed, the output of the switch (one of D0 through D7) goes to low due to Pin 15, 1, 2, 3, or 4 of U9 going to low. The output from D0 through D7 is connected to the R/O unit, and when any of these outputs goes to low, an interrupt is applied to the CPU and serial data is sent to U9. U9 which receives data from the R/O unit, first switches all of Pins 15, 1, 2, 3, and 4 to high and

then switches each pin to low. The resulting voltage from the output (D0 to D7) is used to determine which switch was pressed.

* Panel LED

The corresponding LEDs on the panel are illuminated when Pins 15 and 1 through 7 of U2 through U8 go from high to low. Serial data from the R/O unit is sent to U2 through U8, and the LED to be illuminated is selected according to that signal.

* Rotary Encoder

Rotary encoders are used for the VOLTS/DIV and SWEEP TIME controls for channel 1 and channel 2. The data from these encoders is received by the R/O unit. Refer to the section on the R/O unit regarding operation.

Panel Unit (X66-1050-00)

* VR (VR1 to 10), Uncal Search

Variable resistors (VR) are used for setting the position, V-variable, trig level, hold off, and T-sep for each channel. Both terminals of each of the VRs are connected to +/- 10 V, +10 V-GND, or +5 V and GND, and the set voltage is sent to the various units.

The collector of Q1, 2 (CH1) or Q3, 4 (CH2) goes from 0 V to approximately +5 V when V-VARIABLE is set to the UNCAL state, voltage is supplied to the R/O unit, and the UNCAL mark (●) appears on the screen.

* Comparator, Endless VR

Endless VRs are used in four locations: horizontal variable, horizontal position, Δ , and Δ REF. As shown in Fig. 1, two resistance elements are used alternately for this operation. The output voltage is received by the R/O unit. U1a supplies stable voltage to each terminal of the endless VRs.

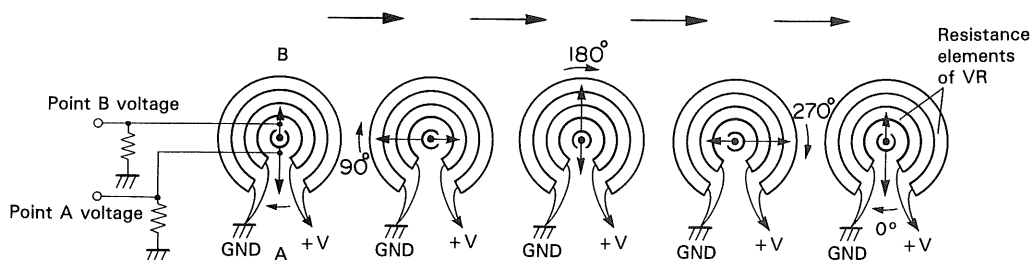

CIRCUIT DESCRIPTION

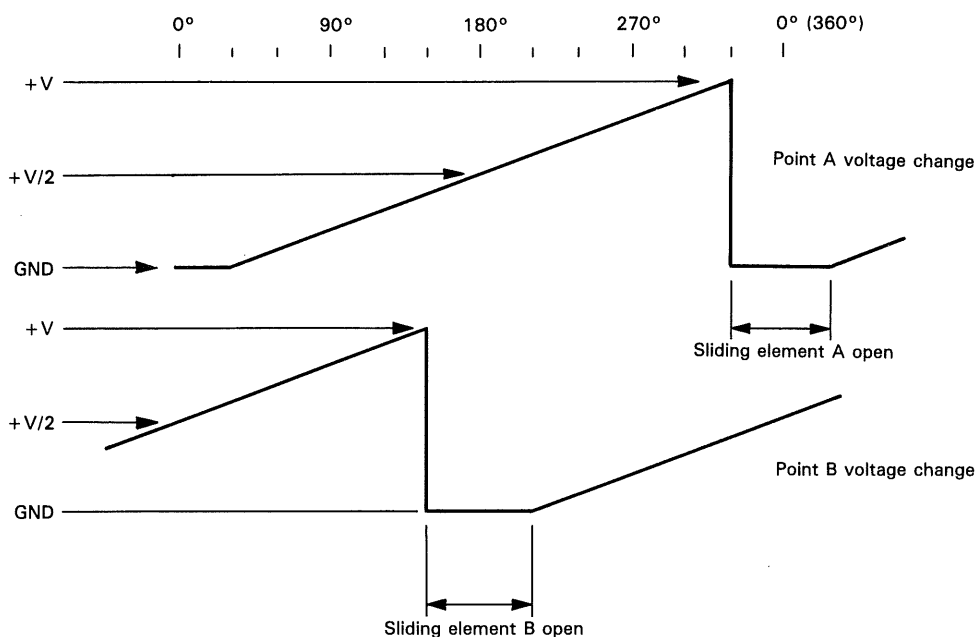

Fig. 1 Endless VR Operation

High Voltage Unit (X68-1510-01)

* Blanking Circuit

This is a circuit for amplifying the blanking signal from the horizontal unit. The signal input from P19 passes through the Q8 emitter follower, and is input to Q6 for amplification. Q5 is a constant current supply for Q6 and Q7 is a transistor for absorbing current. Negative feedback is applied to this by R26, and the degree of amplification is determined by R26 and R358 of the horizontal unit. The blanking signal amplified to high voltage is then applied to G1 of the CRT from the high voltage oscillation circuit (described below) using D8 through D10. The G1 potential from K (cathode) is set a low level, and the brightness decreases as this level decreases.

The voltage of the blanking signal of the horizontal unit is altered according to the INT VR of the VR unit, altering the brightness which results.

The output from Q6, i.e., the amplified blanking signal, is input to Q4. The brightness is altered by the auto-focus so that the focus point is not lost.

Q3 is a constant current supply for Q4. The signal is then overlapped with the high voltage level using D4 through 7, in the same manner, and the resulting signal is applied to the P1 terminal of the CRT after the potential is controlled by VR23 of the VR unit.

* High Voltage Oscillation Circuit

Oscillation at 30 kHz is invoked by Q1, and becomes high voltage by the high voltage block. U1 and Q2 provide negative feedback for control.

Power Supply Unit (X68-1500-00)

The power supply circuit is comprised of six regulated output systems (+5, +/− 10, +15, +60, and +140 V) and two unregulated systems (+/− 13 V).

The regulated outputs are all with reference to −10 V. This −10 V output uses a 5 V Zener diode (D5) as reference, and is obtained by the drive transistor (Q6) and op amp U3. Other regulated output is obtained using op amps (U1, 2, and 3) and transistors (Q1, 3, 5, 6, 7, and 8), with this −10 V output as reference.

The unregulated output of +/− 13 V uses the voltage before regulation to obtain regulated output of +/− 10 V.

VR Unit (X81-2330-01)

* Calibration Voltage Generation Circuit

Op amp U1 is used as an oscillator, and the DC voltage is switched using D1 to generate a 1kHz square wave.

* Scale Illumination Circuit

This circuit drives an illumination lamp with the Q6 emitter follower as an output stage. D4 and 5 are used for switching to provide one-shot illumination.

* Trace Rotation Circuit

This circuit drives a coil for rotation by the Q2 and 3 emitter followers.

* Intensity Circuit

This circuit has three 20KB VRs, A SWEEP, B SWEEP, and R/O, both ends are connected to +/− 10 V, and the set voltage is sent to the horizontal unit to create a blanking signal. The R/O VR is equipped with an ON/OFF switch.

CIRCUIT DESCRIPTION

Final Unit (X80-1100-01)

* Vertical Amplification System — Vertical Final Preamp to Vertical R/O Switching to Vertical Final Amp

The signal output from the vertical preamp unit and which passed through the delay line, is input to the vertical amplification system of the final unit. The signal first passes through the Q1 and Q2 emitter followers, and is input to Q3 and Q4 for amplification. Q203 and 204 alternately select Q3 and Q4 which amplify the waveform for output of characters on the CRT screen by the R/O function and Q201 and Q202 which amplify the character information sent from the R/O unit. When the ROREQ signal from the R/O unit is high, Q204 is switched ON, Q3 and 4 are switched ON, Q203 is switched OFF, and Q201 and 202 are switched OFF. The signal is amplified and the character information is not input. When the ROREQ signal is low, the opposite occurs, and the character information is amplified without signal input. The signal then enters the Q5 and 6 base grounded amp, is impedance converted by the Q7 and 8 emitter follower, is input to the final amp formed by Q9, 10, 13, 11, 12, and 14, and is input to the deflection plate of the CRT.

* Horizontal Amplification System — Horizontal Final Preamp to Horizontal R/O Switching to Horizontal Final Amp

The signal sent from the horizontal unit is input to the Q101, 102 base grounded amp, and is amplified by Q103, 104 after passing through D101, 102, 105 and 106 for excessive input limiting. In the same manner as the vertical system, Q208, 209 switches between the amp for signal formed by Q103, 104 and the amp for characters formed by Q206, 207.

Following this, the signal is input to the Q105, 106 base grounded amp, is impedance converted by the Q107, 108 emitter follower, is amplified by Q109, 110, is impedance converted by the Q112, 113 emitter follower, and is input to the Q114, 115 amp. Q116, 117 form a constant current supply to supply a fixed current level to Q114, 115. Negative feedback is applied to the output by R114, 145, 153, and 154, and the degree of amplification is determined by R144, 145, 153, 154 and R152, 133. This configuration provides stability and allows for amplification with high amplitude.

Vertical Preamp Unit (X73-1760-00)

The channel 1 and channel 2 signals output from the ATT unit enter the vertical preamp unit and are first input to the buffer amp formed by Q101 (CH2: Q201). The signals are then input to the X5 and X1 amps. The X5 amp is formed by Q102 (CH2: Q202) and the X1 amp by Q103 and 104 (CH2: Q203, 204). Switching between the amps is by Q105 and 106. When Q105 is ON, Q106 is OFF and the X5 amp is selected. When Q106 is ON, Q105 is OFF and the X1 amp is selected. The signal which passed through Q108, 109 (CH2: Q208, 209) cascode connected to Q102, 103, 104 (CH2: Q202, 203, 204) is input to the 1/1, 1/2, or 1/4 ATT, switched by the K101 (CH2: K201) relay. The signal emerging from the ATT is impedance converted by Q112, 113 (CH2: Q21, 213), and input to Q114, 115 (CH2: Q214, 215). There is a vertical variable circuit formed by R169,

170, D103, 104, 150, 151, 152, 153, 154, and 155 (CH2: R269, 270, D203, 204, 250, 251, 252, 253, 254, and 255) between the cascode connections. This circuit applies the DC signal for variable control sent from the panel by V101 (CH2: V201) to the cathode of the diode to divert the current, altering the diode impedance to vary the gain.

The CH1 and CH2 signals emerging from the cascode amp which forms the 3rd amp are impedance converted by the buffer amp formed by Q119, 120 (CH2: 219, 220), and input to the amp for trig signal output (formed by Q601 to 604), Q528 and 529 cascode connected to Q501 and 502. Between the cascode amps, there is an amp for POSI variation by Q503, Q504 (CH2: Q507, 508) and a CH selection circuit formed by Q1 and 2 (CH2: Q3, 4). Although the trigger signal output amp is a balanced circuit using Q601 and 602 (CH2: 605, 606), only Q601 (CH2: Q605) actually extracts the trigger signal, and this component is cascode connected to Q603 (CH2: Q607). Subsequent explanation on this trigger amp will be given below.

* CH3 and 4 3rd Amp to Select SW

Q301 and 302 (CH4: Q401, 402) are cascode connected to Q304 and 305 (CH4: 404, 405) of the attenuator unit, and there are resistors and capacitors for gain control and frequency response correction between them. The signal emerging from the cascode amp enters the buffer amp formed by Q304, 305 (CH4: Q404, 405), is impedance converted, and input to the 1st trig amp.

The input to the trig amp is approximately 50% of the output from the 3rd amp, and a balance circuit is formed by Q609 and 610 (CH4: Q613, 614) for balancing. However, the signal extracted as the trigger signal is actually only the signal from the Q609 side (CH4: Q613). Subsequent explanation on this trigger amp will be given below.

The signal output from the 3rd amp will be input to the trig amp and V. mode select switch. This is formed by Q509, 510 (CH4: Q513, 514) and Q5, 6 (CH4: Q7, 8). When the V. mode is selected, Q5, 6 (CH4: : Q7, 8) are OFF, and the signal passes through D505, 506 (CH4: D507, 508), and is input to the mix amp. When this mode is not selected, Q5, 6 (CH4: Q7, 8) are ON, and the signal is cancelled. This operation is the same for channels 1 and 2. Q511, 512 (CH4: Q515, 516) between Q509, 510 (CH4: Q513, 514) and Q5, 6 (CH4: Q7, 8) form a POSI variable amp which changes the bias of Q512 (CH4: Q516) to vary the position, according to the DC voltage from the panel.

* Mix Amp to 4-ch Amp to T. SEP Amp to 20 MHz BW SW

The signals which passed through the select switches for the various channels and diodes D501 through 508, are input to the mix amp formed by Q528, 529. Q518 is ON when ADD is selected in the V. mode. The impedance of the signal is then converted by the buffer amp formed by Q519, 520, and input to the T. SEP amp formed by Q522 and 523. In this T. SEP amp, the B SWEEP position is altered by input of a control signal to the base of Q523 for switching so that the amp only operates by the B sweep signal. The impedance of the signal which passed through the T. SEP amp is converted by the buffer amp formed by Q524, 525, and the signal is input to the delay line. A switch for performing 20 MHz BW is formed by Q526, 527, a low-pass

CIRCUIT DESCRIPTION

filter is formed by C509, 510, and the circuit functions as a 20 MHz BW. The signal then passes through a delay line and is input to the final unit.

* 1st Trig Amp — Trig Select — 2nd Trig Amp

The trigger signal extracted by Q601 and 602 (CH1), Q605 and 606 (CH2), Q609 and 610 (CH3), and Q613 and 614 (CH4) is input to the amps formed by Q603 and 604 (CH1), Q607 and 608 (CH2), Q611 and 612 (CH3), and Q615 and 616 (CH4). It is then input to trig select after impedance conversion. At this time, a portion of the channel 1 signal is split to the CH1 out amp formed by Q621 and 622, and a portion of the channel 2 passes through Q620 and becomes the X signal for the X-Y mode.

Trig select is a switch formed by D601, 602, 603, and Q623 to 621. When the various transistors are switched on by the CH select logic signal, the diode connected to the transistor has reverse polarity and goes off. The diode can be switched on by switching the transistor off, and the trigger signal will be output to the amp in the next stage. D601 receives the A trig, D602 receives the B trig, and D603 receives the line trig.

The trigger signal received by trig select is impedance converted by the 2nd trig amp formed by Q617 and 632 (A trig) and Q618 and 633 (B trig), and is then sent to the horizontal unit.

* Control of vertical preamp unit

The following signals are sent from the R/O unit for control of the vertical preamp unit.

(1) Serial data this signal is sent from the R/O unit together with the clock signal, and input to U1, U2, U3, U4, U5, U6, U7, and U8 for conversion to parallel data.

The following are controlled by this signal:

- X1 and X5 amp switching
- 1/1, 1/2, 1/4 ATT switching
- V-MODE switching
- 20 MHz BW limit
- Trigger signal selection

(2) Voltage supplied directly from panel voltage between 0 V and 10 V is created by the variable resistors on the panel, and is input as a signal to the vertical preamp unit through the R/O unit.

- POSI variation
- V-VAR

The above are the signals externally input for control.

Horizontal Unit (X74-1480-01)

The trigger signals (ATR, BTR signal) supplied from the vertical preamp unit (X73-1760-00) are input to the trig preamps. The A trig preamp is formed from Q1 and Q2, etc., and the B trig preamp is formed from Q14 and Q15, etc. When a TV signal is input, TV coupling is selected to amplify the TV sync signal. The control signal to perform this is output from U29, and the gain of Q1 and Q14 is changed by switching with Q9 to correspond to the TV sync signal. The trigger level is altered after the signal passes through the trig preamp. The trigger level of A-sweep is altered by U21 and the level of B-sweep by U22. The level is switched by the U16 analog switch by panel switch operation, and the FIX signal, TV signal, and A BLVL signal are selected.

The input signal with trigger level altered is input to the trig amp formed by Q5, Q6, Q7 and Q17, Q18, and Q19. When coupling is set to HF_{REJ} by operation of the panel switch, a control signal is output from U29, Q8 or Q20 is switched on, and the high frequency components are attenuated. The signal is input to the Schmitt circuit formed by U1 or U2 after passing through the trig amp. The hysteresis width of the Schmitt circuit is altered by the noise rejection control signal output from U29, allowing stable triggering even for input signals containing noise. The control signal output from U30 determines whether the slope is positive or negative. The signal output from the A-sweep Schmitt circuit is input to the auto freerun circuit formed by Q103 and Q104 to control U39 according to the auto or normal mode. This sets the unit to the sweep mode or trigger standby mode. The AS signal output from Q of U3a is input to Q109 of the A-sweep circuit, performing start and stop control of the A-sweep. U24b in the A-sweep circuit takes the analog voltage supplied from the R/O unit and amplifies it to 5 V at range 1, 2.5 V at range 2, and 1 V at range 5. The current is determined by this voltage and the aggregate resistance selected by the U17 analog switch. This determines the sweep time.

The AS signal output from Q of U3a and the BS signal output from Q of U3b are input to the blanking circuit formed by U4, the UNBL signal is generated from ROUBL, ROINT, BINT, AINT, etc., and supplied to the high voltage unit (X68-1510-01).

In the same manner as the A-sweep circuit, U26D in the B-sweep circuit amplifies the analog voltage fed from the R/O unit, and determines the current by the U18 analog switch to determine the sweep time.

The A-sweep signal output from Q116 and the B-sweep signal output from Q134 are input to the mix amp formed by U19, Q302, Q303, Q304, Q306, and Q307. In this circuit, the analog voltage supplied from X10 MAG and the R/O unit are amplified by U27, and H-POSI control is performed. The signals output from this circuit are fed to the final unit (X80-1100-01) as the X+ and X- signals.

Switching between A-sweep and B-sweep is controlled by U7, and this signal is sent to the mix amp and blanking circuit. The switching signal for chopping of A-sweep and B-sweep is generated by the circuit formed by Q403 and Q404. The chop frequency at this time is 500 kHz.

Delayed sweep is performed by comparing the voltage of the A-sweep output from Q116 and the DTP signal supplied from the R/O unit by the delay comparator formed by Q102, U25, etc, and the position to start the B-sweep is determined. The signal to start the B-sweep at this time is input to the logic circuit for B-sweep formed by U13a, b, c, and U6, and the signal to output the BS signal is sent to U3b. In the single sweep mode, the SGL signal supplied from the R/O unit is input to the A-sweep logic circuit formed by U11b, U12d, and U5, and the A-sweep trigger standby mode is selected when the RESET signal is input.

There is also a 1-shot ILLM circuit which illuminates a lamp for approximately 1 second when the single sweep is completed. This circuit is formed from U12, Q405, Q406, C405, and C406, etc.

CIRCUIT DESCRIPTION

Readout unit (X77-1490-00)

The R/O unit contains an 8-bit Z-80A CPU, and has two major functions: control of the operation of the various sections and the output of CRT character information.

The basic clock which forms the basis for the timing of all IC operations is generated by the 10 MHz oscillator formed by U11d and X1. The 10 MHz CLK is used for operation of U33 (R/O controller), and this clock signal is divided to 1/4 by U10 to create the 2.5 MHz CLK. This clock signal is used for operation of the U5 CPU (Z-80A) and as a control signal for sending data and addresses to U33.

Changes in information from the switch unit (X69-1150-01) and the timing, clock, and soft timers for the CRT display are all realized through interrupts which are sent to the CPU. Changes at the switch unit include interrupts issued when a pushbutton switch is pressed and when the rotary encoders used for VOLTS/DIV and SWEEP/DIV are rotated. When a switch is pressed, one of lines D0 through D7 of U24 connected as a data bus for switch information goes to "L". U14e goes to "L" causing Q of U21a to also go to "L", notifying the CPU that a switch position has been changed. When CRT information is changed by operation of the switches or variable resistors on the panel, the timing for updating the CRT indication is output every 13.5 μ s from U33. The change is latched to U21a, and indicated to the CPU as an interrupt. The CPU recognizes this interrupt and performs processing to update the CRT indication.

U12, U13, U17, and U18 form the inport section which outputs the data decoded by U6 and U8 to the data bus. U12 is an inport IC for evaluating the probe detection (1/1 to 1/10), battery capacity, and status of the CH1 and CH2 variables. Probe detection and variable status are fetched by the CPU approximately every 15 μ s, and evaluated and processing performed. The B1 battery capacity is monitored by U46a, and when the level drops below approximately 2.4 V, the status (H level) is fetched from the inport at POWER ON, and "BATT DOWN" is displayed on the CRT screen. U13 is an inport IC for interrupt evaluation, and it determines whether an interrupt such as rotary encoder (CH1, CH2, SWEEP), 2 msec, clock, switch, or CRT indication has been transmitted to the CPU.

U17 receives the A-phase and B-phase status of the rotary encoder, receives and evaluates the movement of the endless VR, and receives and evaluates the single ready state. Reception and evaluation of the endless VR movement is made by having U35 compare the endless VR voltage and D/A convertor (U37) voltage, to determine whether the endless VR has been rotated. U18 is an IC for fetching data from the panel switches, and it receives the state when a switch is pressed.

U6 through U9 are a decoder circuit, and U6 uses PAL. The PAL has a circuit configuration capable of decoding the inport and output clocks, ROM, and RAM. U7 through U9 decode individual information selected by U9.

U8 outputs the decoded information from inport U12, 13, 17, and 18, and the latch CLK (VLC, HLC, ALC, and LLC) for serial transfer.

U19 outputs the latch CLK (SLC) for serial transfer and the shift CLK (ASC, LSC, SSC, HSC, VSC).

U7 outputs the data latch CLK for serial transfers, the interrupt latches (U20, U21, U22, and U23), and the RESET

pulse. The data latch CLK is also used as the CLK for latching the data for serial transfers by U16.

A blanking signal is applied during serial transfer to prevent the effects of noise on the waveform. This blanking is output from Pin 21 of U33.

U1 is RAM, and 2 K \times 8 bit memory is used. This SRAM is backed up by B1 when the power is off, and the power is switched by U19 when the power is turned on/off. Switching is performed by the U4 power reset IC, and a reset signal is supplied to U3, U5, and U19 at 4.4V \pm 0.2 V. U2 is a software ROM, and both 16 K and 32 K can be used by switching by R128 and R256.

Although CTM5020 (U33) can be directly connected to 8080-type CPUs, direct connection of address and data is not possible with the Z-80 due to the absence of an ALE terminal. For this reason an ALE signal is generated by the ADD/DATA SELE circuit formed by U27, U28, U23b, U14b and d, U25b, and U29c to allow connection with U33.

The software timer needed for CPU operation is created by U26 as a 2 ms timer. This is latched to U20a every 2 ms to indicate an interrupt to the CPU.

U3 is backed up by lithium battery B1 when the power is off, and the 32.768 kHz basic clock from the crystal oscillator operates. An interrupt signal is output from U3 once every minute, and is latched to U20b. The calendar indication on the CRT is advanced one minute by the input of this interrupt.

The U37 D/A convertor creates the voltage output for endless VR comparison, the analog control voltage used by the horizontal unit (X74-1480-01), and the cursor control voltage. The latter control voltage is switched by the U41 analog switch, and is output once every 4 ms by time division. This output control is performed by AX0 through AX3 of U33, and AX3 is a control terminal to prevent the comparison voltage being output to the control voltage when this voltage for endless VR comparison is output from the U37 D/A convertor.

The cursor control voltage (Δ and Δ REF) output from U41 is switched with R/O-Y and R/O-X by the U40 and 43 analog switches, and output to the final amp.

There are analog control voltages used by the horizontal unit: A-vari, B-vari, DTP, and H-posi.

A-vari and B-vari output the reference voltages for sweep A and sweep B, and the voltage determined by the 1-2-5 range is output (during CAL). During UNCAL, the A-vari and B-vari voltage changes and the sweep time changes. At this time, the voltage is changed so that the amount of variation changes at the various ranges so that variation rate corresponds to the rotational speed of the endless VR. The count distribution is 2000 for range 1, 1000 for range 2, and 400 for range 5, and the amount of change per step is altered every 10, 6, and 2 counts respectively. A-vari passes through the U47b buffer amp with the voltage level maintained by the hold circuit and B-vari passes through the U47a buffer amp before both are fed to the horizontal unit (X74-1480-01).

The following is a description of the operation of the rotary encoder used for switching volts/div and sweep time. The rotary encoder has two outputs, and rotation to the right or left is determined by the output resulting from the phase difference.

CIRCUIT DESCRIPTION

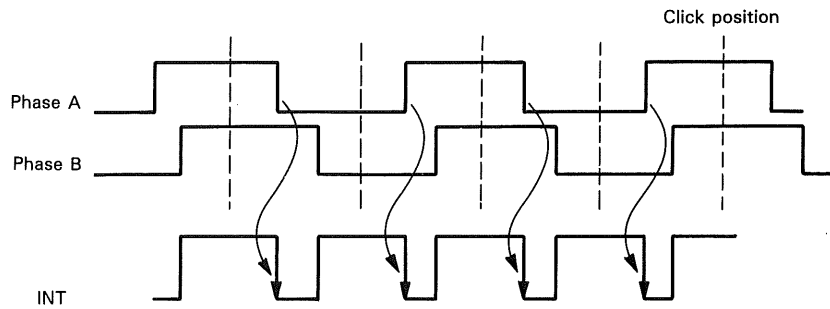

Fig. 2

Figure 2 shows the output waveforms of the rotary encoder, and phases A and B have the output waveforms indicated. In the case of the CH1 VOLTS/DIV rotary encoder, for example, the outputs from phases A and B are input to U29b and U31c respectively. U29 and U31 form a Schmitt circuit, eliminating chattering occurring when the rotary encoder is rotated, and shaping the waveforms to resemble those shown in the above diagram. (This is performed to prevent spurious operation.)

The signal with the waveform shaped is input to U30c, output as the INT signal shown in Figure 2. Q of U22a goes to "L" at the point indicated by the arrow and an interrupt signal is sent to the CPU. When the CPU enters the interrupt state, it immediately evaluates the status of phases A and B, determines the rotation to the right or left by the status of the change, and performs the appropriate processing. (The figure shows rotation to the right.)

U31a and U31b form the Schmitt for the CH2 VOLTS/div rotary encoder, U30d receives the signal after waveform shaping, and U23a receives the INT signal. U31d and U30a form the Schmitt for the CH2 Sweep Time/div rotary encoder, U30b receives the signal after waveform shaping, U22b receives the INT signal.

The DTP adds two analog voltages and is a 5000 count FS. These analog voltages are V-Delay and C-Delay. V-Delay is counted up to 4000 counts with C-Delay as 0 V, and is added by U45b. Following this, V-Delay and C-Delay are decreased one count each until 5000 counts are reached. This is equivalent to doubling the D/A resolution. The added DTP voltage passes through the U46b buffer amp, and is fed to the horizontal unit (X74-1480-01).

The voltage from the endless VRs used for cursor, H-POS1, and H-VARI is received by the U34 analog switch, and the control signal for selecting the endless VR is selected by VX0 to VX2 of U33. The output of the endless VR selected by U34 is input to U35, and compared with the voltage output from D/A convertor U37 by U35. As the U37 D/A convertor is a 12-bit unit and 8 bits are output to the D/A (U33 DA0 to DA7), the upper 4 bits are latched by U36 and the remaining 8 bits are then output. The discrete circuit formed by Q1, Q2, etc., and connected to Pin 17 of U37 is a DC-DC convertor circuit used to supply -11 V to the D/A convertor.

The H-POS1 voltage is supplied to the horizontal unit through the hold circuit.

A random can method (X-Y display) is used for character display, and the U32 character generator is controlled by the character counter of the U33 R/O controller and the dot counter.

One cycle for readout indication is divided into four, and consists of lower characters, upper characters, Δ REF cursor, and Δ cursor.

Character data having a basic configuration of 5×7 dots is input to the U32 character generator. The 3 bits from D00 to D02 are X-axis data, the four bits D03 to D06 are the Y-axis data, and D07 is the character start/end control signal. The digital signal output from U32 is converted to the analog voltages by the U42 D/A convertor for the X-axis signal and the D/A convertor for the Y-axis signal formed by U39 and R58. These signals pass through analog switches U40 and U43, the U44 buffer amp, and are supplied to the final unit (X80-1100-01) as the R/O-X and R/O-Y character signals.

Character dot display on the CRT is controlled by the ROUB, ROB, and ROQ signals output from Pins 86, 87, and 88 of U33.

The ROB signal erases the real waveform display, the real waveform and readout are switched by the ROQ signal, and dot indication on the readout is performed by the ROUB signal.

BLOCK DIAGRAM

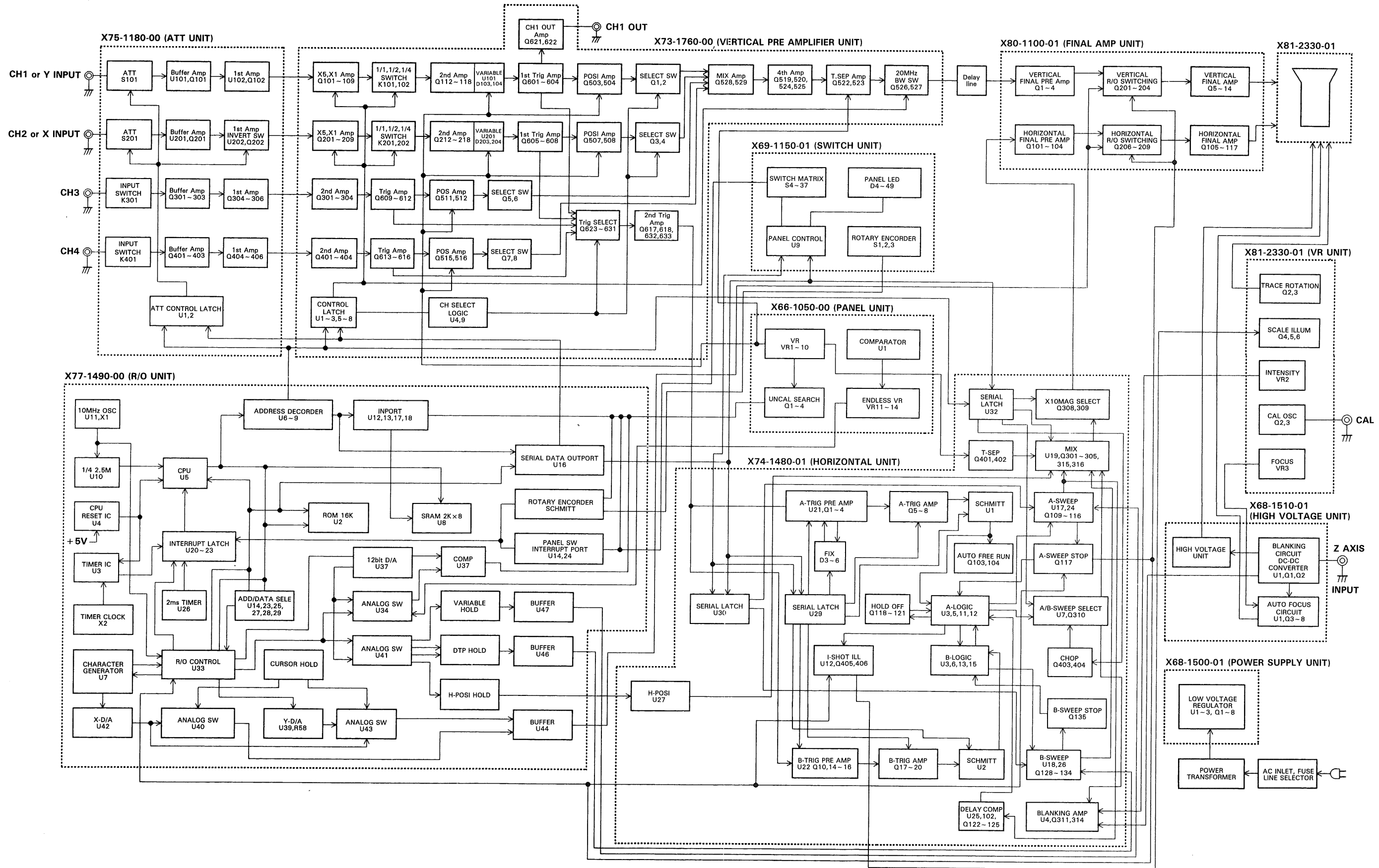

ADJUSTMENT

To obtain the best performance, periodically calibrate the unit. Sometimes, only one mode need be calibrated, while at other times, all modes should be calibrated. When one mode is calibrated, it must be noted that the other modes may be affected. When calibrating all modes, perform the calibration in the specified sequence.

The following calibration required an accurate measuring instrument and an insulated adjusting flat blade screwdriver. If they are not available, contact your dealer. For optimum adjustment, turn the power on and warm up the scope sufficiently (more than 30 minutes) before starting.

Before calibrating the scope, check the power supply voltage.

TEST EQUIPMENT REQUIRED

The following instrument or their equivalent should be used for making adjustment.

Test Equipment	Model	Minimum Specification
Digital Multi-Meter	DL-706 (KENWOOD)	Impedance: More than 10 MΩ, Measuring range: 0.01 V to 199 V
Sine-Wave Generator	651 B (YHP)	Frequency: 10 Hz to 10 MHz, constant voltage over tuning range
Sine-Wave Generator	SG-503 (Tektronix)	Frequency: 50 kHz to 100 MHz, Output impedance: 50 Ω, constant voltage over tuning range
Square-Wave Generator	PG-506 (Tektronix)	Output signal: 1 kHz, Amplitude: 10 mVp-p to 10 Vp-p, Accuracy: within ± 1%, Rise time: 35ns or less 100 kHz, Rise time: 1 ns or less
Q Meter	4343B (YHP)	—
Color Pattern Generator	CG-911A (KENWOOD)	—
Oscilloscope	475A (Tektronix)	Sensitivity: more than 5 mV Frequency response: More than 250 MHz
Time-Marker Generator	TG-501 (Tektronix)	Time mark: 0.5 s to 0.1 μs repetitive waveform
High-Voltage Probe	—	Input Impedance: 1000 MΩ
Termination	—	Impedance: 50 Ω Accuracy: within 3%
Termination	—	3 watts type impedance: 50 Ω
Attenuator	—	- 20 dB attenuation (50 Ω)

Table 1

PREPARATION FOR ADJUSTMENT

Control Settings

The control settings listed below must be used for each adjustment procedure.

Exceptions to these settings will be noted as they occur. After completing an adjustment, return the controls to the following settings.

NAME OF KNOBS	POSITION
INTEN	12 o'clock, A INTEN
READOUT INTEN	Fully counterwise
FOCUS, ASTIG	Optimum position
CH1, CH2, CH3, CH4 POSITION	Mechanical center
◀▶ POSITION/× 10MAG	Mechanical center/push
VARIABLE, H.VARIABLE	CAL
(VOLTS/DIV, SWEEP TIME/DIV)	
AC-GND-DC (CH1 and CH2)	DC (GND at no signal)
VERTICAL MODE	CH1
TRIGGERING COUPLING	AC
TRIGGERING SOURCE	CH1
TRIGGERING LEVEL	Mechanical center
TRIGGERING MODE	AUTO
VOLTS/DIV (CH1 and CH2)	10 mV/DIV
SWEEP TIME/DIV	1 ms/DIV
HORIZONTAL MODE	A
HOLDOFF	NORM

Table 2

ADJUSTMENT

1. POWER SUPPLY AND CRT SECTION ADJUSTMENTS

Item	Adjustment VR (TC)	P.C.B.	Procedure
- 10 V	VR1	X68-1500	Adjust VR1 so that the voltage at pin 8 of the connector P17 is - 10.00 V.
Intensity	VR1	X68-1510	Display the spot on the CRT screen, and adjust VR1 so that the spot disappears when the INTEN knob is set to the 9 o'clock position.
Focus Center	VR2	X68-1510	Push the FOCUS knob in (for the FOCUS operation) and then set it to the mechanical center position. Pull the knob out (for the ASTIG operation), display a spot on the screen, and adjust the ASTIG control and VR2 to minimize the dimension of the spot.
CRT Center	VR513	X73-1760	VERTICAL MODE: CH1, CH2, ADD Make the luminescent line overlap at each ◀ position. Adjust VR513 so that the luminescent line is moved to the center of the CRT screen.
Vertical Center Voltage	VR3	X80-1100	Turn off R/O. In the state of CRT Center Adjustment, adjust VR3 so that the voltage at pin 1 of the connector P14 becomes 34.5 V.
Horizontal Center Voltage	VR102	X80-1100	Engage the CH1 mode. Activate the X-Y operation mode, and set so that the spot moves to the center of the CRT. Adjust VR102 so that the voltage at pin 1 of the connector P15 becomes 67.5 V.
R/O Vertical Gain	VR4	X80-1100	Set the ΔV VR control to "MIN" and "MAX" (◐ ◑) in turns. Adjust VR102 so that the separation between these two settings for the cursor is of 8 divisions of the scale.
R/O Vertical Position	VR201	X80-1100	In the state of the R/O Vertical Gain Adjustment, adjust VR201 to meet the following scale values: 0 division - ◐ 8 divisions - ◑
R/O Horizontal Gain	VR101	X80-1100	Set the ΔT VR control to "MIN" and "MAX" (◐ ◑) in turns. Adjust VR101 so that the separation between these two settings for the cursor is of 10 divisions of the scale.
R/O Horizontal Position	VR202	X80-1100	In the state of R/O Horizontal Gain Adjustment, adjust VR202 to meet the following scale values: 0 division - ◐ 10 divisions - ◑

2. VERTICAL SECTION ADJUSTMENTS

Item	Adjustment VR (TC)	P.C.B.	Procedure
CH2 Balance	VR201	X75-1180	Adjust VR201 so that even when the CH2 INV switch is turned ON/OFF repeatedly, the luminescent lines does not move.
CH2 Position	VR101	X75-1180	Short between pin 1 and pin 3 at P5. Set the vertical mode to "CH1", "CH2", then "ADD". Set it to the scale center by "◀ POSITION". Remove the short-circuiting. Adjust VR101 so that the deviated luminescent line comes to the scale center.
CH1 Step ATT Balance	VR103 VR101	X73-1760	Adjust VR103 so that the position of the luminescent line does not change even when the vertical attenuator is selected between 1 and 2 mV range. Switch the range between 2 and 5 mV ranges, and perform the same adjustment using VR101.

ADJUSTMENT

Item	Adjustment VR (TC)	P.C.B.	Procedure
CH2 Step ATT Balance	VR203 VR201	X73-1760	Adjust in the same way as for CH1.
CH1 Position Center	VR503	X73-1760	CH1 POSITION : Mechanical center position CH1 VOLTS/DIV : 0.1 mV Adjust VR503 so that the trace is located on the center of the screen.
CH2 Position Center	VR506	X73-1760	Adjust in the same way as for CH1.
CH3 Position Center	VR509	X73-1760	Adjust in the same way as for CH1.
CH4 Position Center	VR512	X73-1760	Adjust in the same way as for CH1
CH1 Variable Balance	VR104	X73-1760	Adjust VR104 so that the position of the luminescent line does not change even if the VARIABLE knob is rotated. Vary the settings of the VOLTS/DIV and VARIABLE controls and see if the trace position also moves; if it does, adjust VR103, 101 and 104 again.
CH2 Variable Balance	VR204	X73-1760	Adjust in the same way as for CH1.
CH1 Gain	VR501	X73-1760	CH1 VOLTS/DIV: 10 mV Input a square wave signal having an amplitude of 50 mV, and adjust VR501 so that the CRT amplitude becomes 5 div.
CH1 1 mV Range Gain	VR102	X73-1760	CH1 VOLTS/DIV: 1 mV Input a square wave signal having an amplitude of 5 mV, and adjust VR102 so that the CRT amplitude becomes 5 div.
CH2 Gain	VR504	X73-1760	Adjust in the same way as for CH1.
CH2 1 mV Range Gain	VR202	X73-1760	Adjust in the same way as for CH1.
CH3 Gain	VR507	X73-1760	CH3 VOLTS/DIV: 0.1 mV Input a square wave signal having an amplitude of 50 mV, and adjust VR507 so that the CRT amplitude becomes 5 div.
CH4 Gain	VR501	X73-1760	Adjust in the same way as for CH1.
CH1 Waveform Shaping	TC105 TC103	X75-1180	AC-GND-DC: DC Apply 1 kHz square wave to CH1 input (with the amplitude extending over 4 to 6 div). Set CH1 VOLTS/DIV to 0.1 V range (and 1 V range), and adjust TC105 (and TC103) so that the waveform becomes flat in both ranges.
CH1 Input Capacity	TC104 TC102	X75-1180	AC-GND-DC : DC CH1 VOLTS/DIV : 10 mV Connect the capacity meter to the CH1 input, and measure the input capacity in the 10 mV range. Adjust TC104 and TC102, alternately, so that the input capacity in the 0.1 V and the 1 V ranges equals the same capacity as in the 10 mV range.
CH2 Waveform Shaping	TC205 TC203	X75-1180	Adjust in the same way as for CH1.
CH2 Input Capacity	TC204 TC202	X75-1180	Adjust in the same way as for CH1.
CH3 Waveform Shaping	TC302	X75-1180	Apply 1 kHz square wave to CH1 input (with the amplitude extending over 4 to 6 div). Set CH3 volts/div to 0.5 V range, and adjust TC302 so that the waveform becomes flat.

ADJUSTMENT

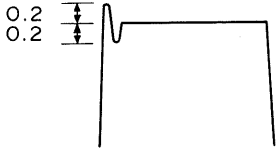
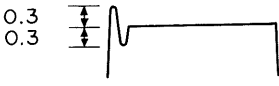
Item	Adjustment VR (TC)	P.C.B.	Procedure
CH3 Input Capacity	TC301	X75-1180	Connect the capacity meter to the CH3 input, and measure the input capacity in the 0.1 V range. Adjust TC301, so that the input capacity in the 0.5 V range equals the same capacity as in the 0.1 V range.
CH4 Waveform Shaping	TC402	X75-1180	Adjust in the same way for CH3.
CH4 Input Capacity	TC401	X75-1180	Adjust in the same way for CH3.
CH1 Square Wave Characteristics	TC101 TC501 VR502	X73-1760	CH1, 2 VOLTS : 10 mV CH1, 2 AC-GND-DC : DC SWEEP TIME/DIV : 1 μ s $\times 10$ MAG : ON <ul style="list-style-type: none"> • Input a 1 MHz square wave signal into CH1 (with a CRT amplitude of 6 div.). * Adjust TC101 so that the overshoot is maximized. * Set a TC or the VR to an adjustment angle as shown in Figure 1 or 2 to bring about ± 0.2 division of the scale. • Input the 1 MHz square wave signal into CH2 (with the CRT amplitude of 6 div.). * Adjust TC201 so that the overshoot is maximized. * Set a TC or the VR to an adjustment angle as shown in Figure 1 to bring about ± 0.2 division of the scale.
	TC1 TC2 VR1	X80-1100	
	TC101	X75-1180	
CH2 Square Wave Characteristics	TC201 TC502 VR505	X73-1760	
	TC201	X75-1180	
CH3 Square Wave Characteristics	TC503 VR508	X73-1760	CH3, 4 : 0.1 V/div. * Set a TC or VR to an adjustment angle as shown in Figure 1 to bring about ± 0.3 division of the scale. 
CH4 Square Wave Characteristics	TC504 VR511	X73-1760	

ADJUSTMENT

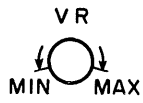

"MIN": Rotated fully counterclockwise
"MAX": Rotated fully clockwise



TC (without lock mechanism)
Counterclockwise rotation: Unclear waveform \square (Under)
Clockwise rotation: Clear waveform h (over)

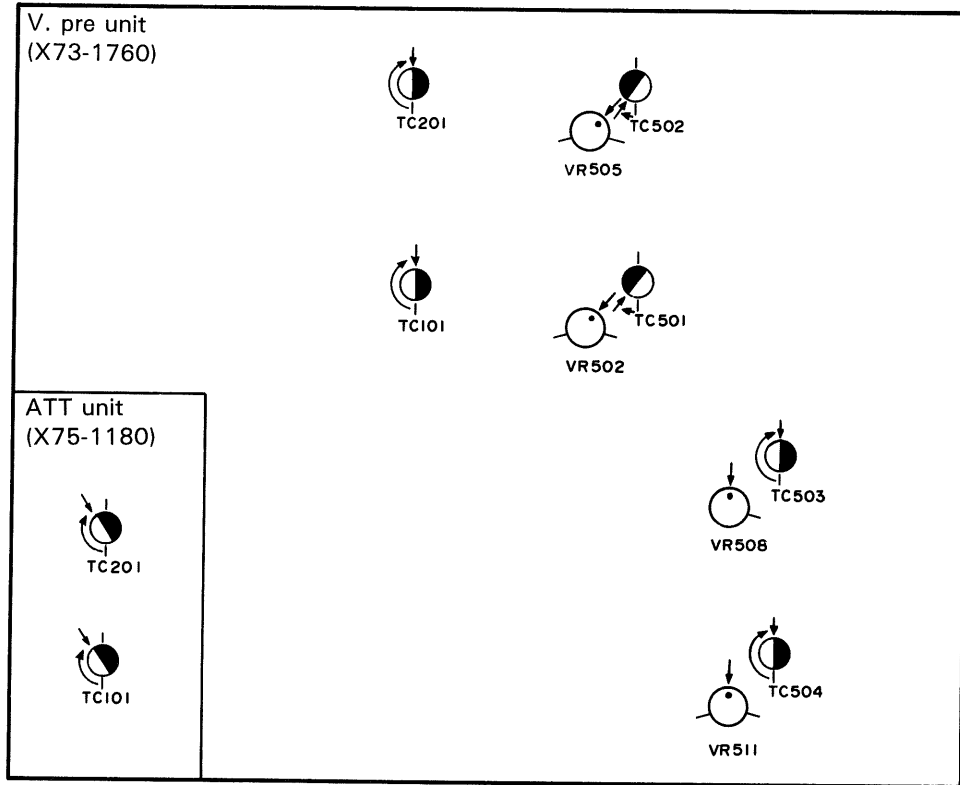

Fig. 1

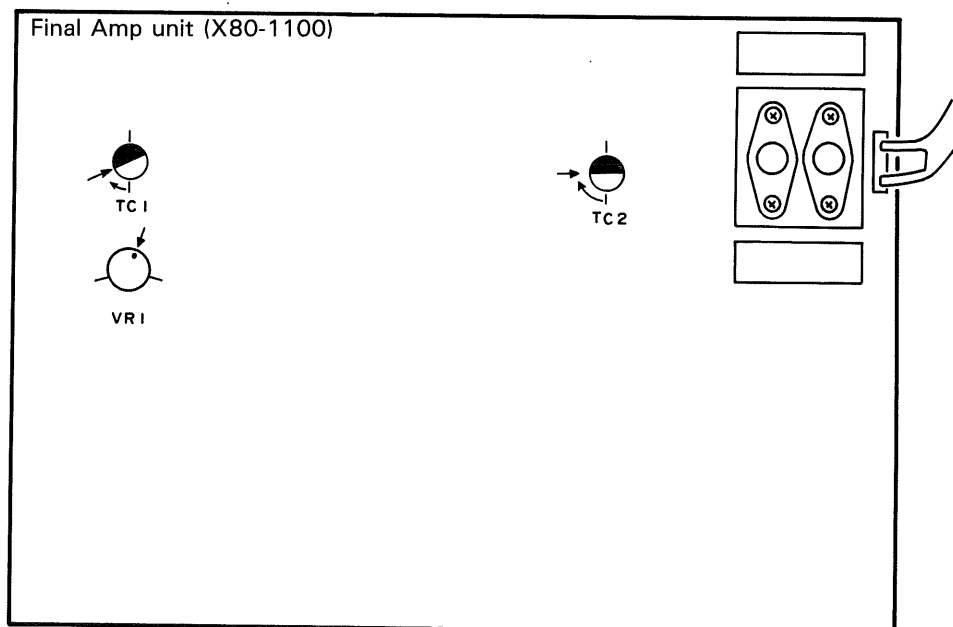

Fig. 2

ADJUSTMENT

3. TRIGGER SECTION ADJUSTMENTS

Item	Adjustment VR (TC)	P.C.B.	Procedure
FIX Level Center	VR1	X74-1480	TRIGGERING MODE : FIX SOURCE : CH1 COUPLING : AC CH1 VOLTS/DIV : 10 mV Input a 1 kHz sine wave into CH1, and adjust the oscillator so that the CRT amplitude becomes 6 div. Adjust VR1 so that start point of the luminescent line is at the center of the CRT (vertical direction).
A TRIG. DC Coupling	VR601(CH1) VR602(CH2) VR603(CH3) VR604(CH4)	X73-1760	After adjusting the trigger level center, set the TRIGGERING COUPLING to the DC position. Adjust VR601 so that the start point of the luminescent line is at the same position as in the AC mode.
B TRIG. Level Center	VR4	X74-1480	TRIGGERING MODE : AUTO SOURCE : CH2 COUPLING : AC LEVEL : Mechanical center CH2 VOLTS/DIV : 10 mV Input a 1 kHz sine wave to CH2, and adjust the oscillator so that the CRT amplitude becomes 6 div. Adjust VR4 so that start point of the luminescent line is at the center of the CRT (vertical direction).
B TRIG. DC coupling	VR3	X74-1480	Set the TRIGGERING COUPLING to the DC position. Adjust VR3 so that the start point of the luminescent line is at the same position as in the AC mode.

4. HORIZONTAL SECTION ADJUSTMENTS

Item	Adjustment VR (TC)	P.C.B.	Procedure
A SWEEP Time	VR301	X74-1480	SWEEP TIME/DIV: 1 ms Input a 1 ms marker signal into CH1. Adjust VR301 so that the peak of the marker signal matches the CRT scale divided in 1 div.
	VR103	X74-1480	SWEEP TIME/DIV: 1 ms ~ 5 ms Adjust VR103 in the same way as for 1 ms adjustment.
	VR307	X74-1480	SWEEP TIME/DIV: 1 ms Input a 1 ms marker signal into CH1, and match the peak of the marker signal with the CRT scale divided in 1 div. Set to the X10 MAG status, and adjust VR307 so that the interval between peaks becomes 10 div.
	VR103	X80-1100	SWEEP TIME/DIV: 0.2 μ s Input a 0.2 μ s marker signal into CH1. Set to the X10 MAG status, and adjust the horizontal POSITION so that the peak of the waveform is at the vertical scale line at the center of the CRT. Release the X10 MAG mode and adjust VR103 so that the peak of the waveform matches the vertical scale line at the center of the CRT.

ADJUSTMENT

Item	Adjustment VR (TC)	P.C.B.	Procedure
A SWEEP Time	TC101	X74-1480	SWEEP TIME/DIV: 2 μ s Adjust TC101 in the same way as for 1 ms adjustment.
	TC302		SWEEP TIME/DIV: 20 ns Adjust TC302 in the same way as for 1 ms adjustment.
	TC103	X80-1100	SWEEP TIME/DIV: 50 ns X10 MAG : ON Input a 5 ns marker signal into CH1. Adjust TC103 so that the peak of the marker signal matches the CRT scale divided in 1 div.
	TC101	X80-1100	SWEEP TIME/DIV: 20 ns X10 MAG : ON Input a 4 ns sine wave signal into CH1. Adjust TC101 so that the peak of the marker signal matches the CRT scale divided in 2 div. Repeat this adjustment for 20 ns, 5 ns, then 2 ns to obtain optimum point.
B SWEEP Time	VR302	X74-1480	SWEEP TIME/DIV: 1 ms Input a 1 ms marker signal into CH1. Adjust VR302 so that the peak of the marker signal matches the CRT scale divided in 1 div.
	VR104	X74-1480	SWEEP TIME/DIV: 1 ms ~ 5 ms Input a 1 ms ~ 5 ms signal into CH1, and adjust in the same way as for 1 ms
	TC102	X74-1480	SWEEP TIME/DIV: 2 μ s Input a 2 μ s marker signal into CH1, and adjust in the same way as for 1 ms adjustment.
	TC303	X74-1480	SWEEP TIME/DIV: 20 ns Input a 20 ns marker signal into CH1, and adjust in the same way as for 1 ms adjustment.
A Sweep Position	VR304	X74-1480	HORIZ. MODE : A SOURCE : VERT VERTICAL MODE : CH1 A SWEEP TIME/DIV : 0.5 ms TRIG. MODE : AUTO Apply a 0.5 ms marker signal to CH1 to display a waveform to the center of the CRT screen. Rotate the ◀► POSITION control to maximum clockwise. Measure the deviation between the starting point of the trace and the center of the graticule line. Next, rotate the ◀► POSITION control to maximum counterclockwise and measure the distance between the 12th peak of the waveform and the center of the graticule line. Adjust VR304 so that these deviations will have the same width.
B Sweep Position	VR305	X74-1480	HORIZ. MODE : ALT SLOPE : + A, B INTEN : Fully counterwise Operate ◀ TRACE SEP control to separate the A sweep and B sweep. Set the A VARIABLE to CAL. Adjust VR305 to align the starting point of B sweep with that of A sweep in the horizontal position.

ADJUSTMENT

Item	Adjustment VR (TC)	P.C.B.	Procedure
X Gain	VR303	X74-1480	CH2 VOLTS/DIV : 10 mV TRIGGERING MODE : X-Y Input the square wave signal having an amplitude of 50 mV into CH2, and adjust VR303 so that the CRT amplitude in the horizontal direction becomes 5 div.
X Position	VR306	X74-1480	VERTICAL MODE : CH2 CH2 AC-GND-DC : GND Set the scope controls to display a trace to the graticule center. Adjust VR306 to position to trace to horizontal graticule when switched the HORIZ, MODE switch to X-Y position. Clockwise rotation of channel 2 position control should move up to 5 divisions upward and counterclockwise rotation should move up to 5 divisions downward.
Delay time	VR101 VR102	X74-1480	HORIZ. MODE : ALT CH1 AC-GND-DC : GND A SWEEP TIME/DIV : 1 ms B SWEEP TIME/DIV : 0.2 μ s Rotate the DELAY POSITION control to 0.20 position and set the scope controls to coincide A trace with the left end of the graticule scale, using the horizontal position control. Adjust VR101 to position B trace (intensified portion) to 0.2 div position. Adjust VR102 to position B trace to 10 div. position (right end of the graticule scale) when rotated the DELAY POSITION control to 10.00 position.
CAL Voltage	VR5 VR6	X81-2330	Apply a CAL signal to channel 1 input. Adjust VR5 so that one period becomes 0.1 ms (10 div). Adjust VR6 so that the amplitude becomes 0.2 V (5 div.)

ADJUSTMENT

POWER SUPPLY UNIT (X68-1500-00)

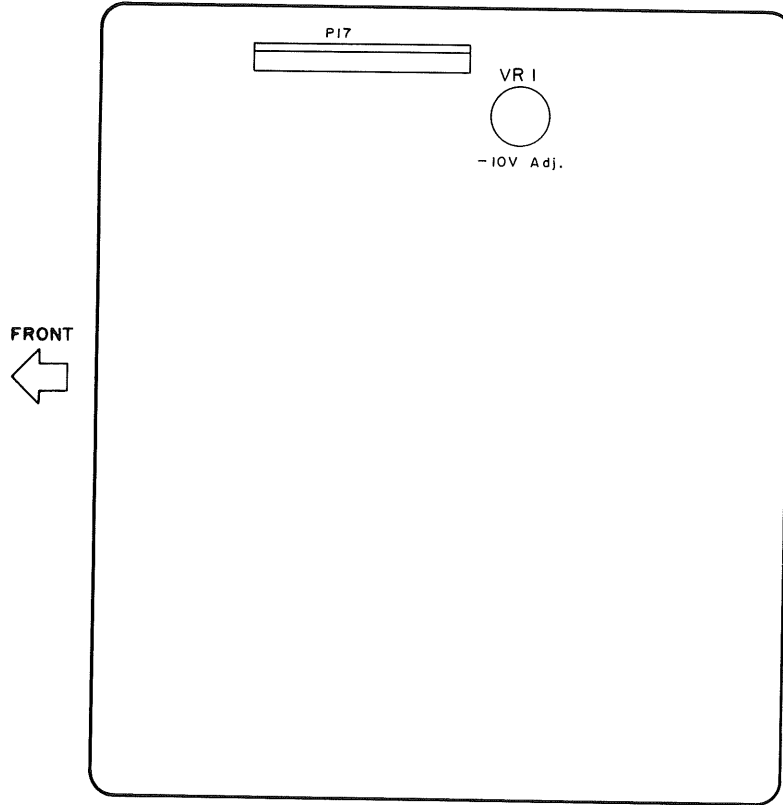

ADJUSTMENT

HIGH VOLTAGE UNIT (X68-1510-01)

FRONT



Pattern side

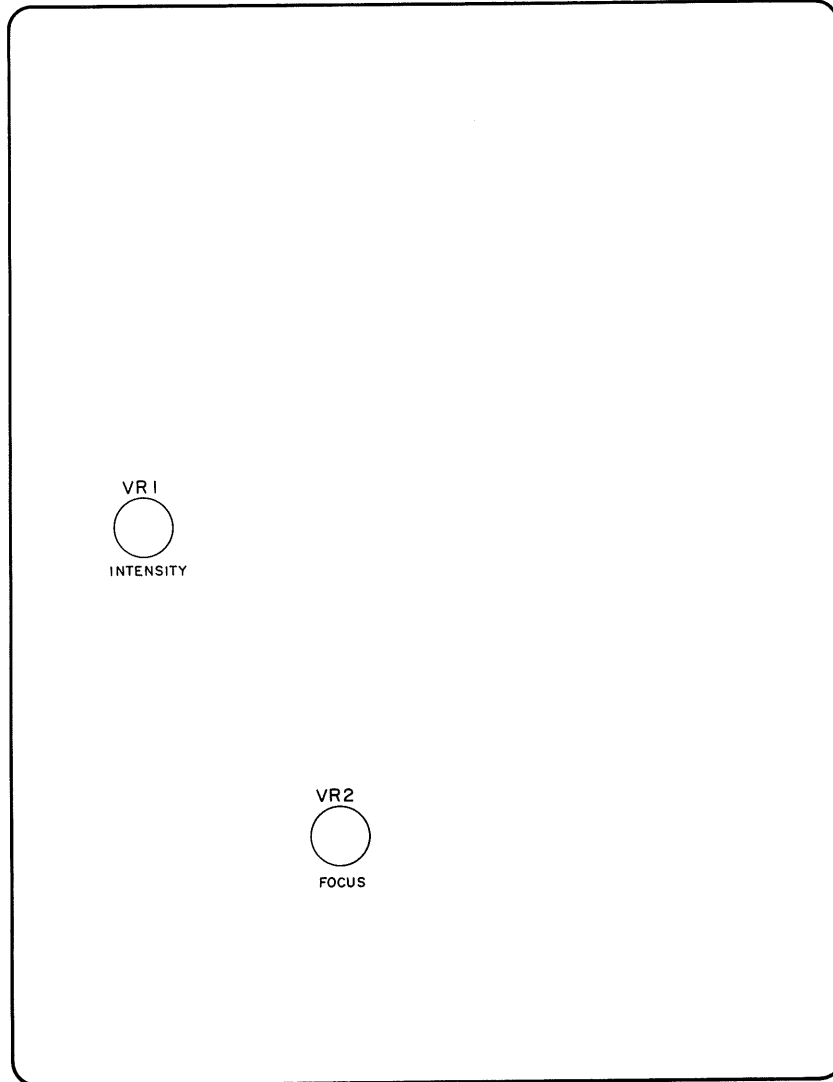

ADJUSTMENT

VERTICAL PRE AMPLIFIER UNIT (X73-1760-00)

FRONT

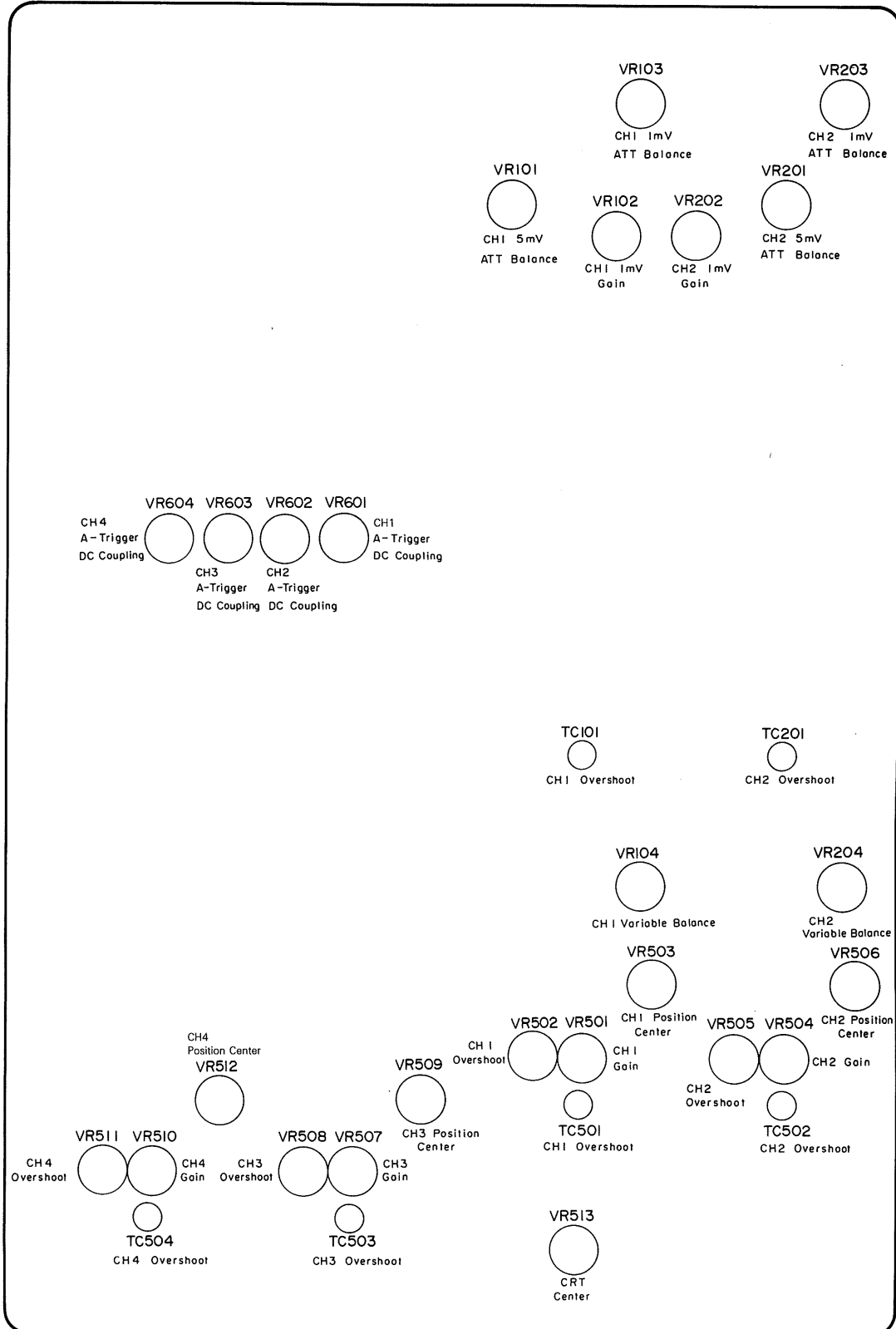

ADJUSTMENT

HORIZONTAL UNIT (X74-1480-01)

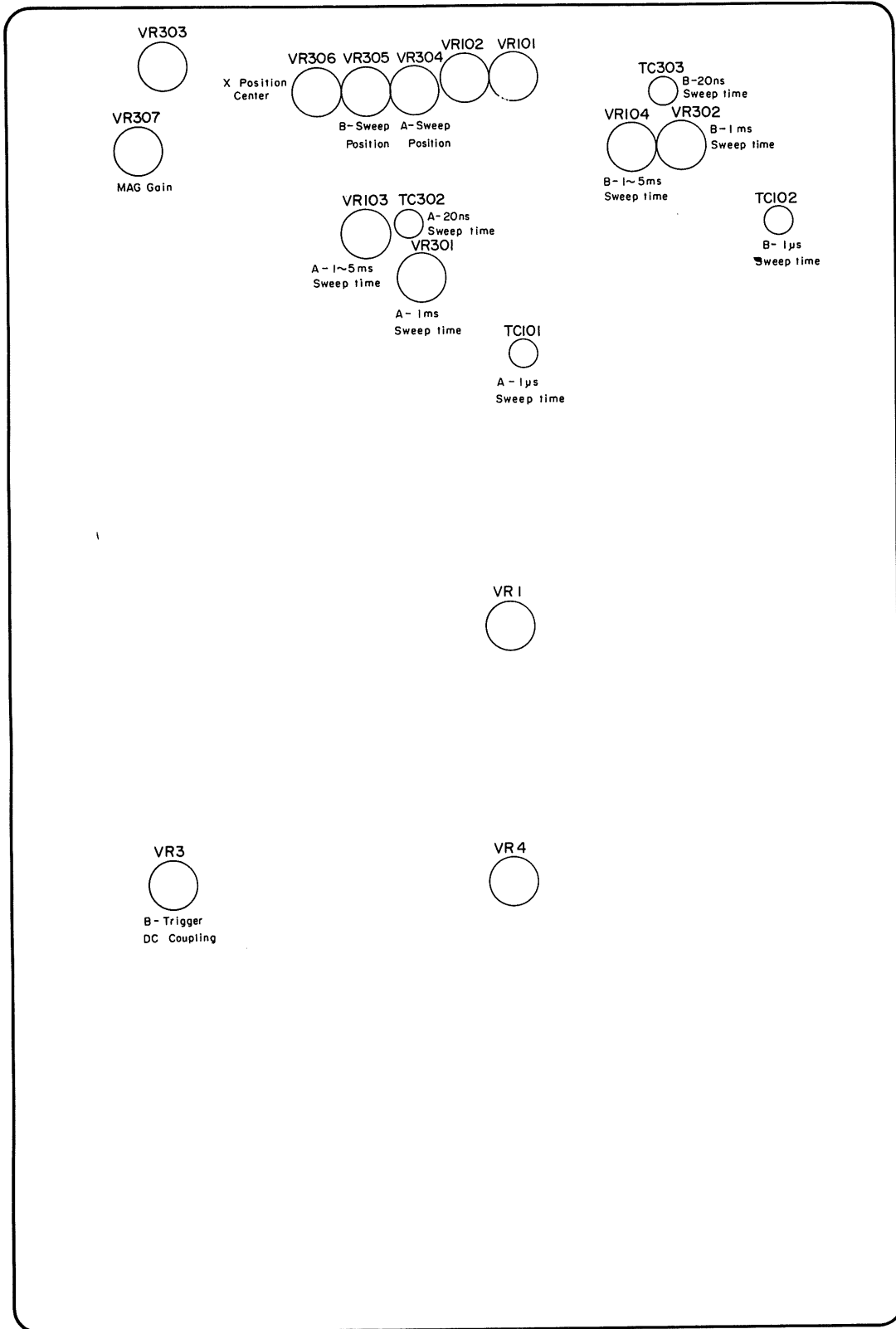

FRONT

ADJUSTMENT

ATT UNIT (X75-1180-00)

FRONT

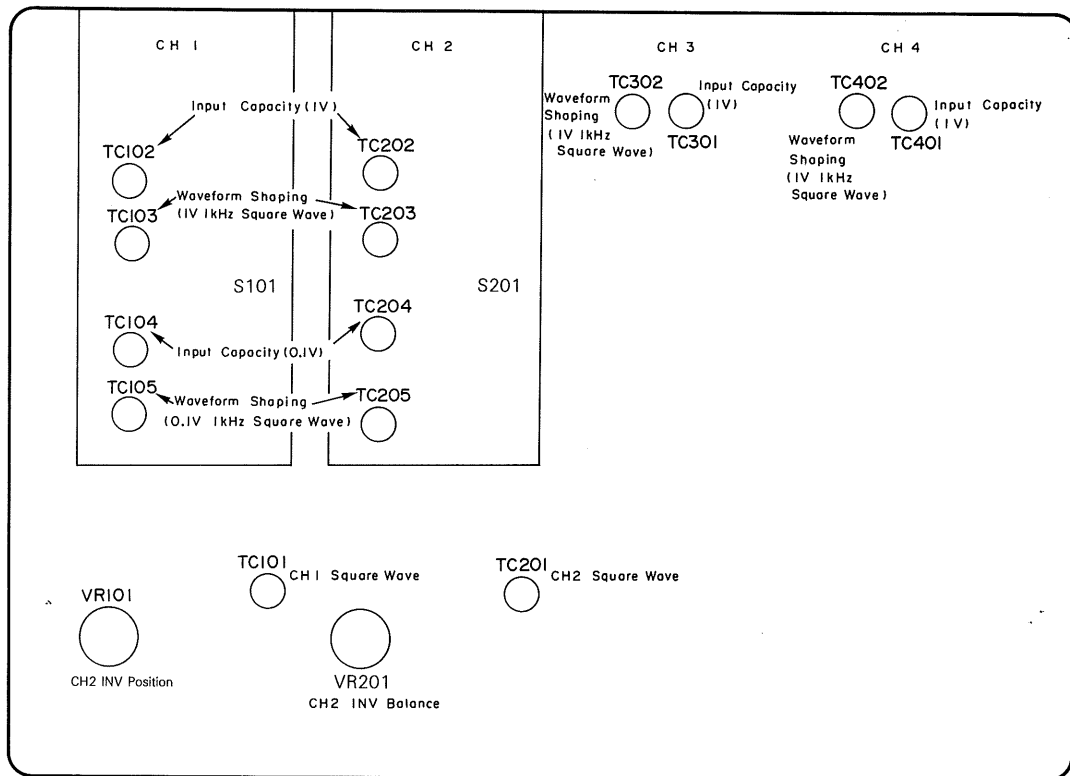

VOLUME UNIT (X81-2330-01)

FRONT

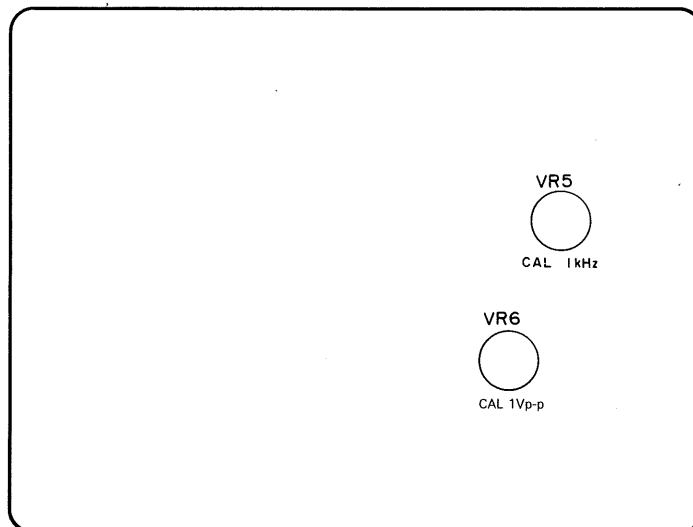

ADJUSTMENT

FINAL AMP UNIT (X80-1100-01)

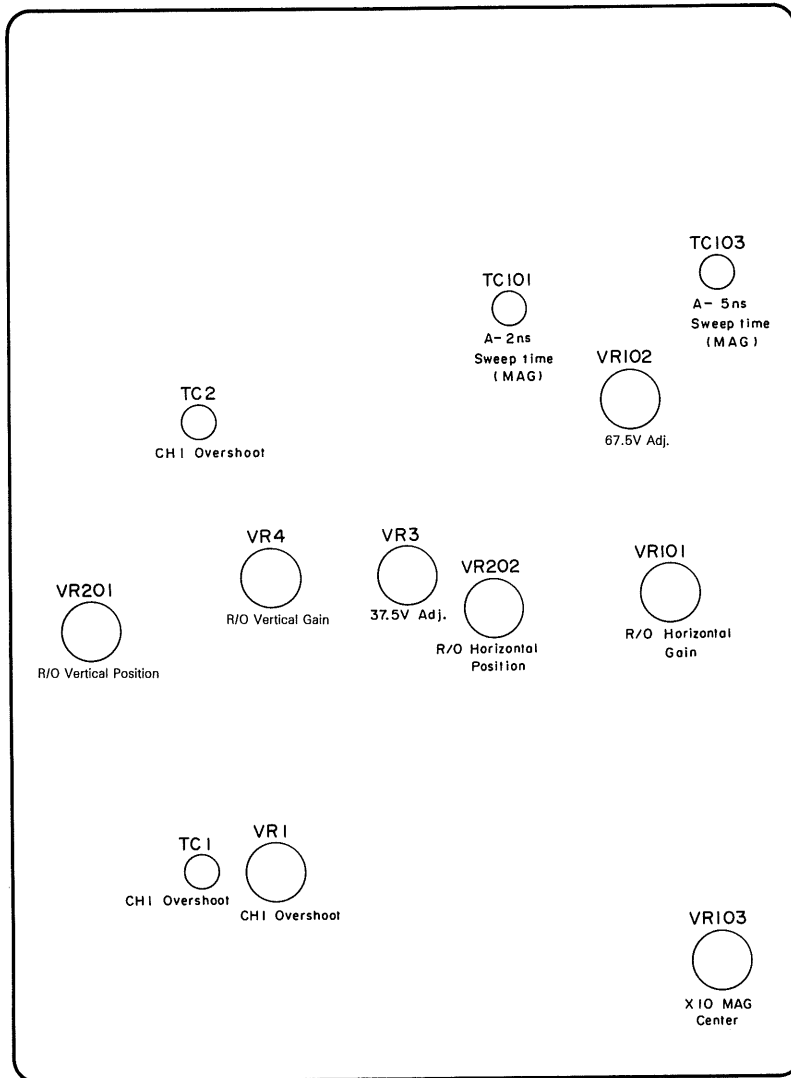

↓
FRONT

TROUBLESHOOTING

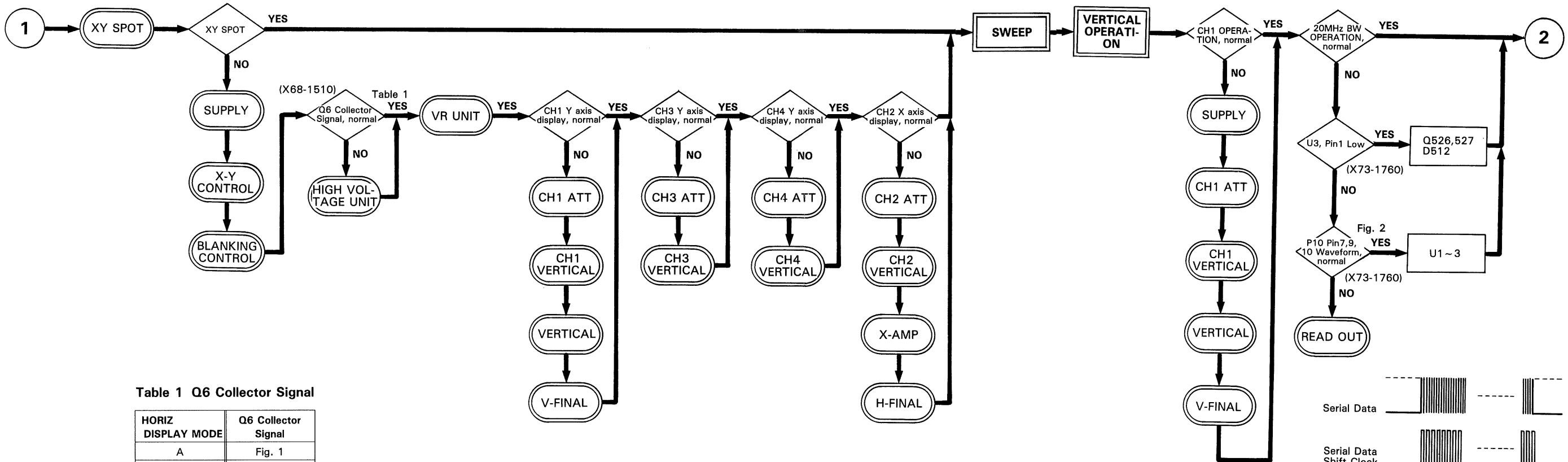
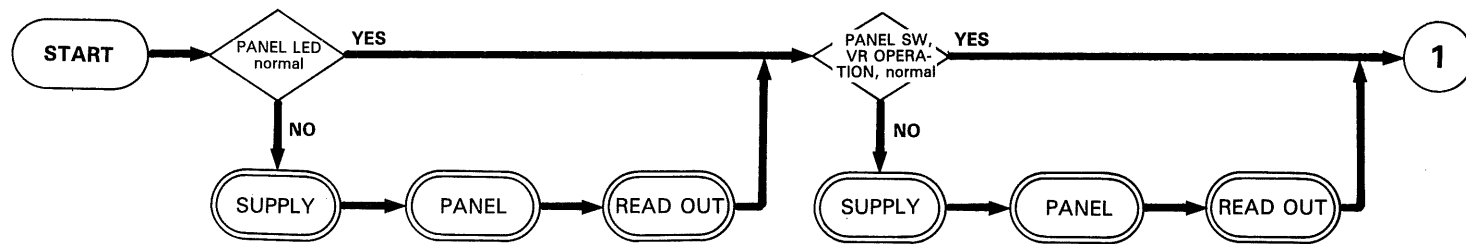

Table 1 Q6 Collector Signal

HORIZ DISPLAY MODE	Q6 Collector Signal
A	Fig. 1
A INT B AFT. D	Fig. 1
ALT AFT. D	Fig. 1
B AFT. D	Fig. 1
X-Y	30 ~ 60V

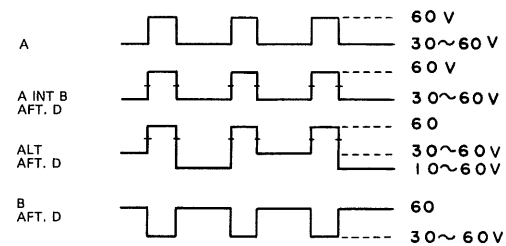

Fig. 1 Q6 Collector Signal

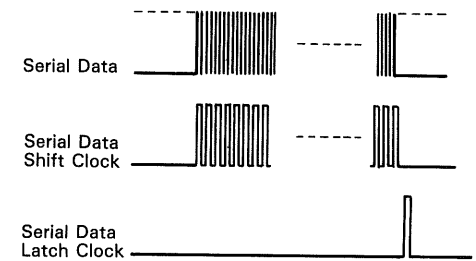
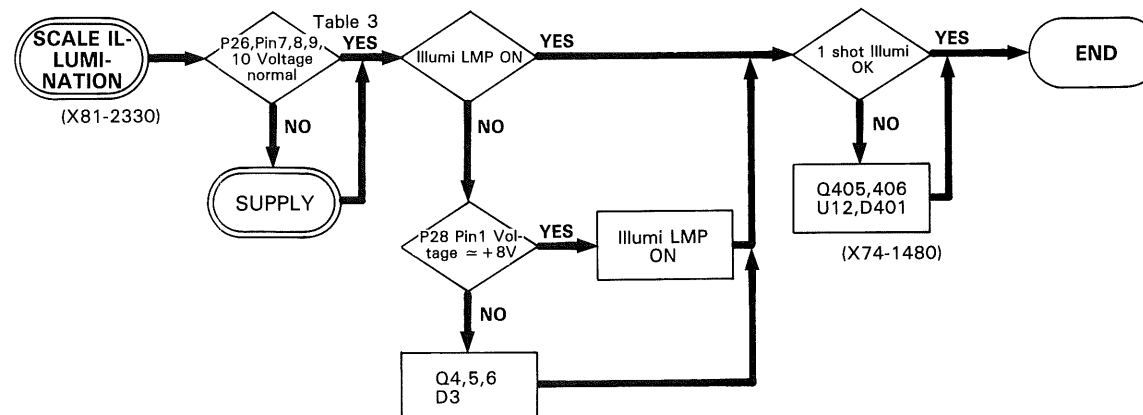
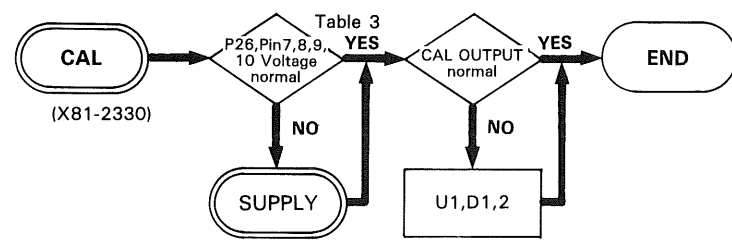
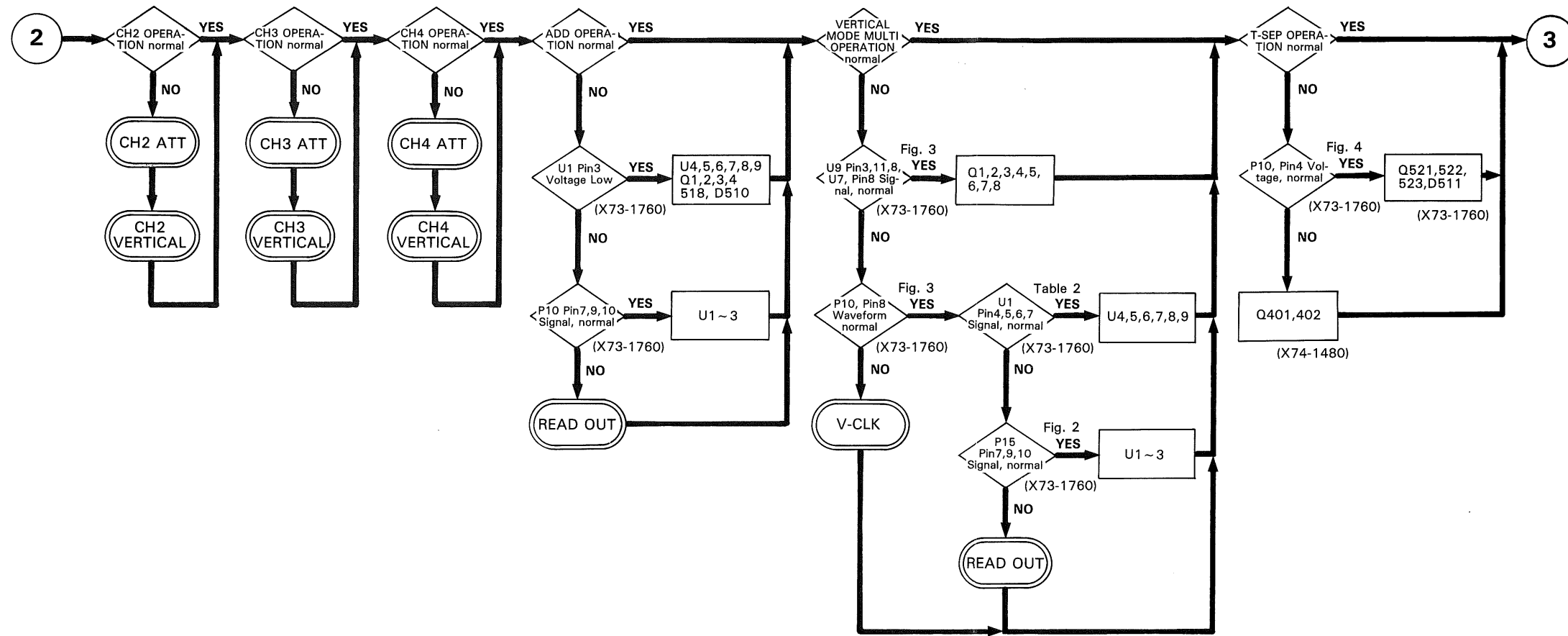

Fig. 2 Serial transmit timing chart

	Panel SW SCAN	Panel LED Control	ATT UNIT Control	V UNIT Control	H UNIT Control
Serial Data	P1 Pin 4 (SD)	P1 Pin 1 (LD)	P4 Pin 9 (AD)	U16 Pin 16 (VD)	U16 Pin 19 (HD)
Serial Data Shift Clock	P1 Pin 5 (SSC)	P1 Pin 2 (LSC)	P4 Pin 8 (ASC)	U9 Pin 14 (VSC)	U9 Pin 10 (HSC)
Serial Data Latch Clock	P1 Pin 6 (SLC)	P1 Pin 3 (LLC)	P4 Pin 7 (ALC)	U8 Pin 11 (VLC)	U8 Pin 7 (HLC)

TROUBLESHOOTING



TROUBLESHOOTING

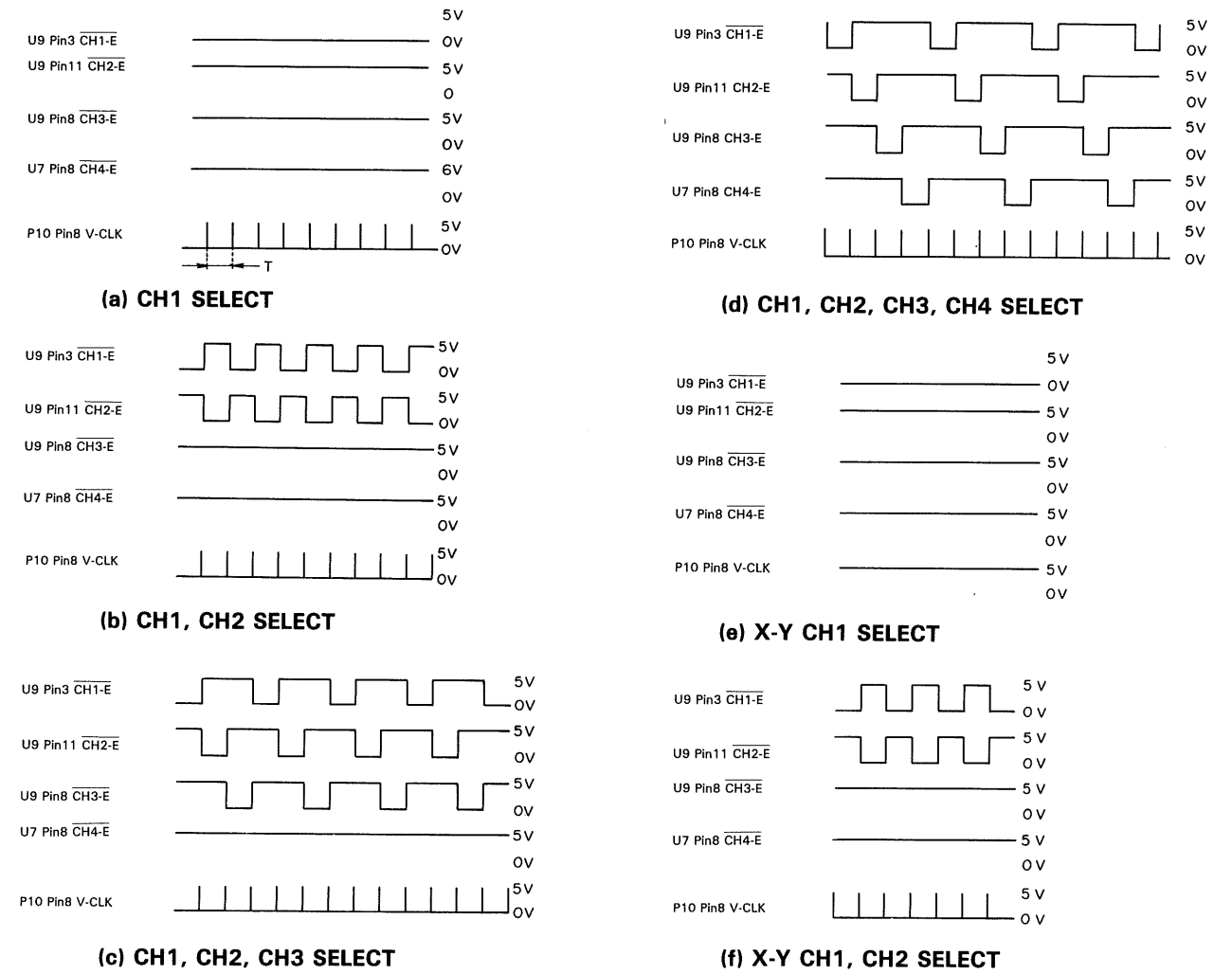
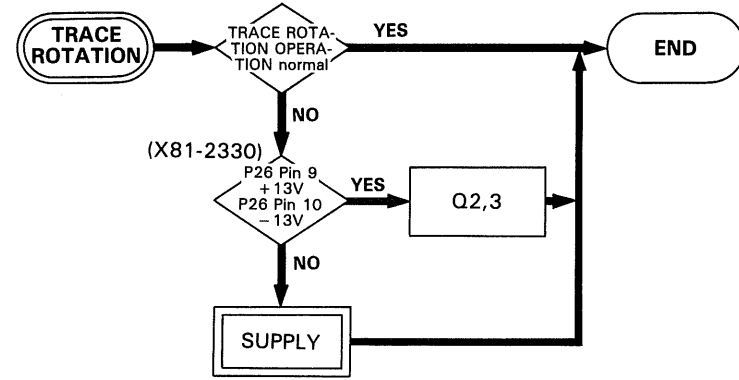

Fig. 3 VERTICAL CH SELECT WAVEFORM

T: H-MODE A, A INT B, B, X-Y
42 μ s: 24kHz

T: H-MODE ALT
84 μ s: 12kHz

Table 2 U1, CH SELECT Voltage

CH SELECT	U1				
	Pin3	Pin4	Pin5	Pin6	Pin7
CH1					L
CH2				L	
CH3			L		
CH4		L			
ADD	LOW				



(a) FULLY CW



(b) FULLY CCW

Fig. 4 P10, Pin4 Waveform

Table 3 Voltage

P26 Pin No.	Voltage [V]
7	+10
8	-10
9	+13
10	-13

TROUBLESHOOTING

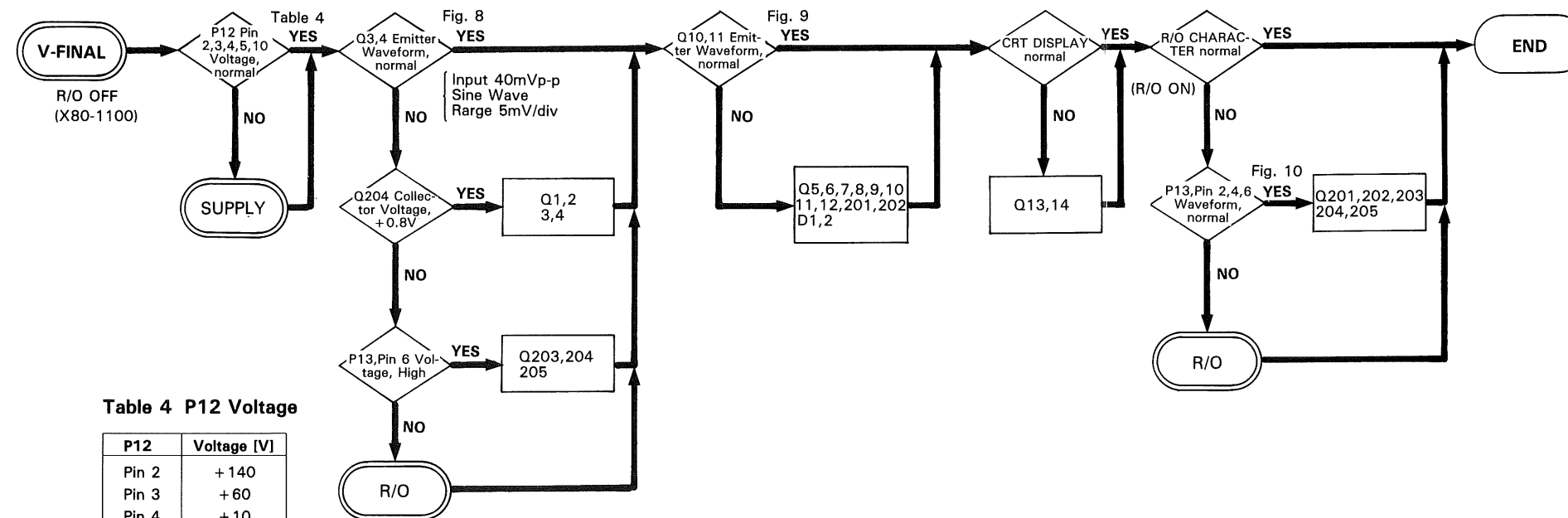
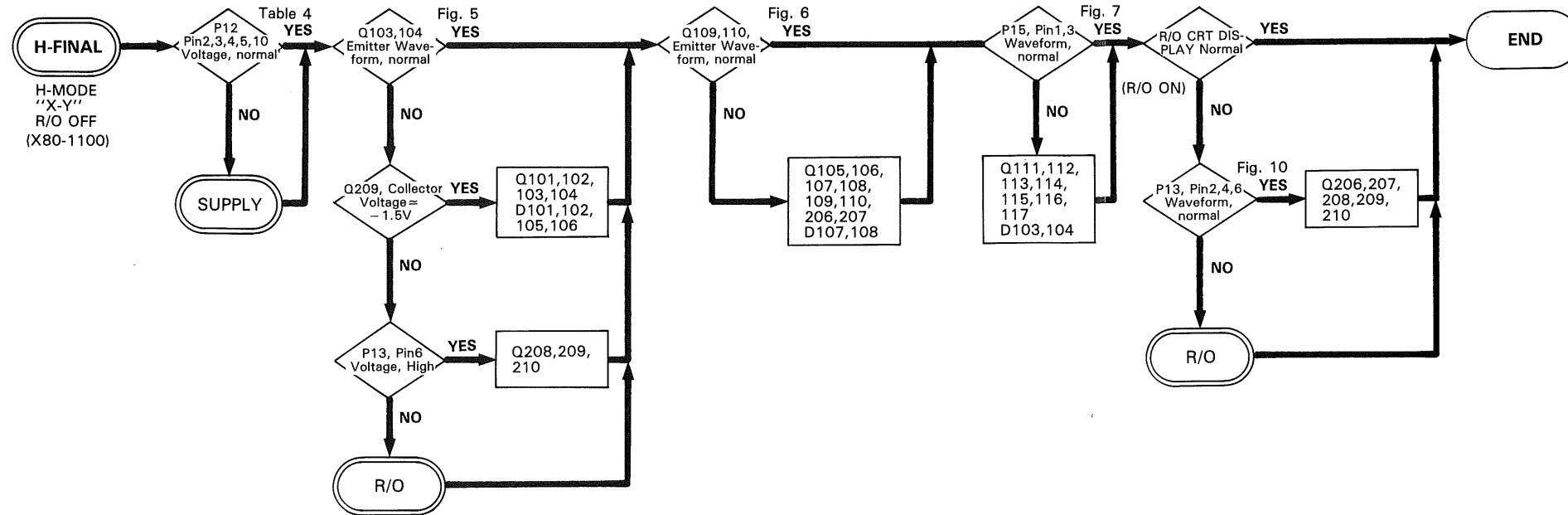

Table 4 P12 Voltage

P12	Voltage [V]
Pin 2	+140
Pin 3	+60
Pin 4	+10
Pin 5	-10
Pin10	+15

TROUBLESHOOTING

H-MODE "X-Y"
 CH2 Input: 40mVp-p 1kHz Sine Wave
 Volts/div: 5mV/div

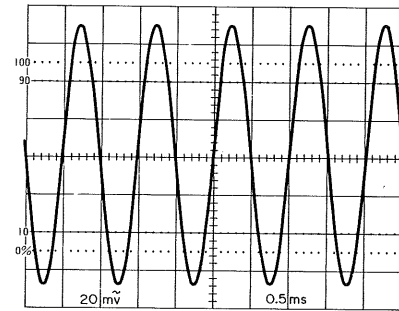

Fig. 5 DC -0.3V

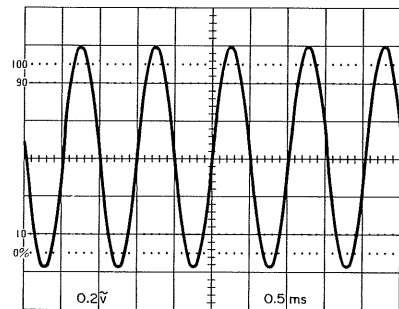

Fig. 6 DC -4V

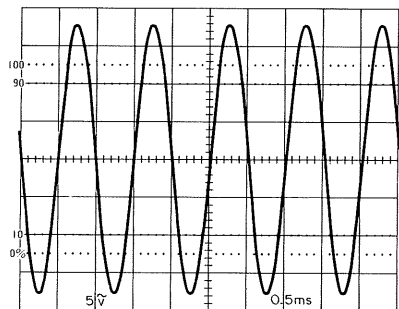
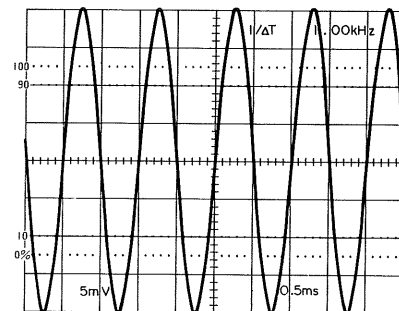

Fig. 7 DC +70V

Input: 40mVp-p, 1 kHz
 Sine Wave
 Volts/div: 5mV/div



CRT

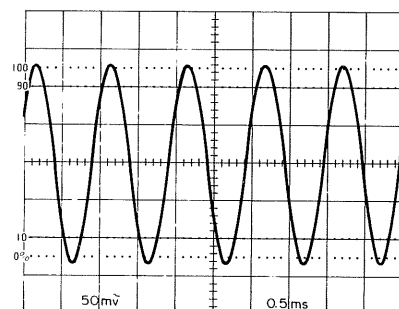

Fig. 8 DC +2.6V

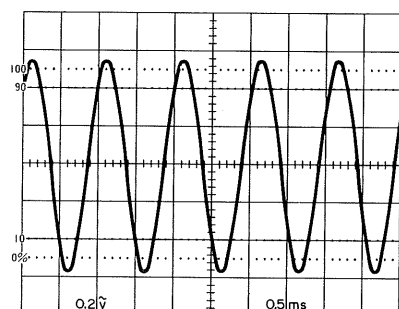
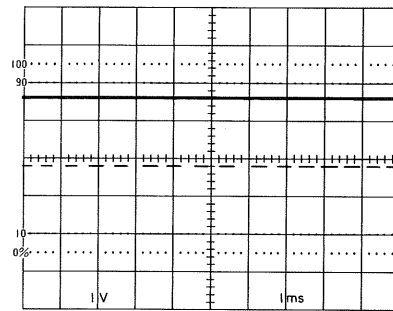
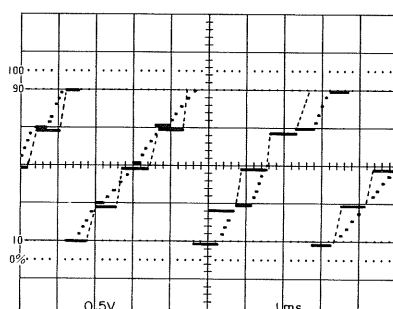

Fig. 9 DC +3.7V



Pin 6



Pin 4

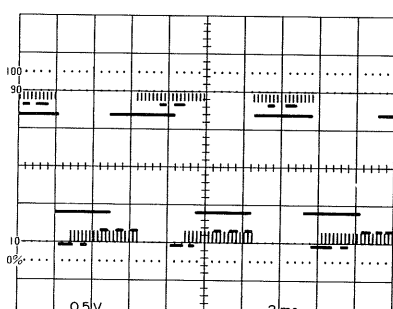

Pin 2

Fig. 10 P13. R/O Signal (R/O ON)

TROUBLESHOOTING

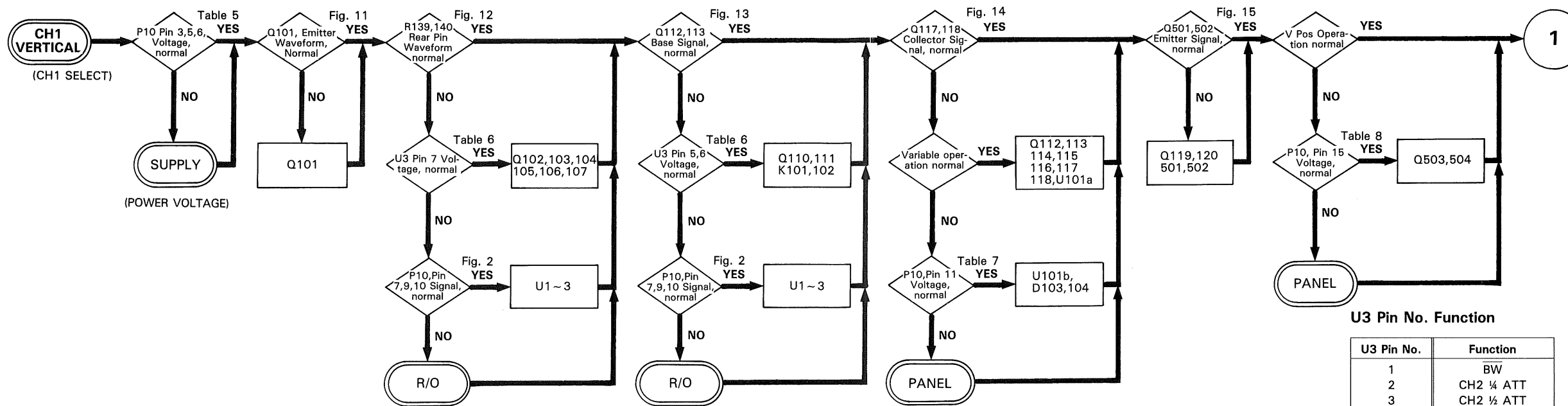

U3 Pin No. Function

U3 Pin No.	Function
1	BW
2	CH2 ¼ ATT
3	CH2 ½ ATT
4	CH2 x 5 Amp
5	CH1 ¼ ATT
6	CH1 ½ ATT
7	CH1 x 5 Amp
15	

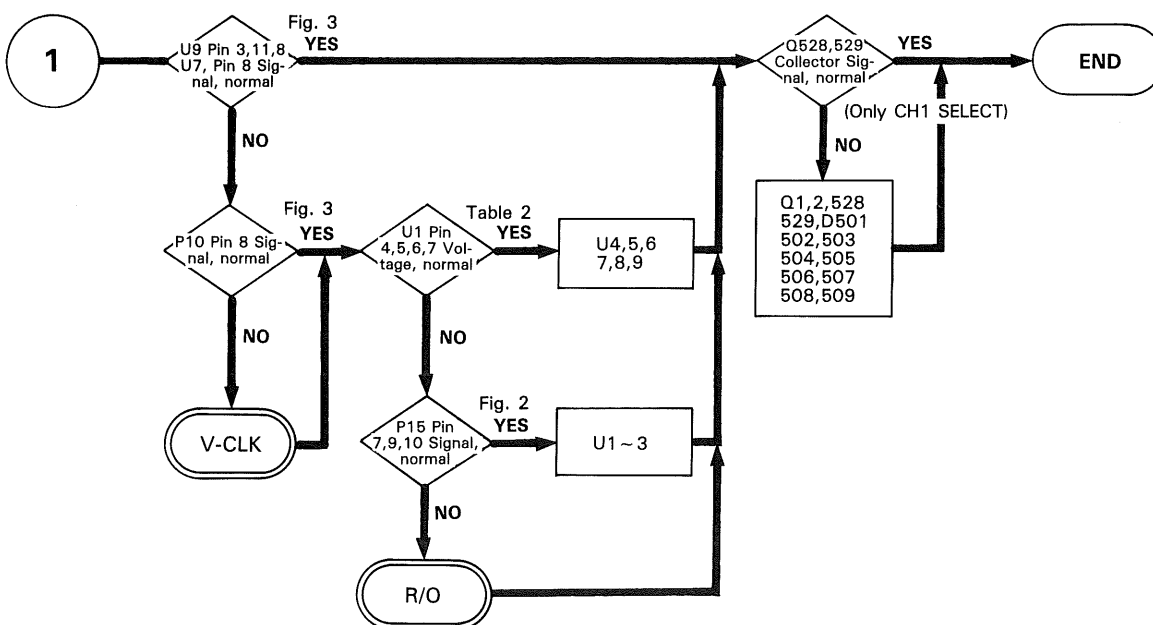

Table 5 Vpre Power Voltage

P10	Voltage [V]
Pin3	+ 10
Pin5	+ 5
Pin6	- 10

Table 6 U3 Pin Voltage

Volts/div	CH2			CH1		
	Pin2	Pin3	Pin4	Pin5	Pin6	Pin7
1 mV		H			H	H
2		H	H		H	H
5		H	H		H	H
10		H	H		H	H
20	H	H	H	H	H	H
50		H	H		H	H
0.1 V		H	H		H	H
0.2	H	H	H	H	H	H
0.5		H	H		H	H
1.0		H	H		H	H
2.0	H	H	H	H	H	H
5.0		H	H		H	H

Table 7 P10 CAL ~ UNCAL

P10	CAL ~ UNCAL
Pin11	0 ~ +10V
Pin12	0 ~ +10V

Table 8 P10 POS VR

P10	Pos VR Fully CW ~ Fully CCW
Pin15	-10V ~ +10V
Pin16	-10V ~ +10V
Pin13	-10V ~ +10V
Pin14	-10V ~ +10V

TROUBLESHOOTING

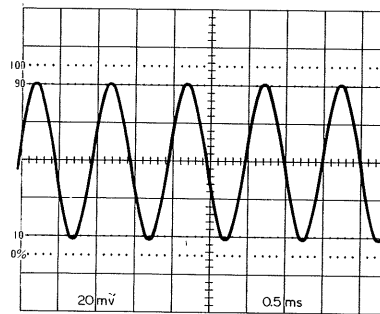
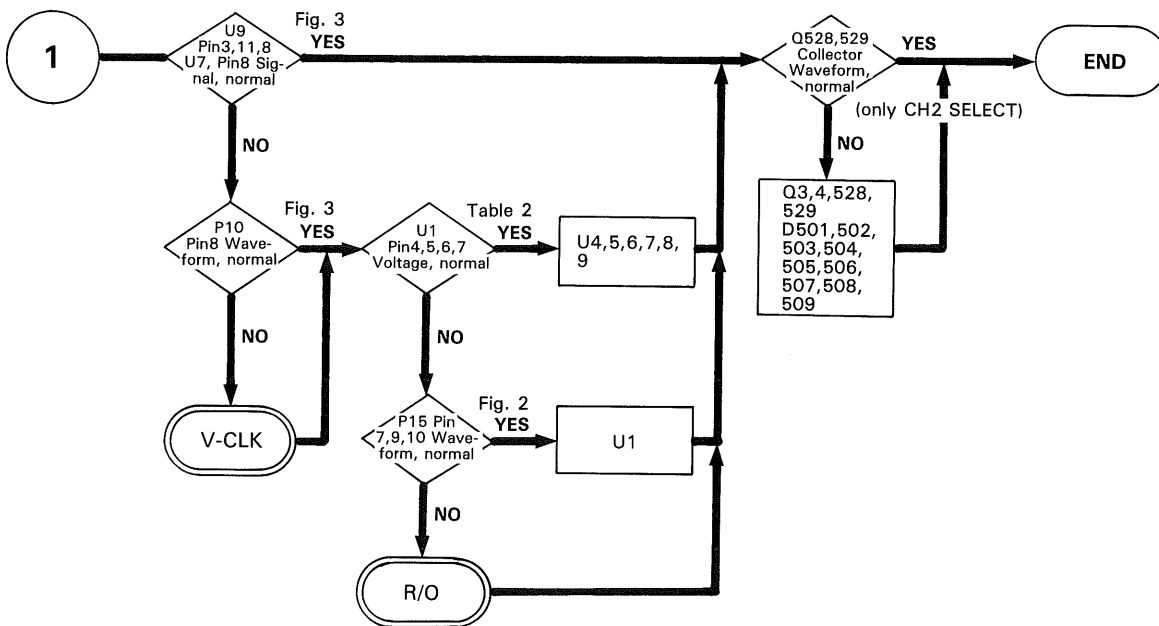
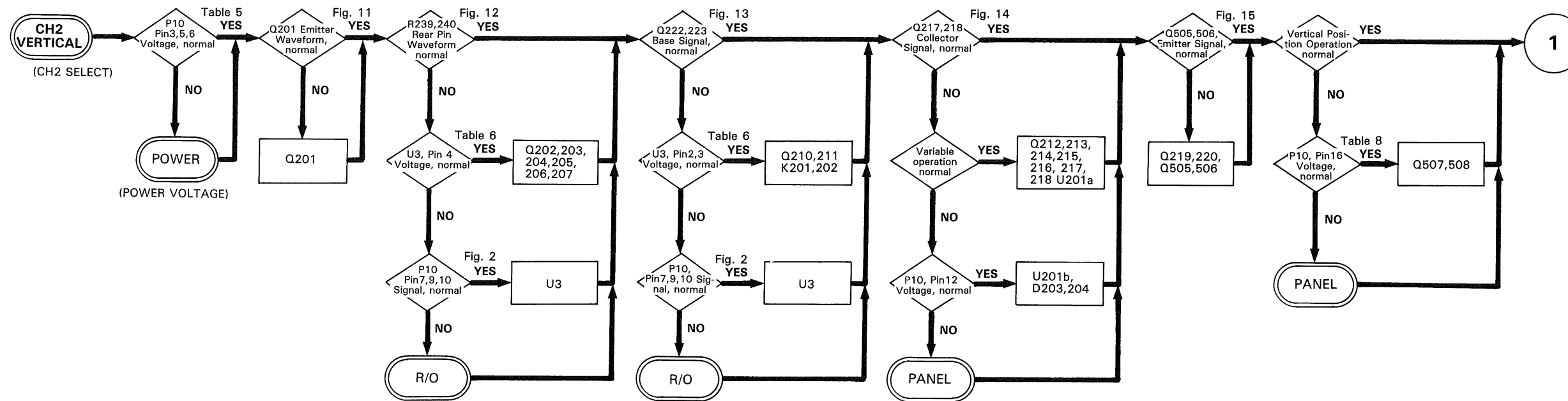

Fig. 11 DC +6V

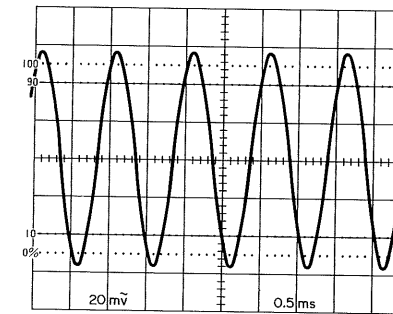

Fig. 12 DC -1.8V

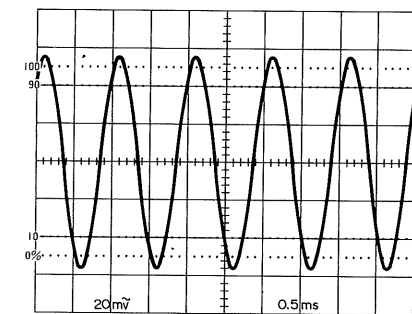

Fig. 13 DC -1.8V

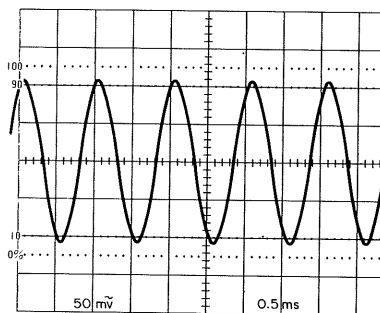

Fig. 14 DC +4.8V

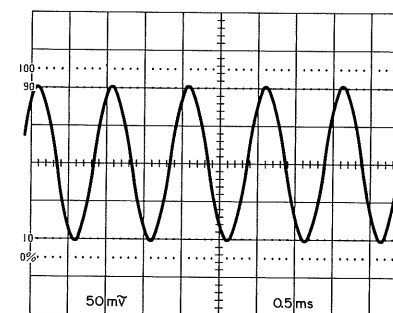
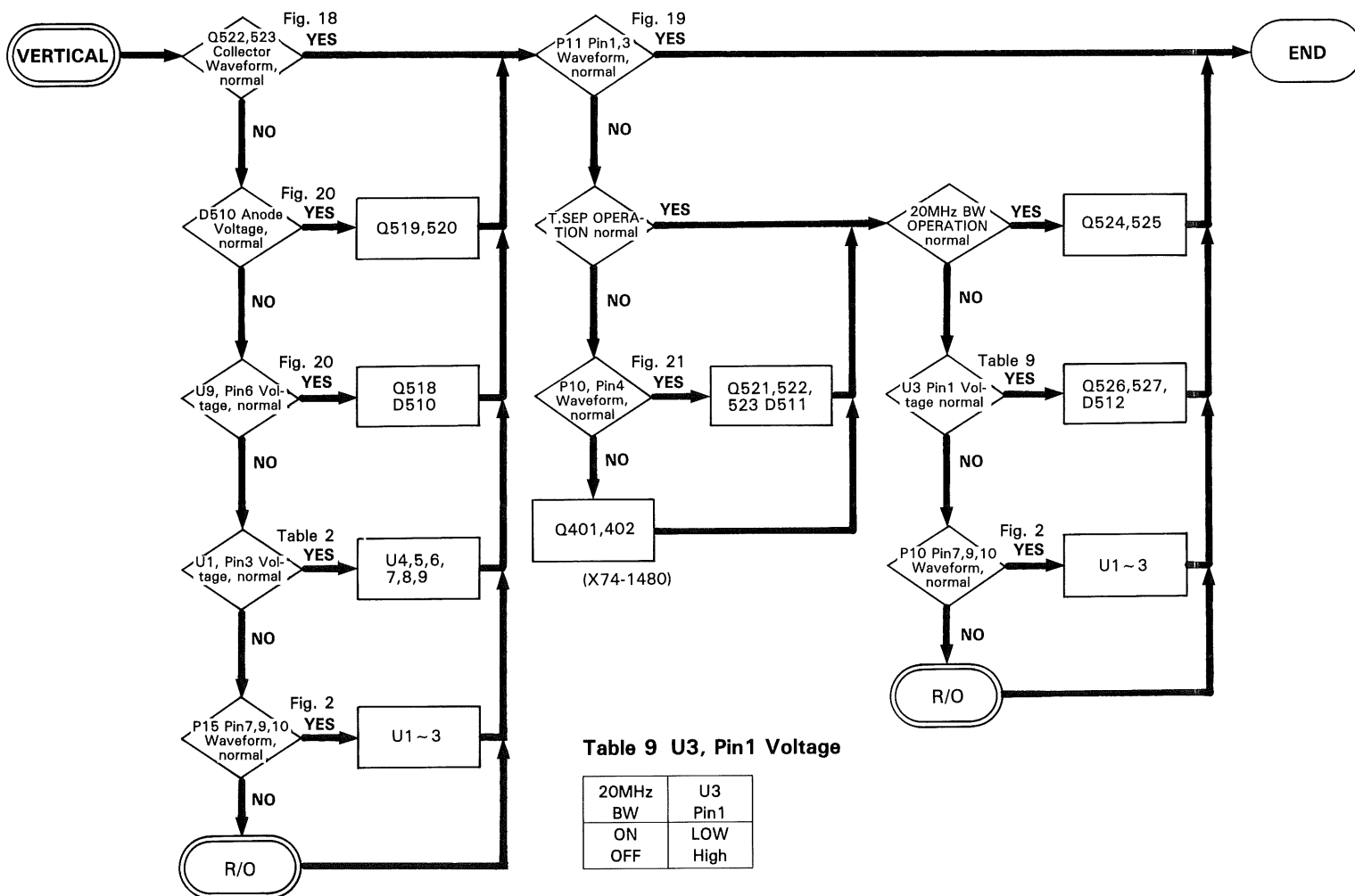
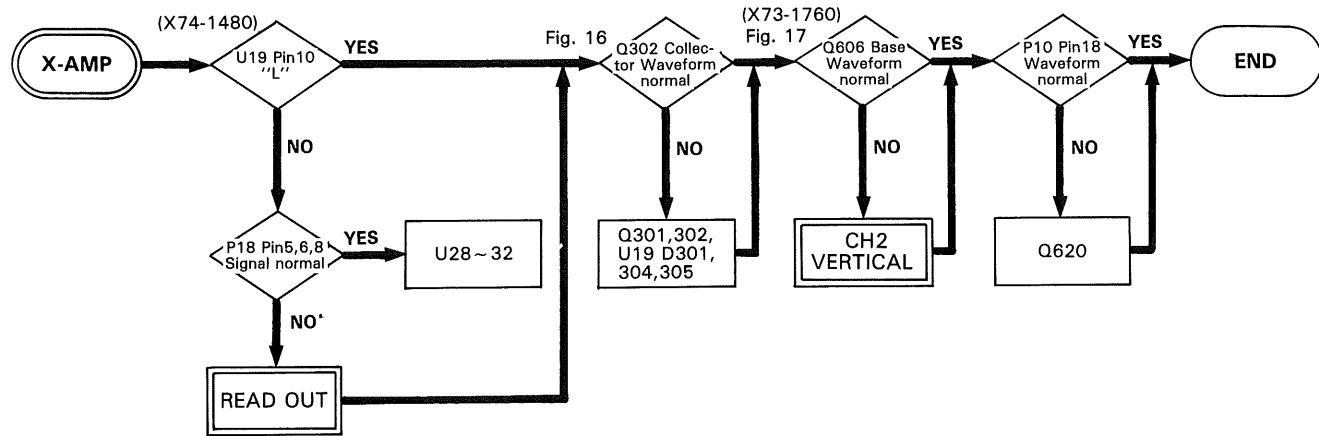

Fig. 15 DC +4.8V

TROUBLESHOOTING



H-MODE "X-Y"
Input: 40mVp-p 1kHz
Sine Wave
Volts/div: 5mV/div

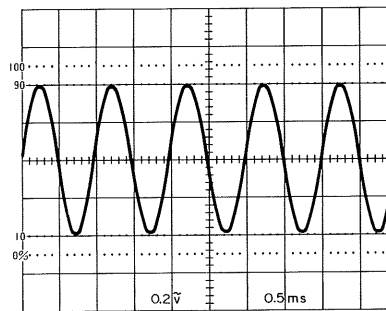

Fig. 16 DC + 2.4V

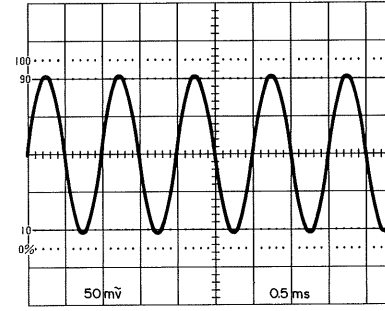

Fig. 17 DC + 5V

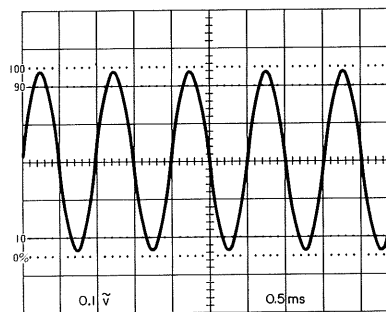

Fig. 18 DC - 5.0V

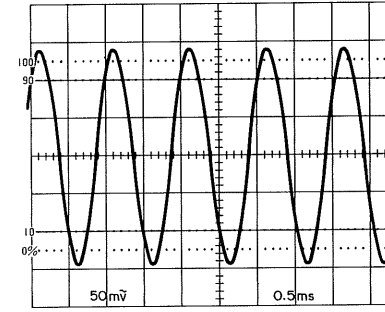
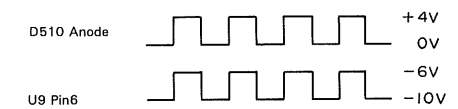
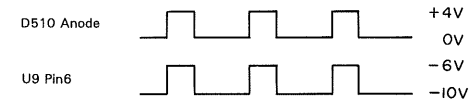

Fig. 19 DC + 5V



(a) V-MODE "ADD" + The other one



(b) V-MODE "ADD" + CH x 2

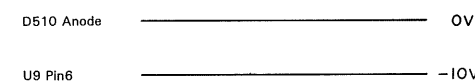

(c) V-MODE "ADD" is not selected

Fig. 20 D510 Anode, U9, Pin6 Waveform



(a) T. SEP FULLY CCW

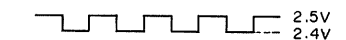

(b) T. SEP FULLY CW

Fig. 21 T. SEP. P10 Pin4 Waveform
H-MODE "ALT"

TROUBLESHOOTING

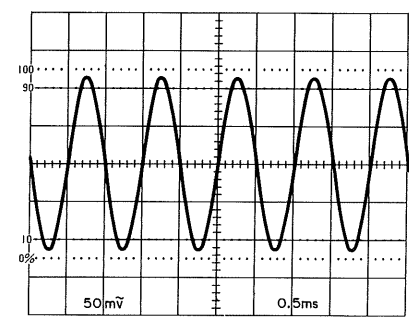
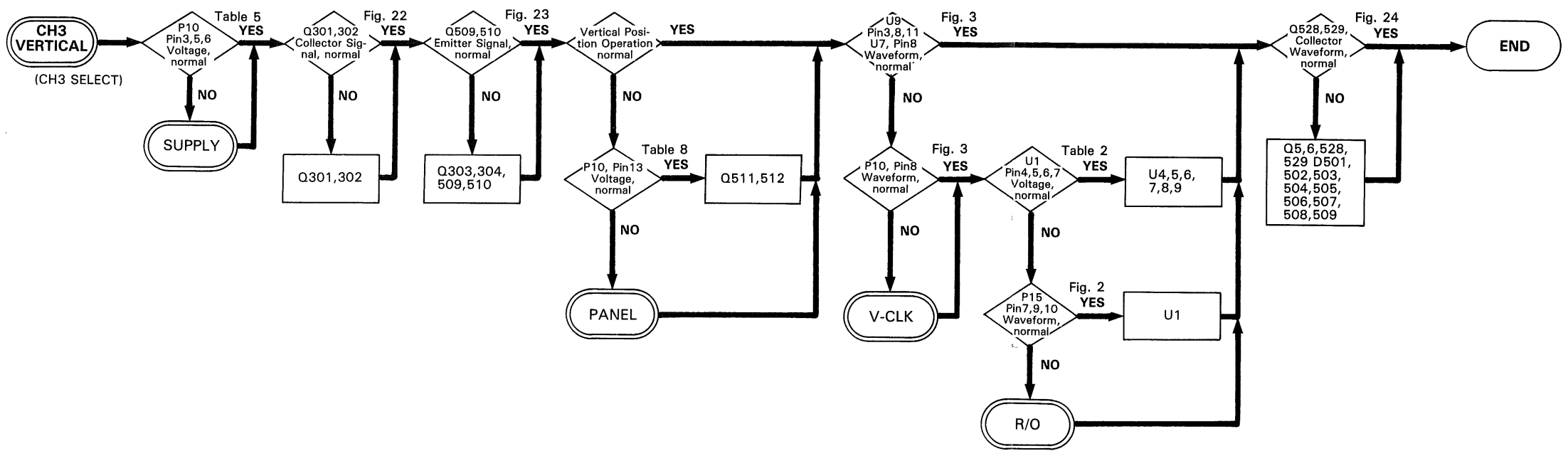

Fig. 22 DC - 5.0V

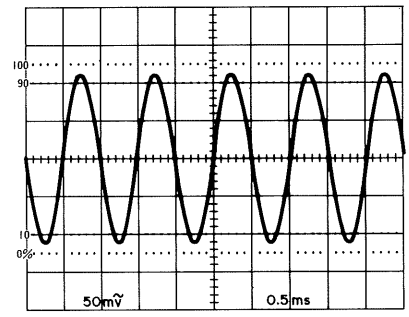

Fig. 23 DC + 5.0V

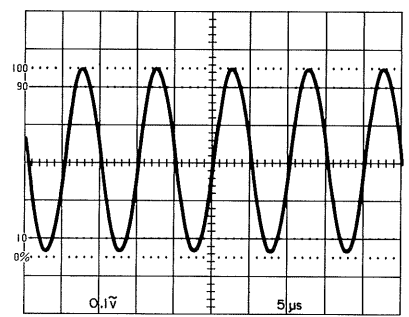
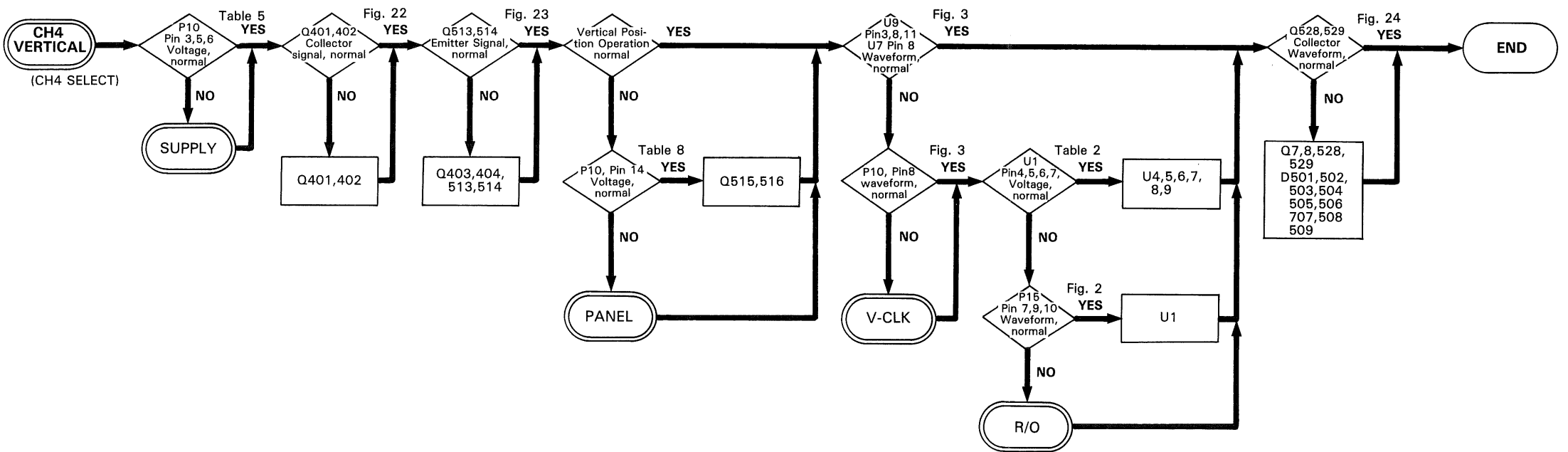

Fig. 24 DC - 5.0V
Input 0.8Vp-p Sine Wave

TROUBLESHOOTING

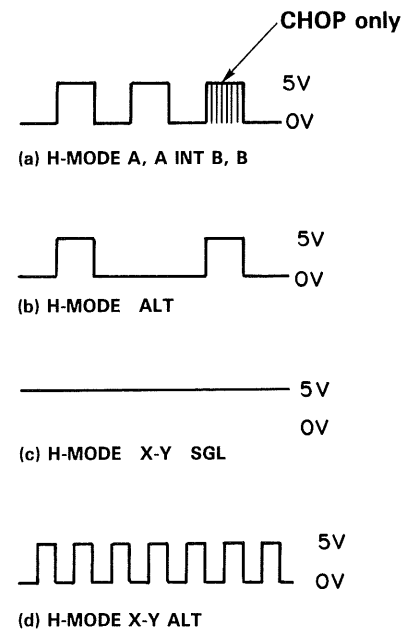
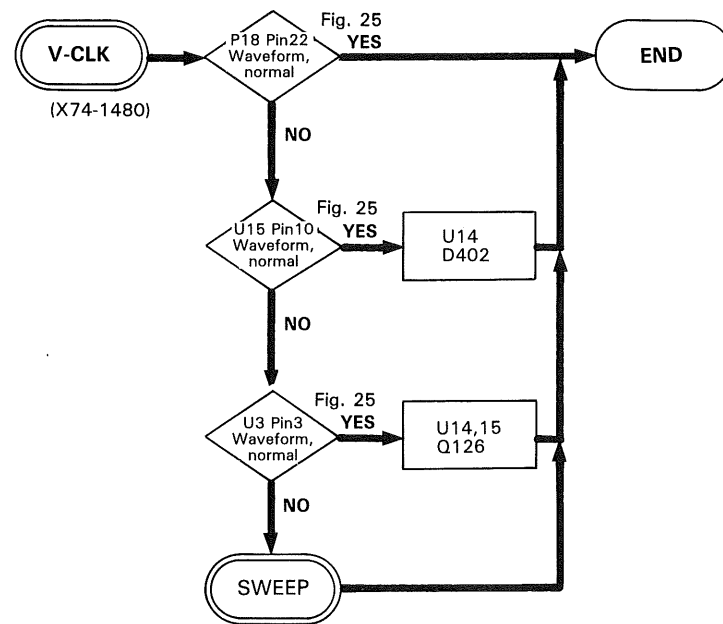

Fig. 25 Waveform

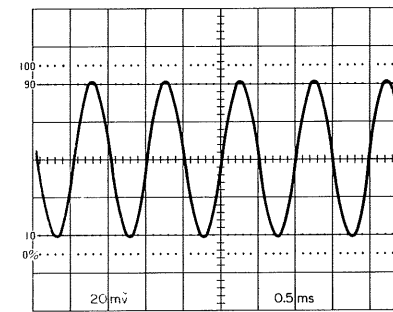

Fig. 26 DC +5V

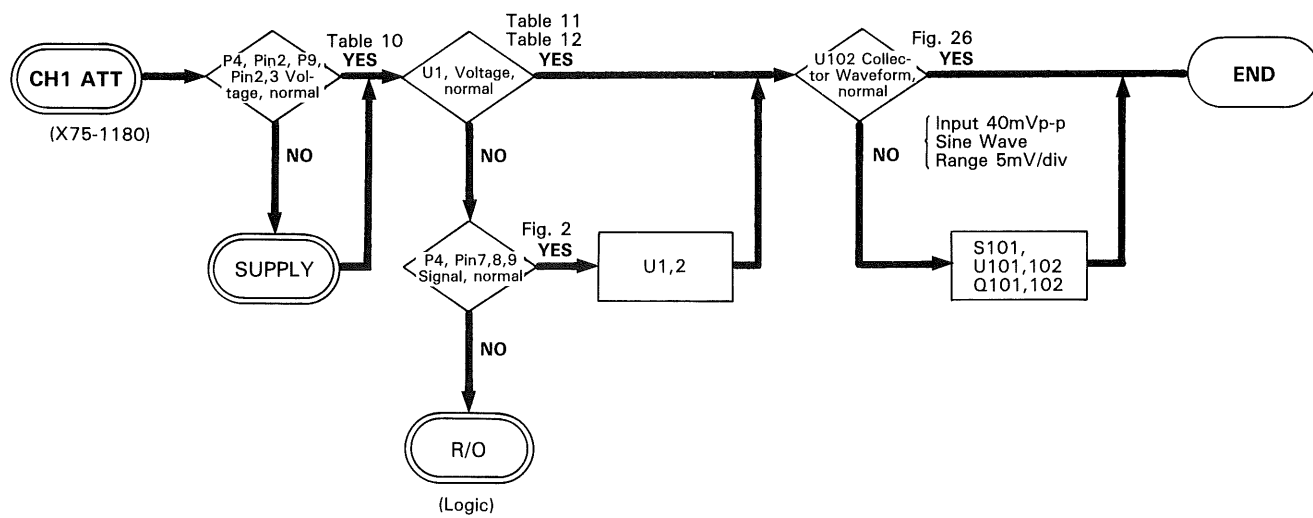

Table 10 INPUT Voltage

Ref. No.	Pin No.	Voltage [V]
P4	2	+5
P9	2	-10
P9	3	+10

Table 11

Volts/div	X75-1180		X73-1760			
	1/10 ATT	1/100 ATT	× 5 Amp	× 1 Amp	1/2 ATT	1/4 ATT
1mV			○		○	
2			○		○	
5				○	○	
10				○	○	
20				○	○	○
50	○			○	○	○
0.1V	○			○	○	○
0.2	○			○	○	○
0.5		○		○	○	○
1.0		○		○	○	○
2.0		○		○	○	○
5.0	○	○		○	○	○

Table 12 U1, U2 FUNCTION

Pin No.	U1	U2
1	CH2 GND	
2	CH2 1/10	CH3 1/5
3	CH2 1/100	CH4 1/5
4	CH1 AC/DC	CH2 INV
5	CH1 GND	
6	CH1 1/10	
7	CH1 1/100	
15	CH2 AC/DC	

TROUBLESHOOTING

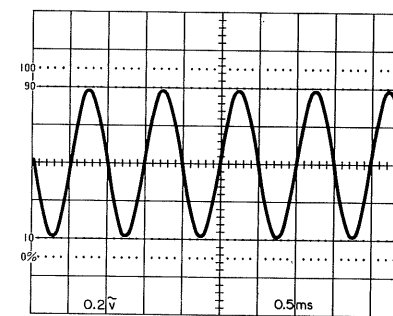
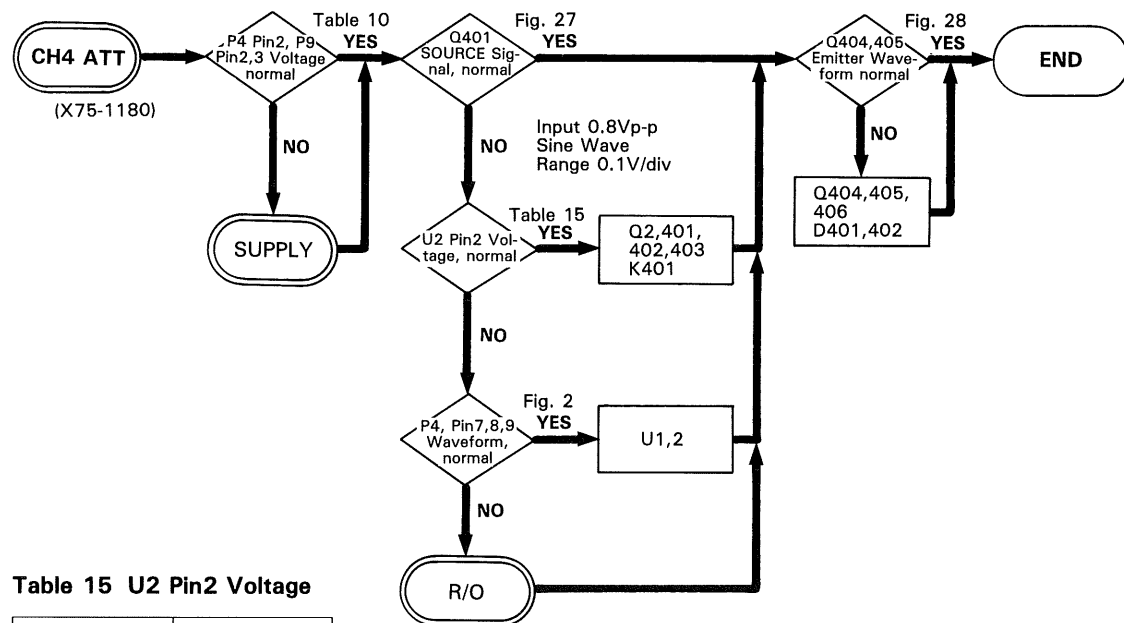
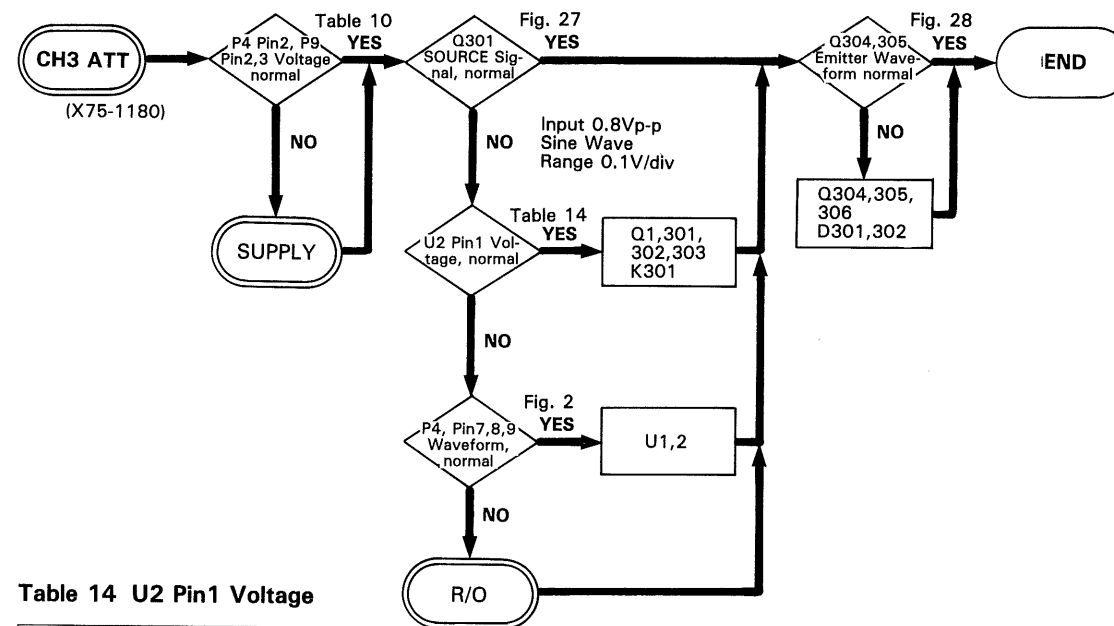
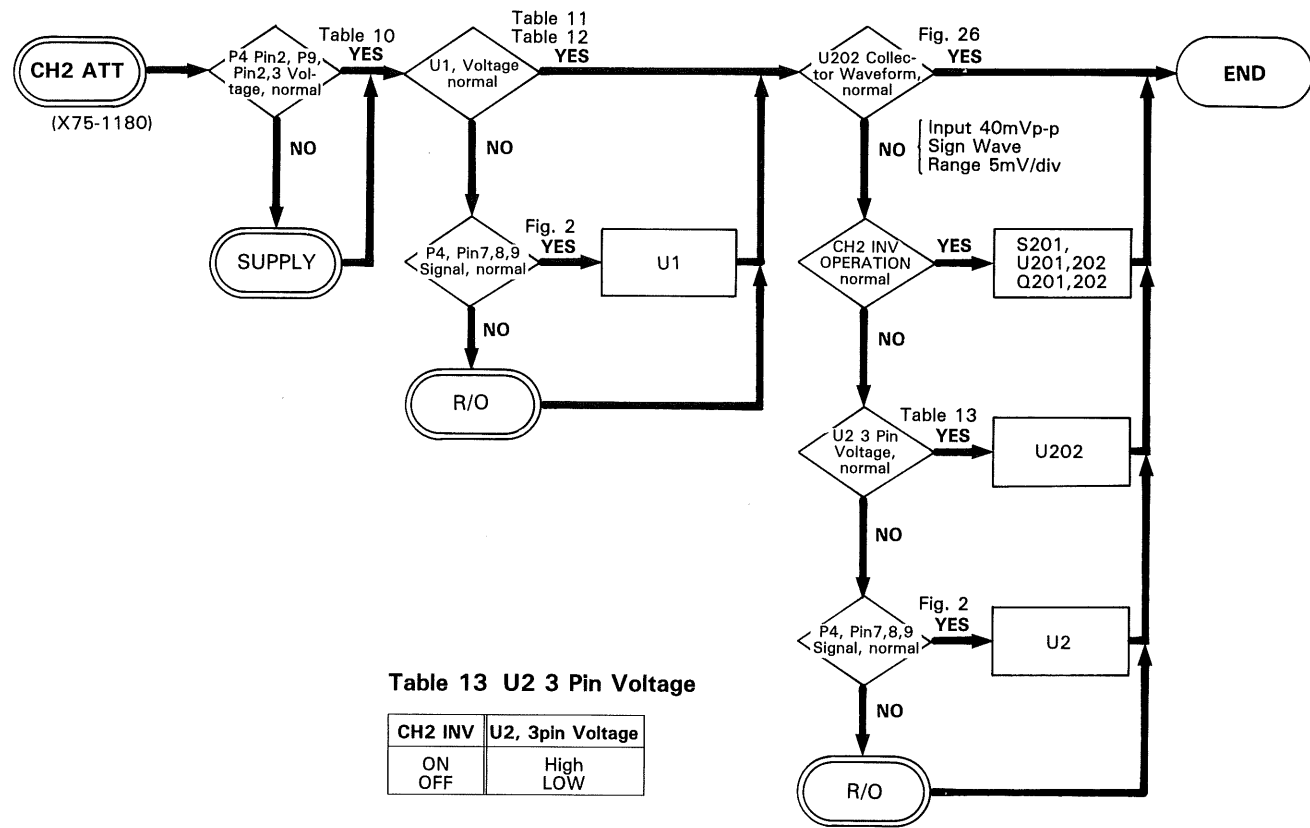

Fig. 27 DC - 0.27 V

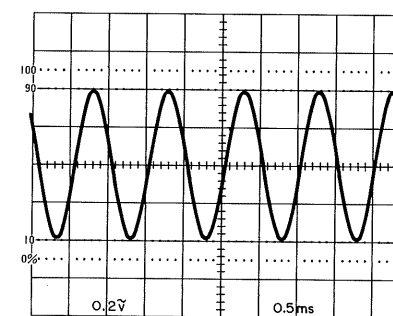

Fig. 28 DC - 1.0 V

TROUBLESHOOTING

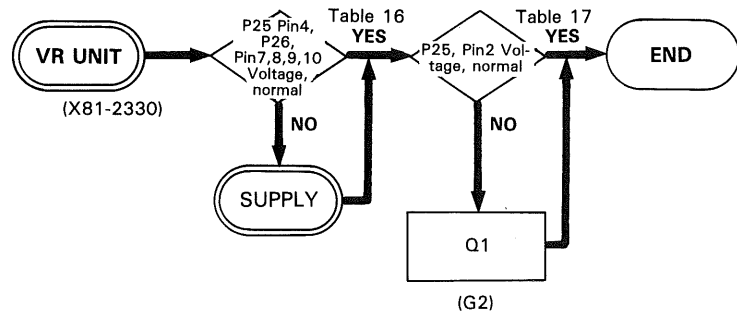

Table 16 Voltage

P25 Pin No.	Voltage [V]
4	+ 140
P26 Pin No.	Voltage [V]
7	+ 10
8	- 10
9	+ 13
10	- 13

Table 17 Voltage

P25 Pin No.	Voltage [V]
Pin 2	+ 20

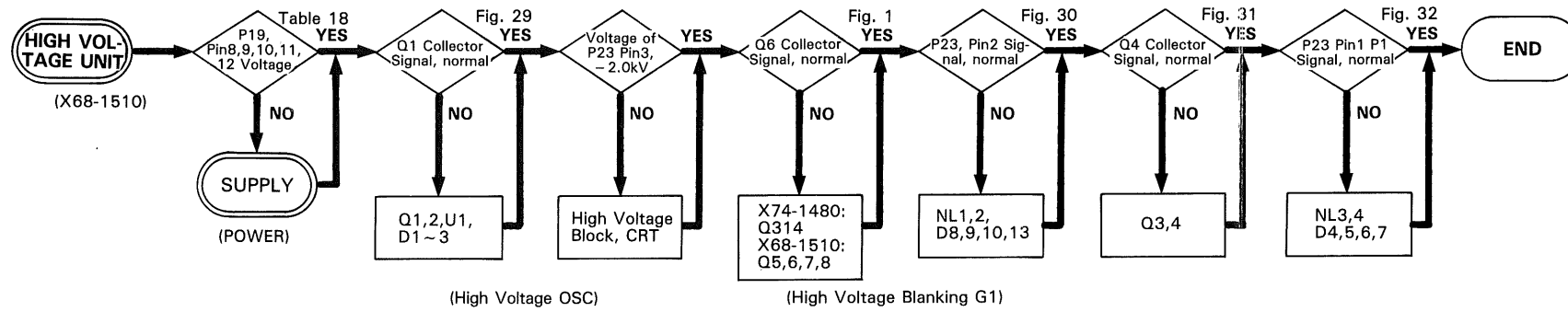

Table 18

P19 Pin No.	Voltage [V]
8	+ 10
9	- 10
10	+ 13
11	- 13
12	+ 140

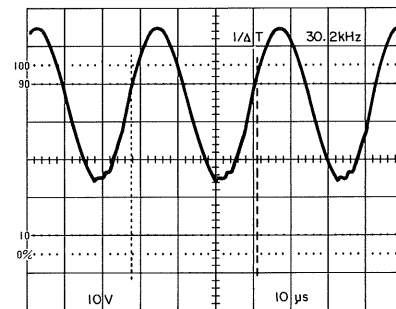

Fig. 29 Q1, Collector Waveform



Fig. 30 G1, P23, Pin2

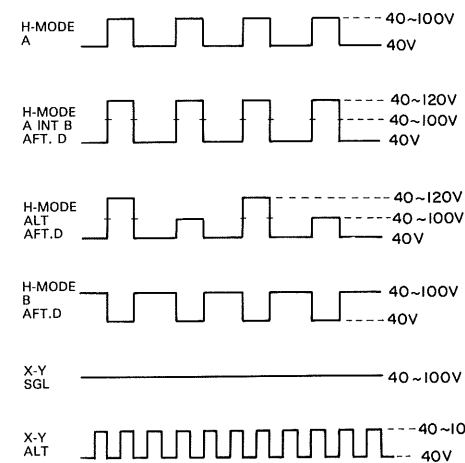

Fig. 31 Q4, Collector Signal

A SWEEP TIME = B SWEEP TIME
DELAY TIME MIN



Fig. 32 P1, P23, Pin1 Signal

TROUBLESHOOTING

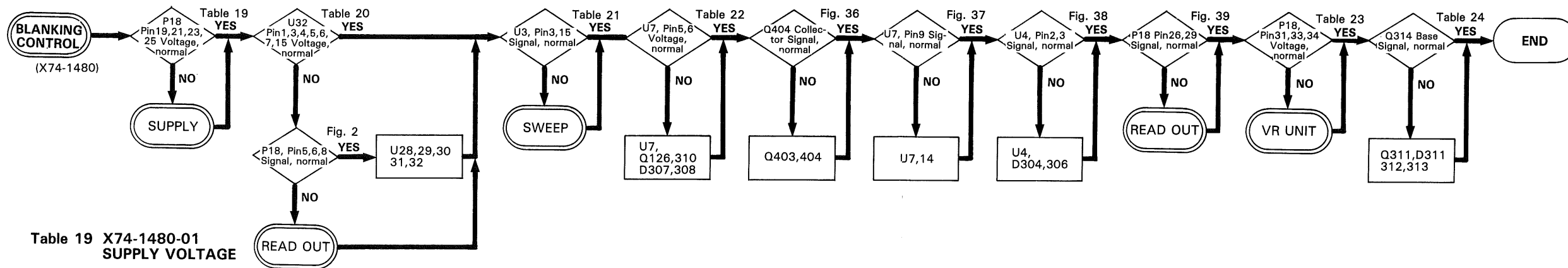

Table 19 X74-1480-01 SUPPLY VOLTAGE

P18	Voltage [V]
Pin 19	+ 5
Pin 21	+ 5
Pin 23	+10
Pin 25	-10

Table 20 U32 Pin VOLTAGE

HORIZ DISPLAY MODE	ALT Pin1	B Pin3	XY SGL Pin4	ATT. D Pin5	A Pin6	CHOP Pin15
A	H	H	L	H	L	V-MODE ALT "H"
A INT B	NORM	H	L	H	H	V-MODE CHOP "L"
	AFT. D	H	L	L	H	
ALT	NORM	L	H	L	H	V-MODE CHOP "L"
	AFT. D	L	H	L	H	
B	NORM	H	L	L	H	
	AFT. D	H	L	L	H	
X-Y	SINGLE	H	H	H	H	
	ALT	H	H	L	H	

Table 21 U3 Pin3, 15

HORIZ DISPLAY MODE	AS Pin3	BS Pin15
A	Fig. 33	H
A INT B	NORM	Fig. 33
	AFT. D	Fig. 34
ALT	NORM	Fig. 33
	AFT. D	Fig. 34
B	NORM	Fig. 33
	AFT. D	Fig. 34
X-Y	SGL	H

Table 23 A,B, R/O INTEN Voltage

	FULLY CW INTEN MAX	FULLY CCW INTEN MIN
A INTEN P18 Pin33	-10V ~ +10V	
B INTEN P28 Pin34	-10V ~ +10V	
R/O INTEN P18 Pin31	-10V ~ +10V	

Table 22 A STATE, B STATE

HORIZ DISPLAY MODE	B STATE U7 Pin 5	A STATE U7 Pin6
A	H	L
A INT B	H	L
ALT		
B	L	H
X-Y	H	L

Table 24 Q314 Base Signal

HORIZ DISPLAY MODE	Q314 Base Signal
A	Fig. 35
A INT B AFT. D	Fig. 35
ALT AFT.D	Fig. 35
B AFT.D	Fig. 35
X-Y	0.5 ~ 1.8V

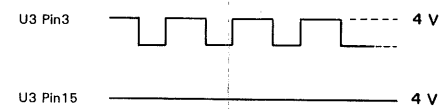

Fig. 33 HORIZ MODE "A"

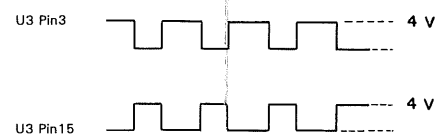

Fig. 34 HORIZ MODE "A INT B" "ALT" AFT D, Delay time Min B SWEEP TIME = A SWEEP TIME

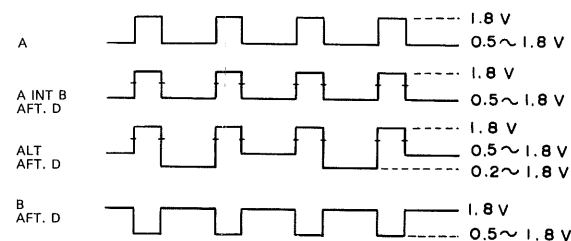

Fig. 35 Q314 Base Signal

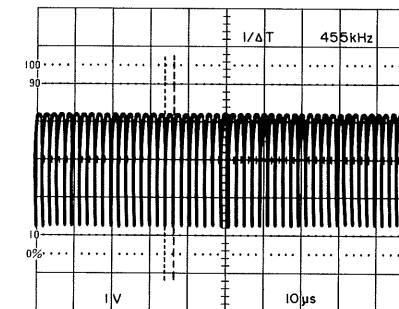

Fig. 36 Q404 Collector Signal

TROUBLESHOOTING

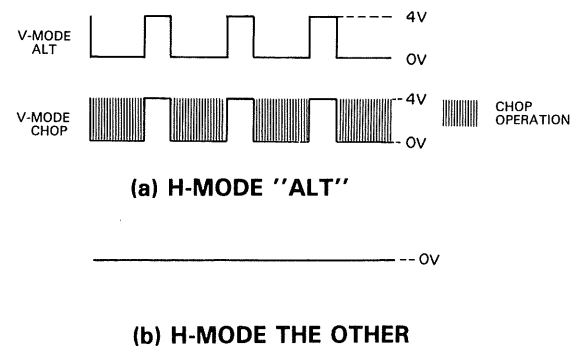

Fig. 37 U7, Pin9 Signal

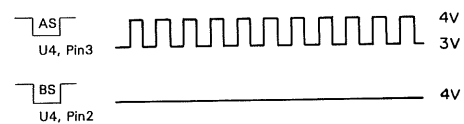
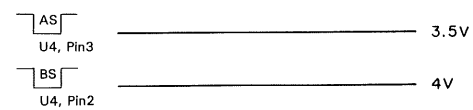
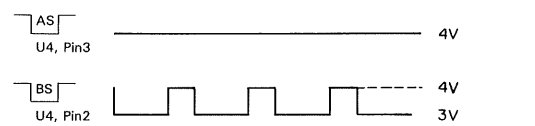
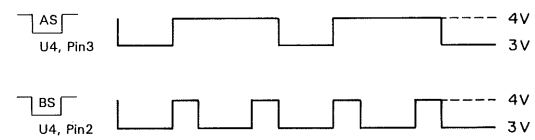
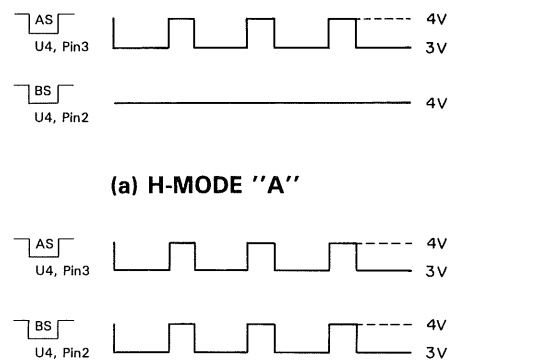

Fig. 38 U4, Pin2,3 Signal

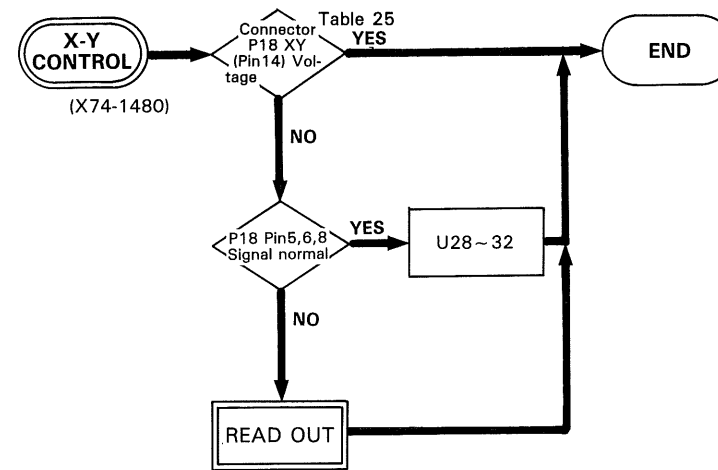
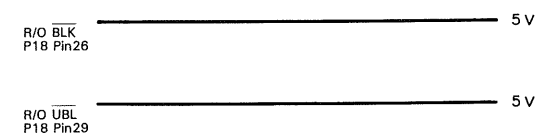
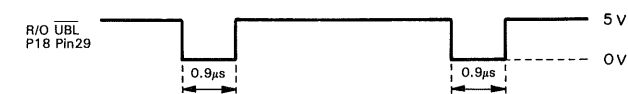
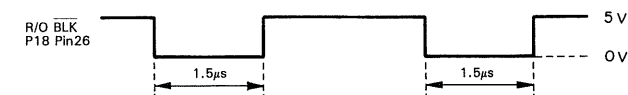

Table 25 X-Y Signal

X-Y	P18 Pin14 X-Y
ON	L
OFF	H



(b) R/O OFF

Fig. 39 P18 Pin26, 29, R/O BLK, R/O UBL Signal

TROUBLESHOOTING

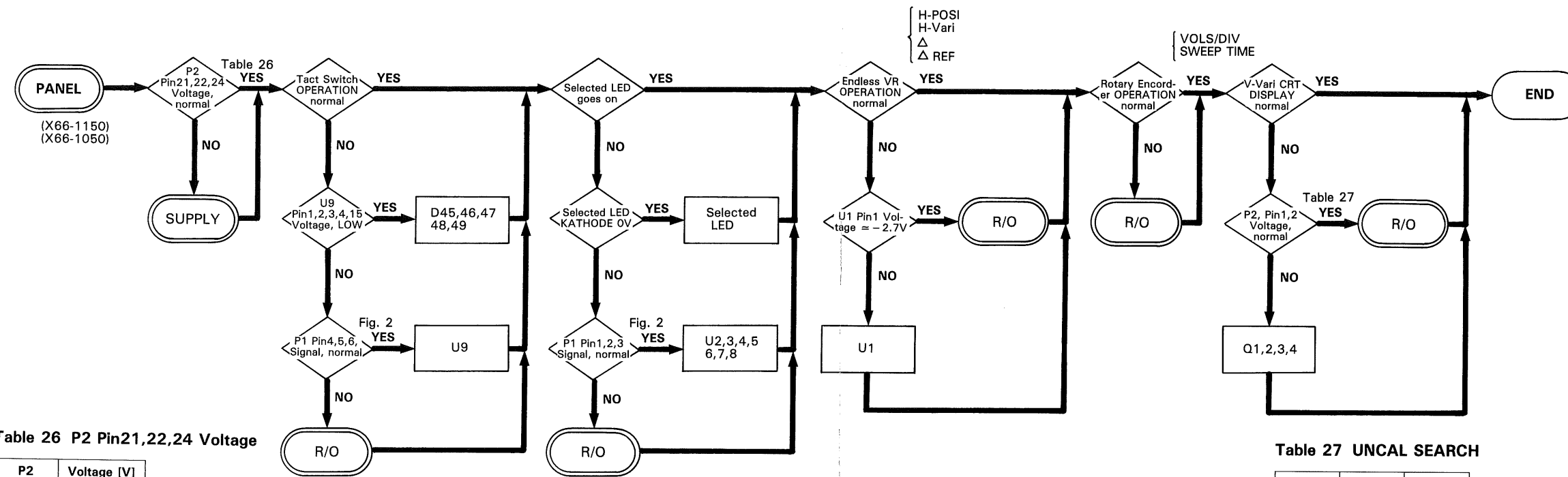

Table 26 P2 Pin21,22,24 Voltage

P2	Voltage [V]
Pin 21	+10
22	-10
24	+5

Table 27 UNCAL SEARCH

	CH1 P2, Pin1	CH2 P2, Pin2
CAL	+0.12 [V]	+0.12 [V]
UNCAL	+4.85 [V]	+4.85 [V]

TROUBLESHOOTING

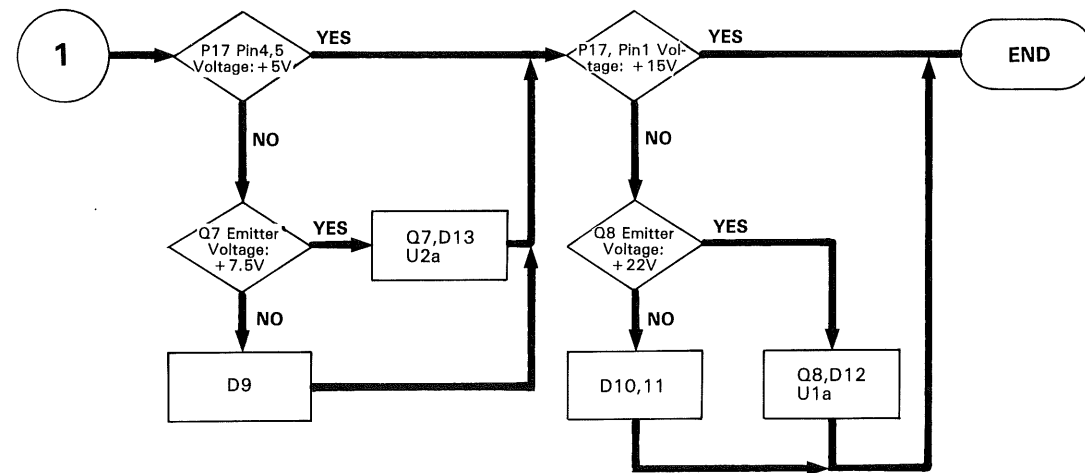
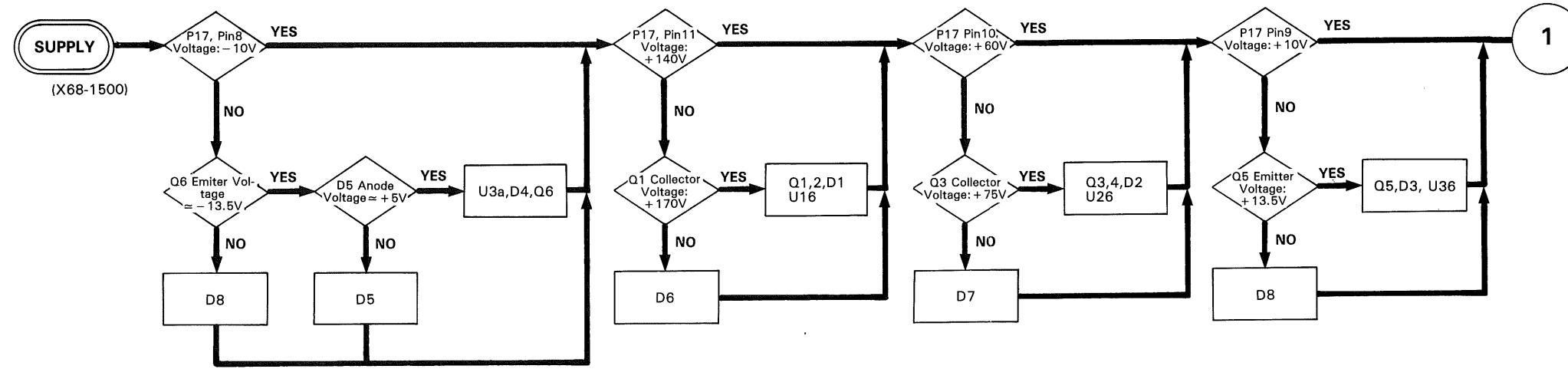

TROUBLESHOOTING

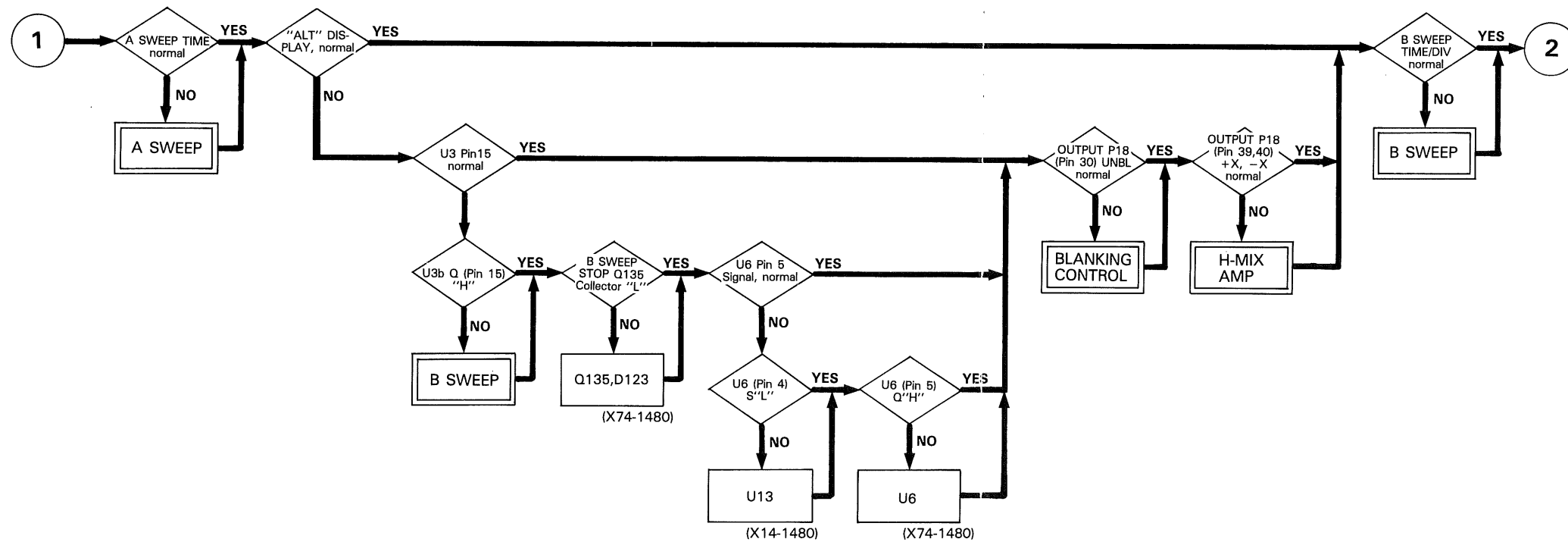
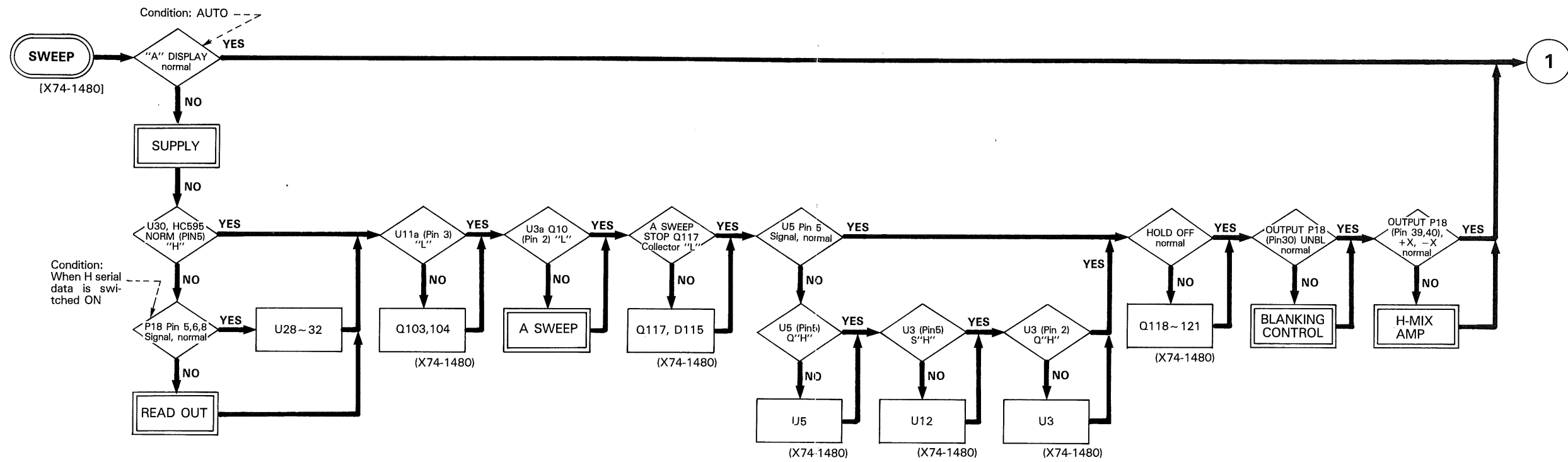

TROUBLESHOOTING

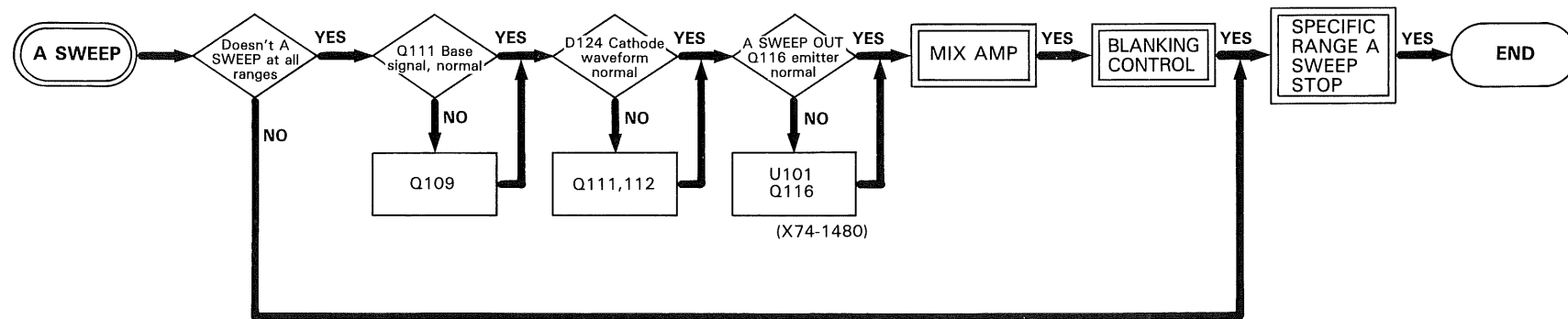
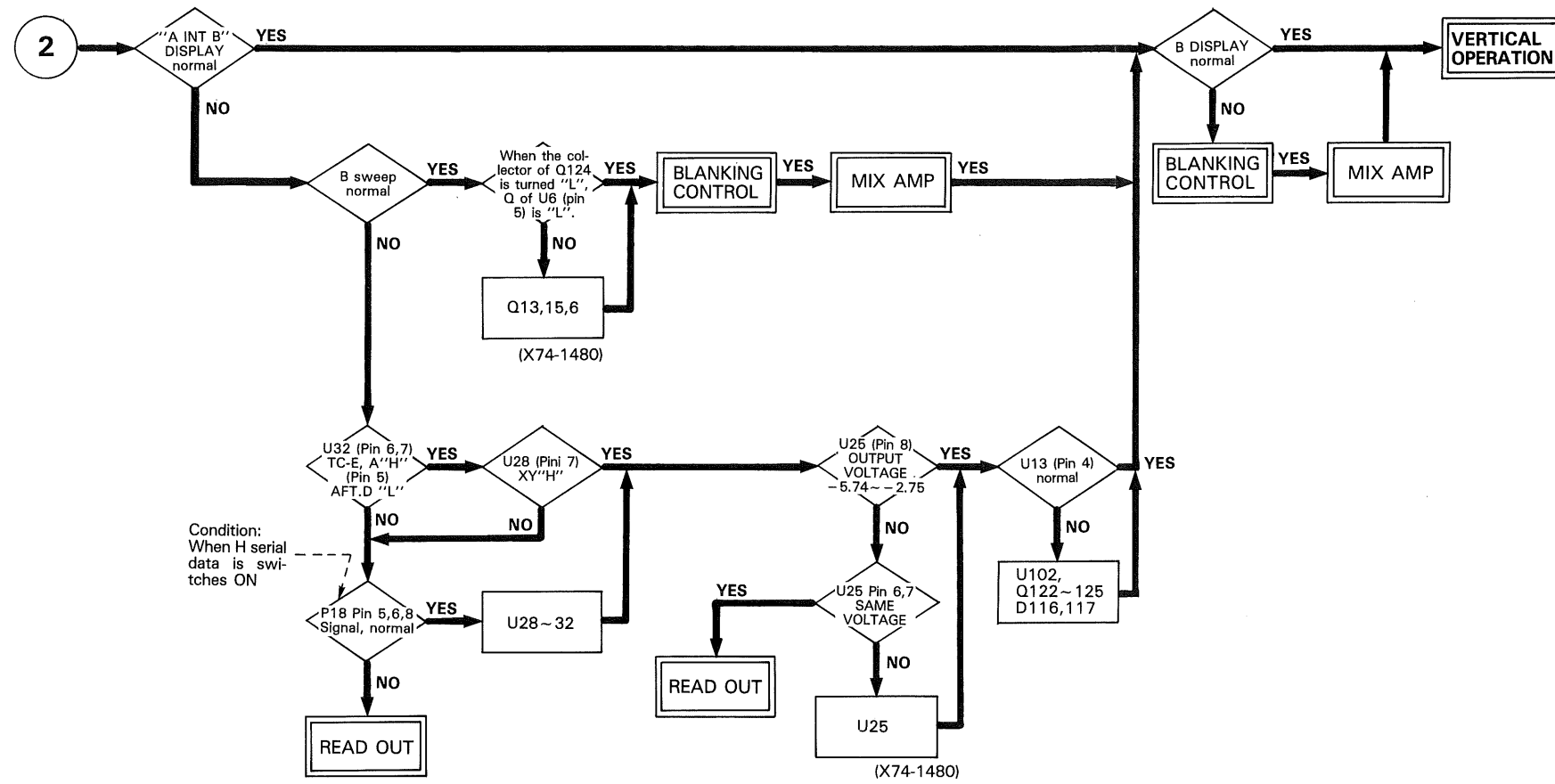

TROUBLESHOOTING

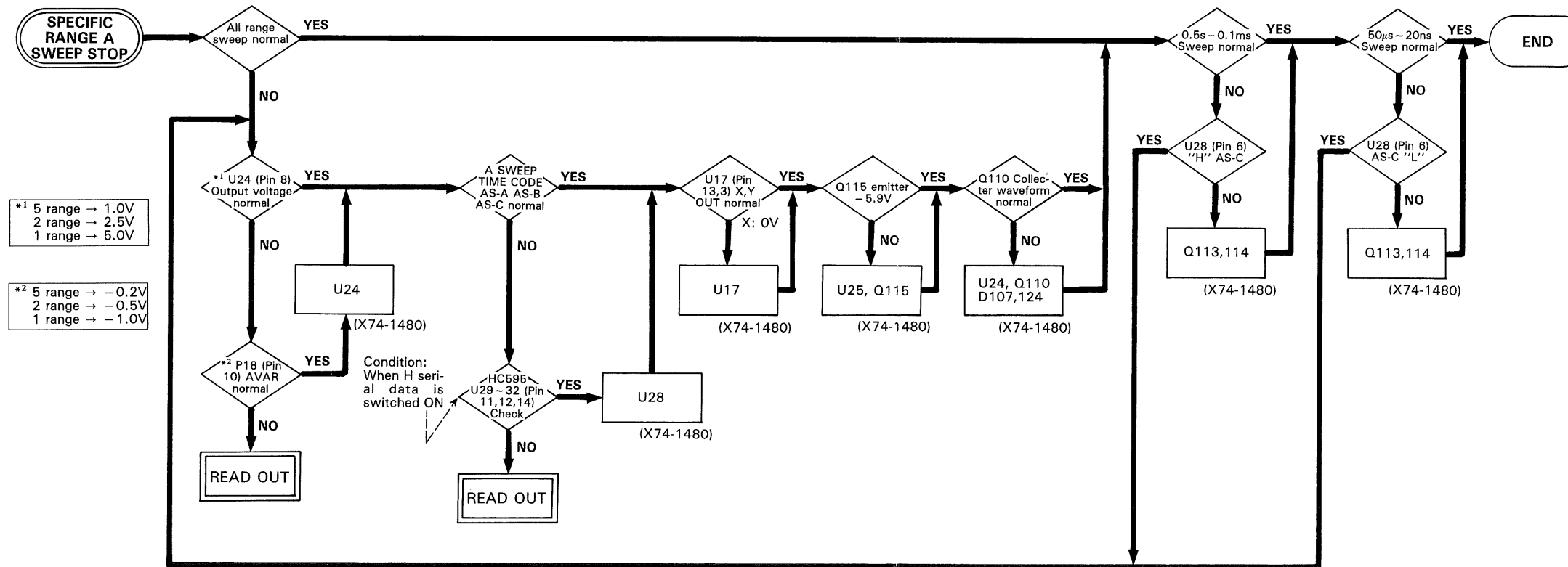
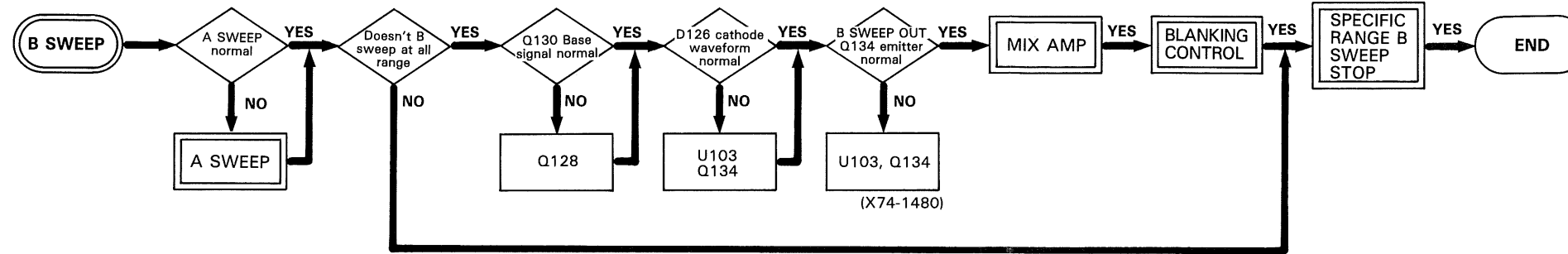

TROUBLESHOOTING

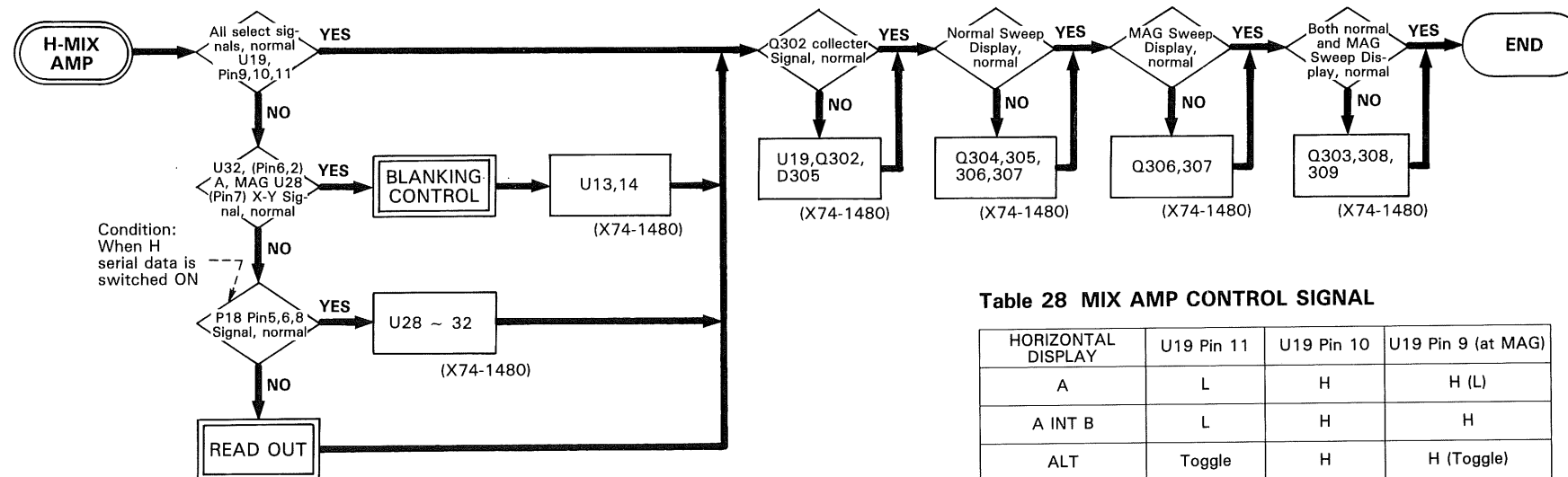
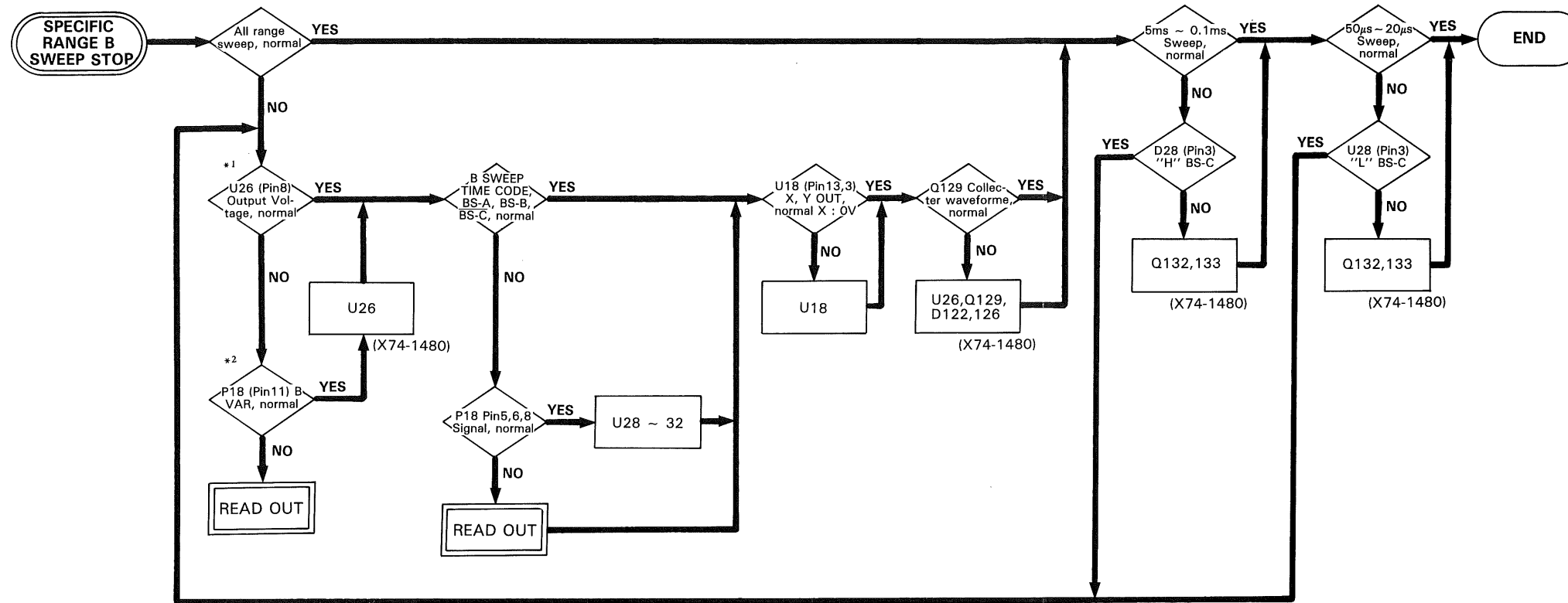
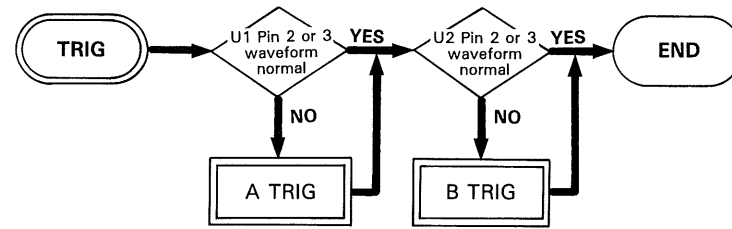

Table 28 MIX AMP CONTROL SIGNAL

HORIZONTAL DISPLAY	U19 Pin 11	U19 Pin 10	U19 Pin 9 (at MAG)
A	L	H	H (L)
A INT B	L	H	H
ALT	Toggle	H	H (Toggle)
B	H	H	H (L)
X-Y	L	L	H

TROUBLESHOOTING



TROUBLESHOOTING

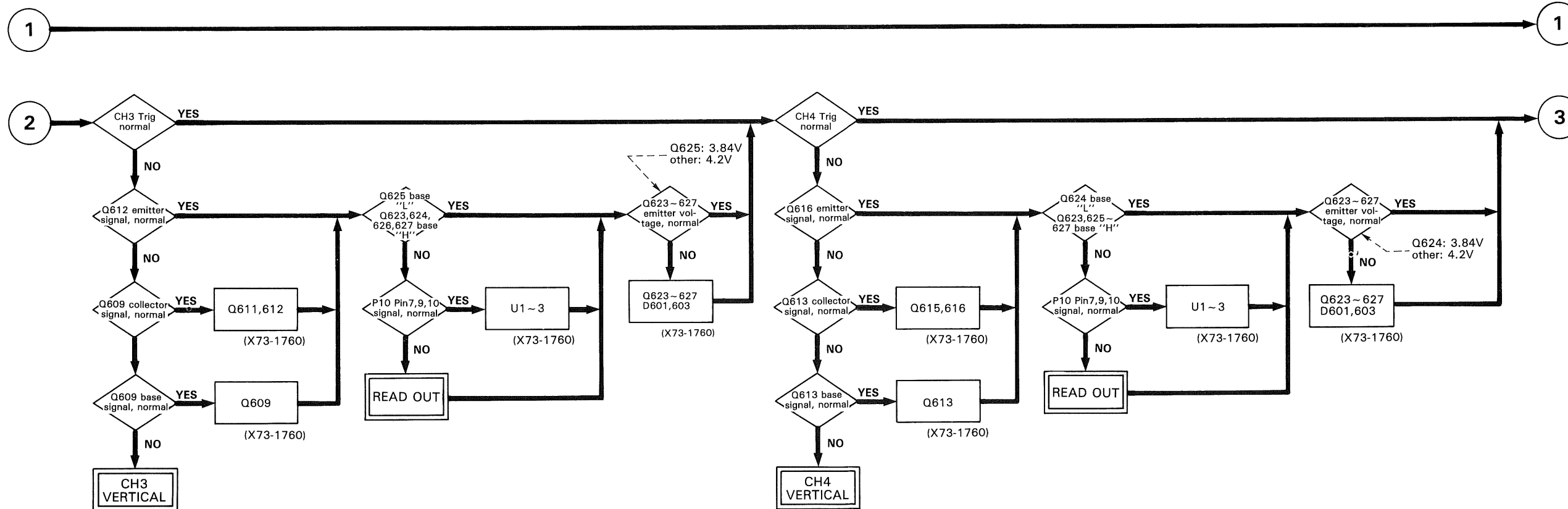
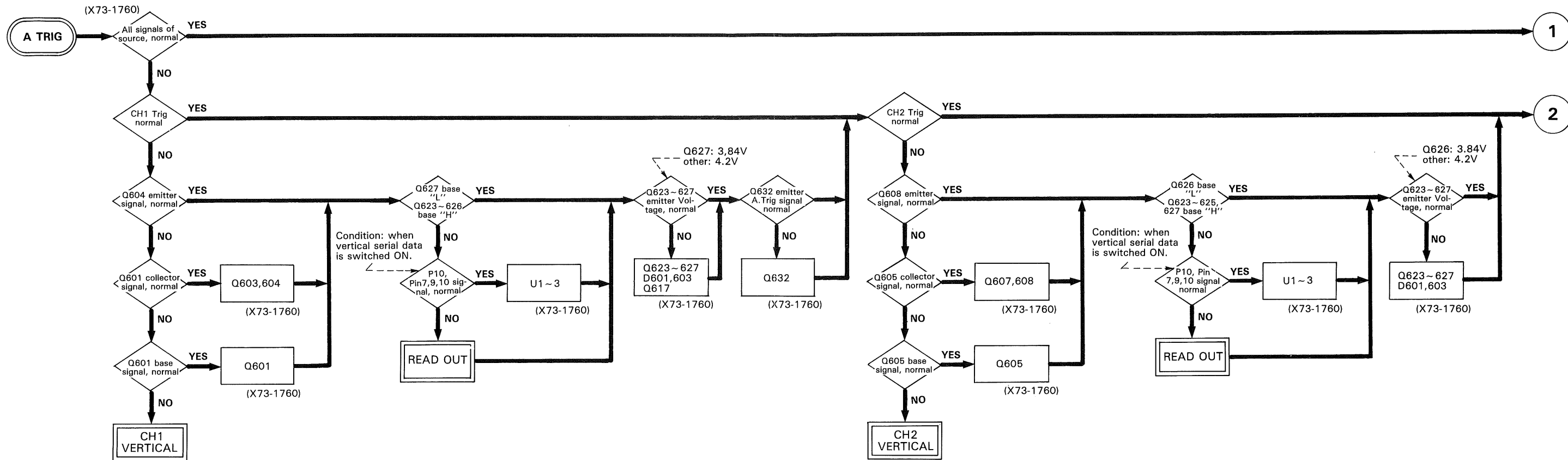

TROUBLESHOOTING

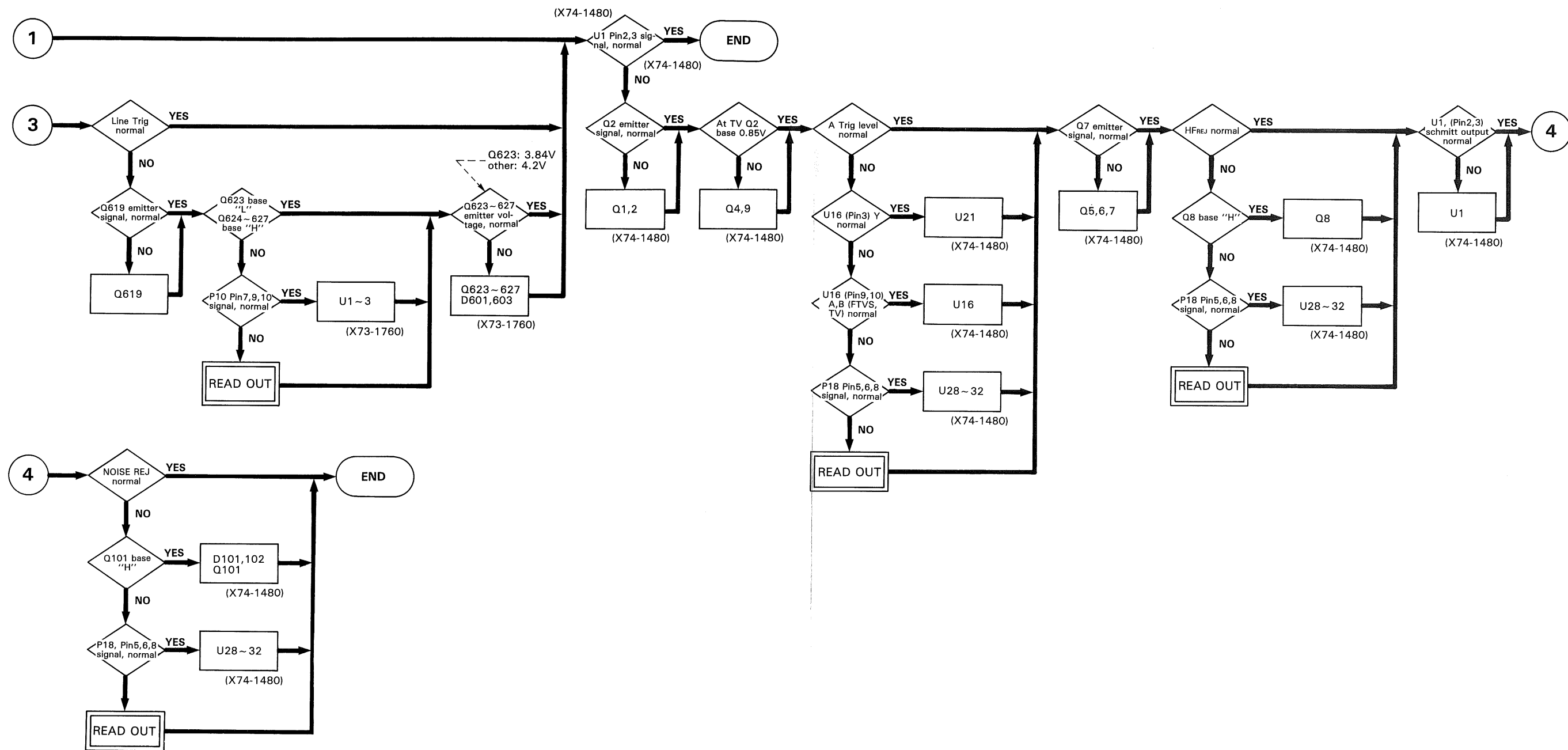

TROUBLESHOOTING

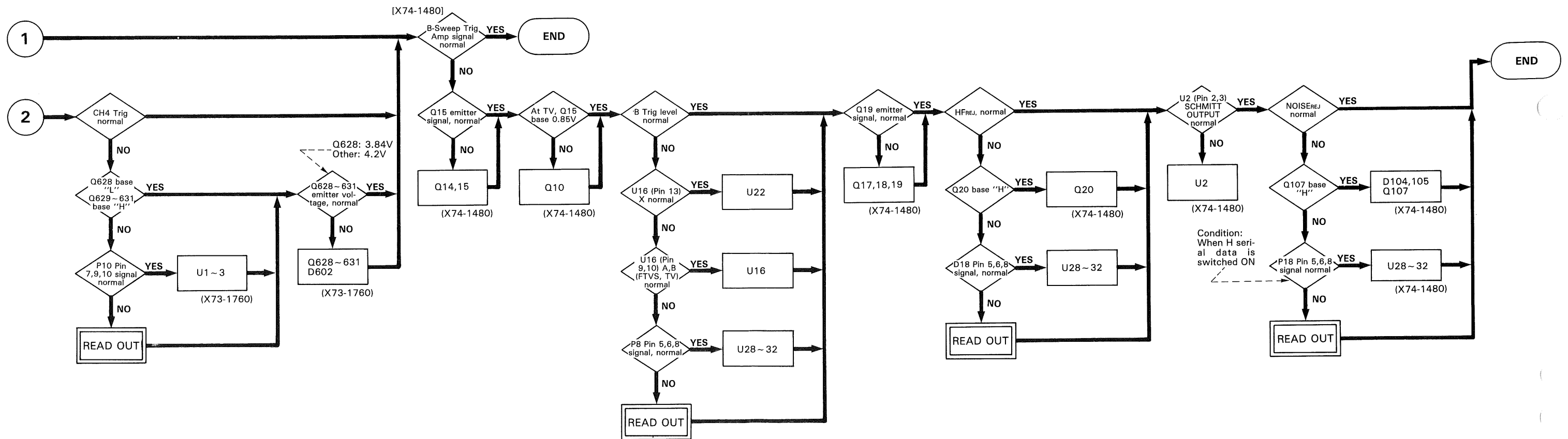
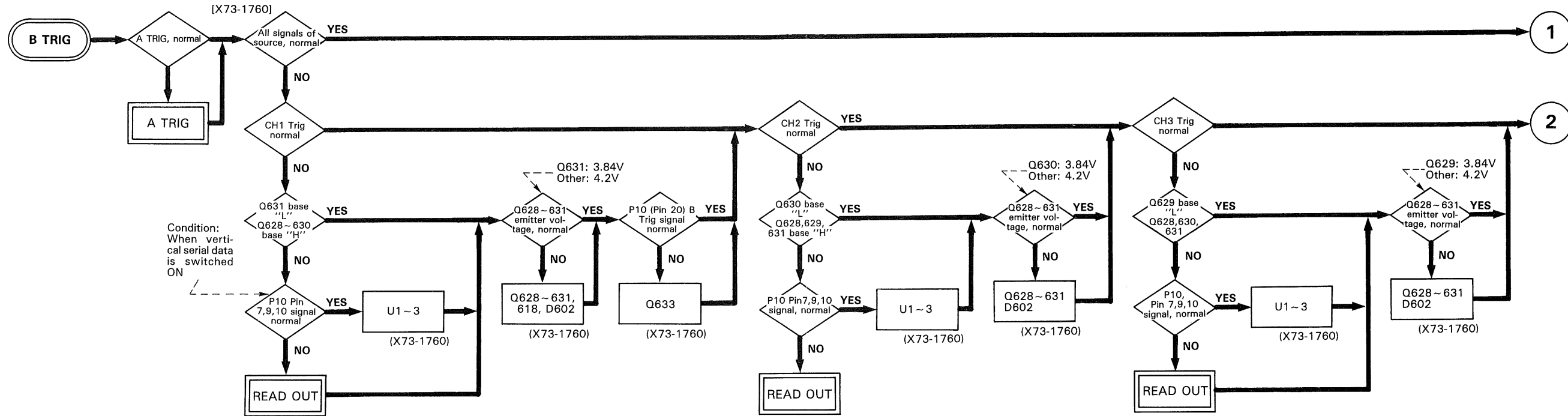

TROUBLESHOOTING

ATT Unit Serial Data Active Level

ATT Code (CH1 and CH2)

	1/2* U3 Pin6 (U3 Pin3)	1/4* U3 Pin5 (U3 Pin2)	1/10 U1 Pin6 (U1 Pin2)	1/100 U1 Pin7 (U1 Pin3)	MAG* U3 Pin7 (U3 Pin4)	CH1 (CH2) Display
1 mV	L	L	L	L	L	1 mV
2 mV	H	L	L	L	L	2 mV
5 mV	L	L	L	L	H	5 mV
10 mV	H	L	L	L	H	10 mV
20 mV	L	H	L	L	H	20 mV
50 mV	L	L	H	L	H	50 mV
0.1 V	H	L	H	L	H	0.1 V
0.2 V	L	H	H	L	H	0.2 V
0.5 V	L	L	L	H	H	0.5 V
1 V	H	L	L	H	H	1 V
2 V	L	H	L	H	H	2 V
5 V	L	L	H	H	H	5 V

() CH2
*1/2, 1/4, MAG Signal Vertical Unit IC.

ATT Code (CH3 and CH4)

	CH3 U2 Pin1	CH4 U2 Pin2	Display
0.1V	H	H	0.1
0.5V	L	L	0.5

CH1,CH2 Coupling	Active	Output IC	Display
CH1 AC	L	U1 Pin4	mV or \bar{V}
CH1 GND	L	U1 Pin5	$\bar{\bar{V}}$
CH2 AC	L	U1 Pin15	mV or \bar{V}
CH2 GND	L	U1 Pin1	$\bar{\bar{V}}$

CH2 Polarity	U2 Pin3	Display
Normal	H	space
Invert	L	space

Vertical Unit Serial Data Active Level

A-Source	Active	Output IC
CH1	L	U2 Pin 4
CH2	L	U2 Pin 3
CH3	L	U2 Pin 2
CH4	L	U2 Pin 1
LINE	L	U2 Pin 15

B-Source	Active	Output IC
CH1	L	U1 Pin 2
CH2	L	U1 Pin 1
CH3	L	U1 Pin 15
CH4	L	U2 Pin 5

V-Mode	Active	Output IC
CH1E	L	U1 Pin 7
CH2E	L	U1 Pin 6
CH3E	L	U1 Pin 5
CH4E	L	U1 Pin 4
ADDE	L	U1 Pin 3

20MHz BWL	Active	Output IC	Display
BW	L	U3 Pin 1	Bw

Horizontal Unit Serial Data Active Level

(A-Coupling)	Active	Output IC	Condition
AC	L	U29 Pin 7	A Coupling "AC" or A-Source "LINE"
NOISE _{REJ}	H	U29 Pin 5	A-Coupling "NOISE _{REJ} "
HF _{REJ}	H	U29 Pin 6	A-Coupling "HF _{REJ} " or "TV-V" or A-Source "LINE"
TV	H	U29 Pin 4	A-Coupling "TV-V" or "TV-H"
(B-Coupling)			
AC	L	U29 Pin 15	B-Coupling "AC"
NOISE _{REJ}	H	U29 Pin 2	B-Coupling "NOISE _{REJ} "
HF _{REJ}	H	U29 Pin 1	B-Coupling "HF _{REJ} "
FTVS	H	U29 Pin 3	A-Coupling "TV-V" "TV-H" and Slope "-" or "FIX"

ASLOPE	U30 Pin 7
+	H
-	L

B SLOPE	U30 Pin 6
+	H
-	L

SWEEP MODE	U30 Pin 5	Condition
NORMAL	L	Non "AUTO" or "X-Y"

HORIZONTAL MODE	Active	Output IC	Condition	Display
A	L	U32 Pin 6	Horizontal Mode "A"	A Sweep Time
ALT	L	U32 Pin 1	Horizontal Mode "ALT"	A, B Sweep Time
B	L	U32 Pin 3	Horizontal Mode "B"	A, B Sweep Time
X, Y	L	U28 Pin 7	Horizontal Mode "X, Y"	"CH2-X"
X-Y SGL	H	U32 Pin 4	Horizontal Mode "X-Y" and single sweep	

MAG	U32 Pin 2	Condition
normal	H	Horizontal Mode "A INT B" or "X-Y" or MAG normal
X10 MAG	L	

Single Sweep	Active	Output IC
Single	L	U30 Pin 2

CHOP	Active	Output IC
CHOP	L	U30 Pin 15

B (TV)	A (FTVS)	Y	X
0	0	Y0 (ALVL)	Y0 (BLVL)
0	1	Y1 (FIX)	X1 (BLVL) (X0=X1)
1	0	Y2 (TV+)	X2 (TV+)
1	1	Y3 (TV-)	X3 (TV-)

X74-1480
U16 Analog SW Control signal
TV...TV-V or TV-H "H" other "L"
FTVS...Fix or TV SLOPE ⊖ "H" other "L"

SWEEP TIME CODE

Sweep Time	A Sweep Time Code			B Sweep Time Code		
	AS-A	AS-B	AS-C	BS-A	BS-B	BS-C
0.5s	0	0	0			
0.2s	0	0	0			
0.1s	0	0	0			
50ms	1	0	0			
20ms	1	0	0			
10ms	1	0	0			
5ms	0	1	0	0	1	0
2ms	0	1	0	0	1	0
1ms	0	1	0	0	1	0
0.5ms	1	1	0	1	1	0
0.2ms	1	1	0	1	1	0
0.1ms	1	1	0	1	1	0
50μs	0	0	1	0	0	1
20μs	0	0	1	0	0	1
10μs	0	0	1	0	0	1
5μs	1	0	1	1	0	1
2μs	1	0	1	1	0	1
1μs	1	0	1	1	0	1
0.5μs	0	1	1	0	1	1
0.2μs	0	1	1	0	1	1
0.1μs	0	1	1	0	1	1
50ns	1	1	1	1	1	1
20ns	1	1	1	1	1	1

TROUBLESHOOTING

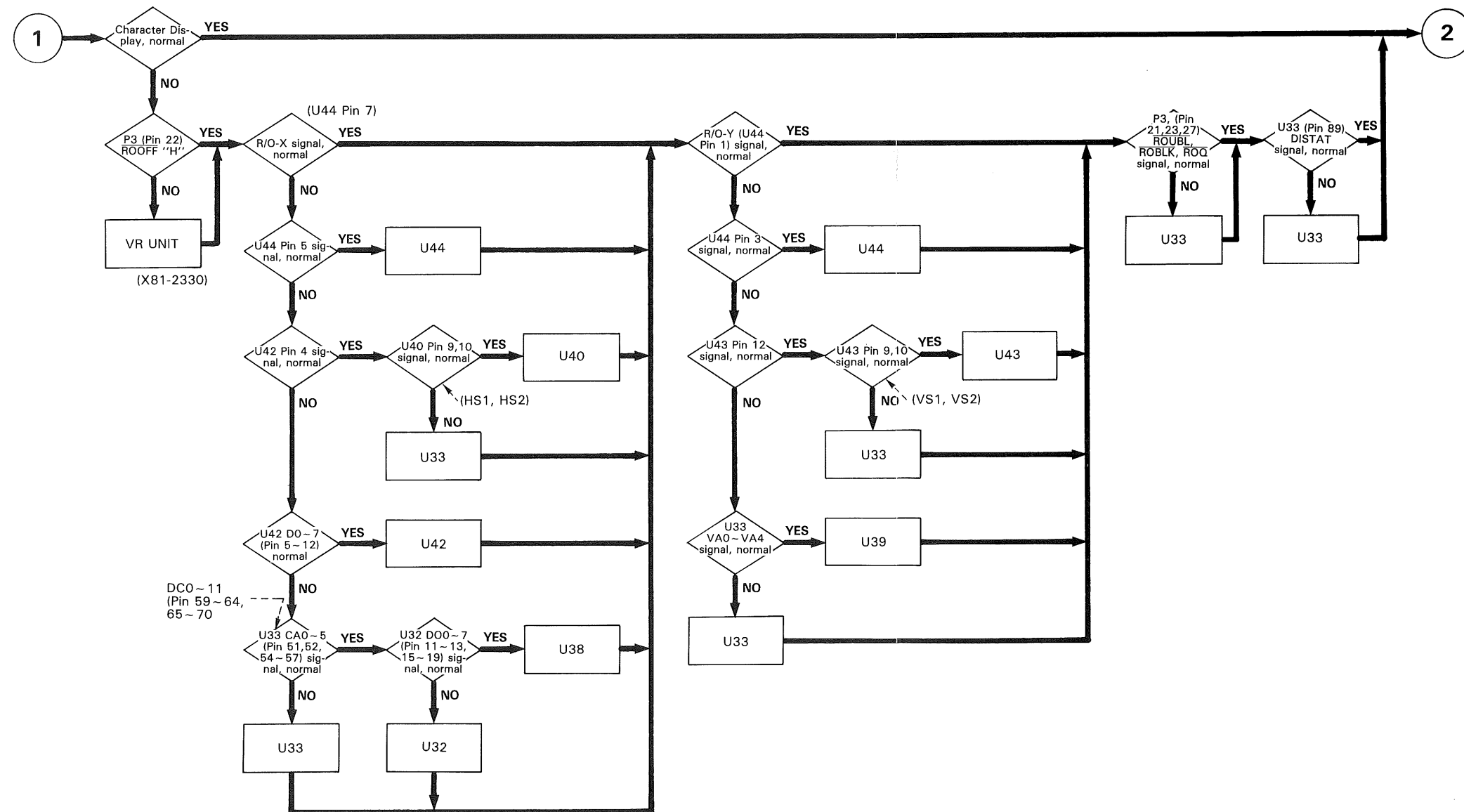
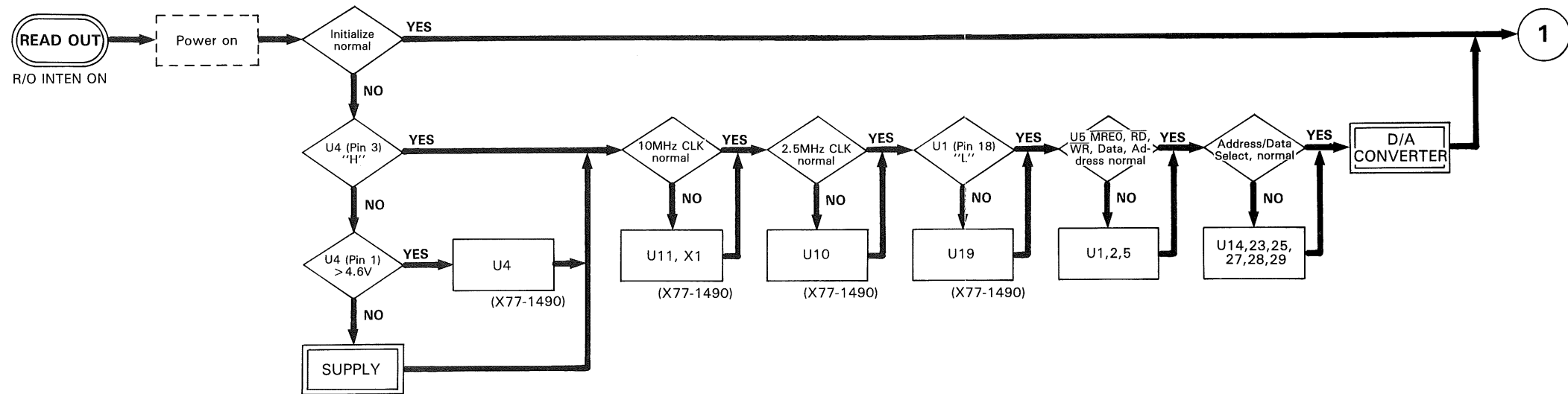

TROUBLESHOOTING

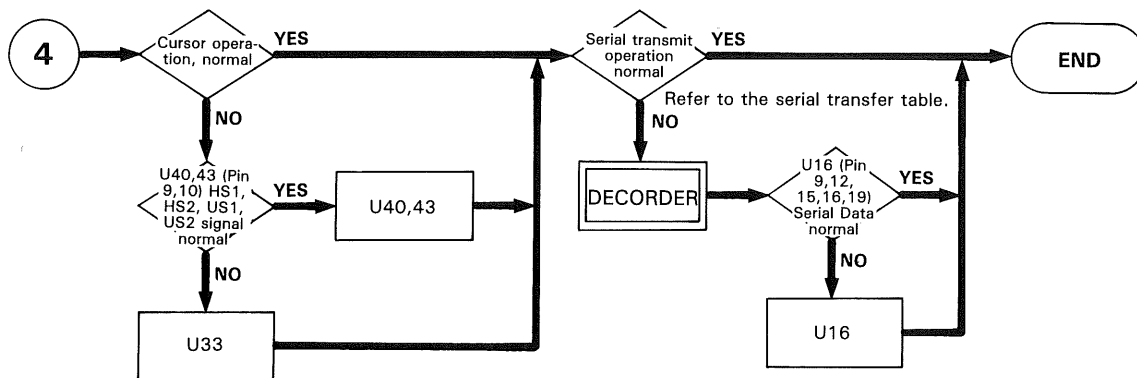
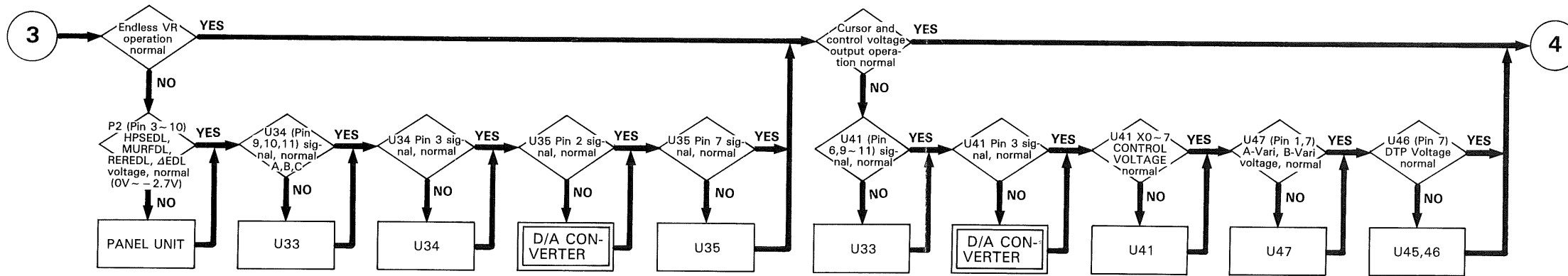
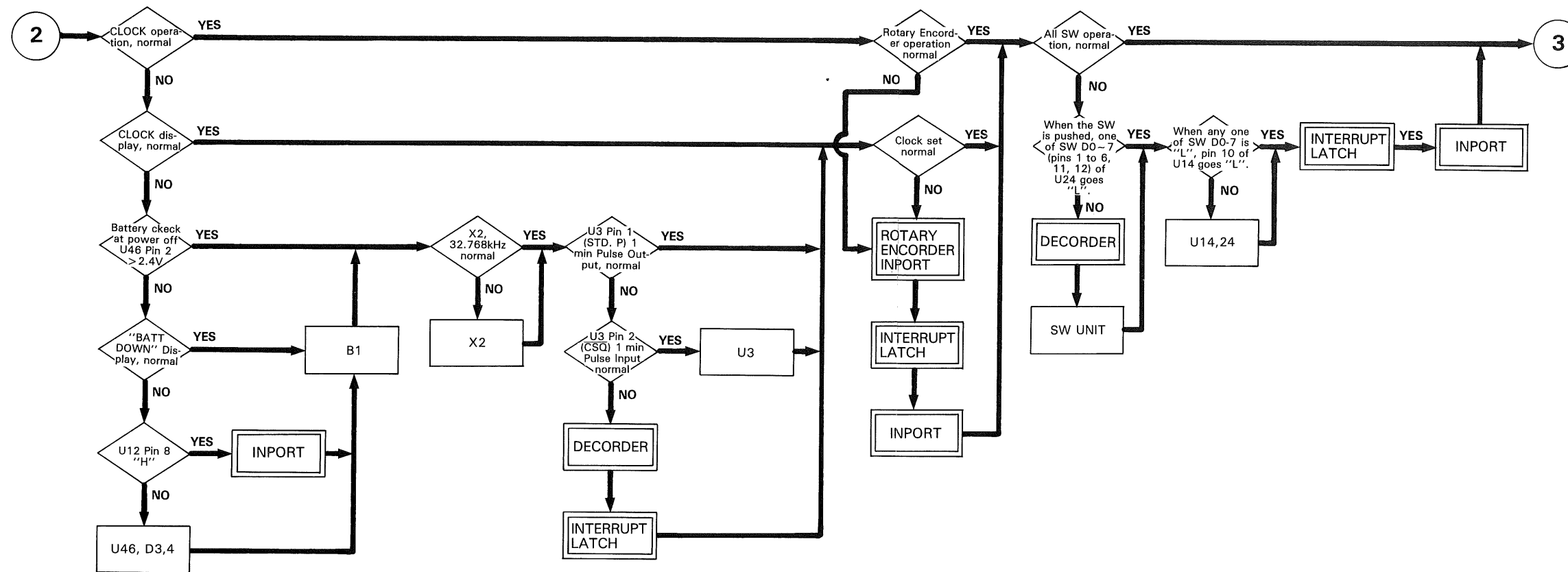

TROUBLESHOOTING

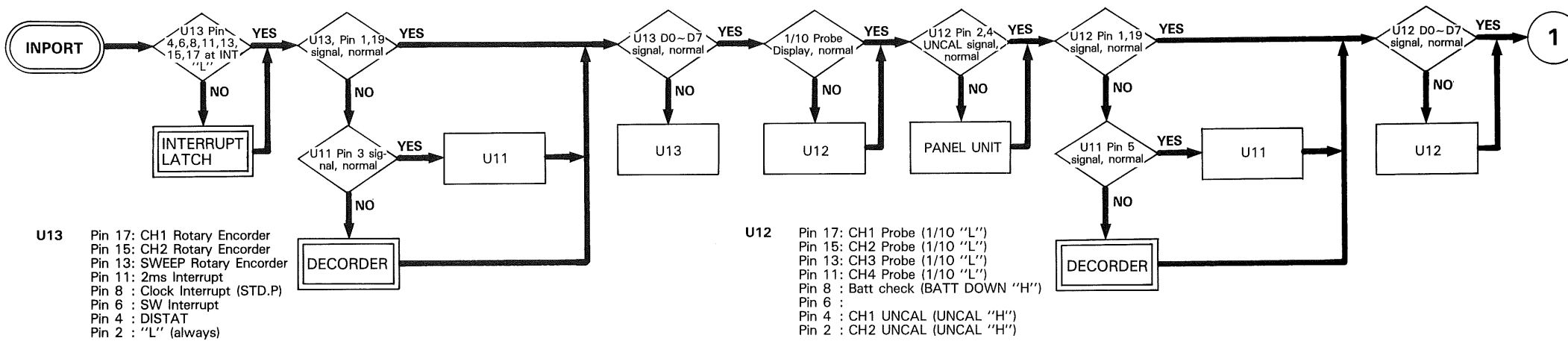
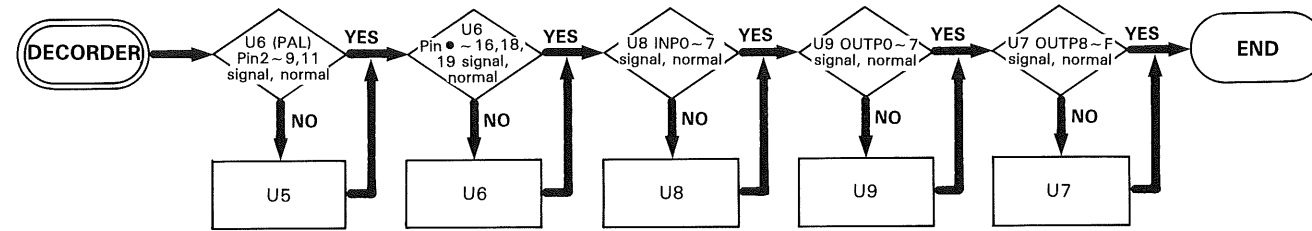
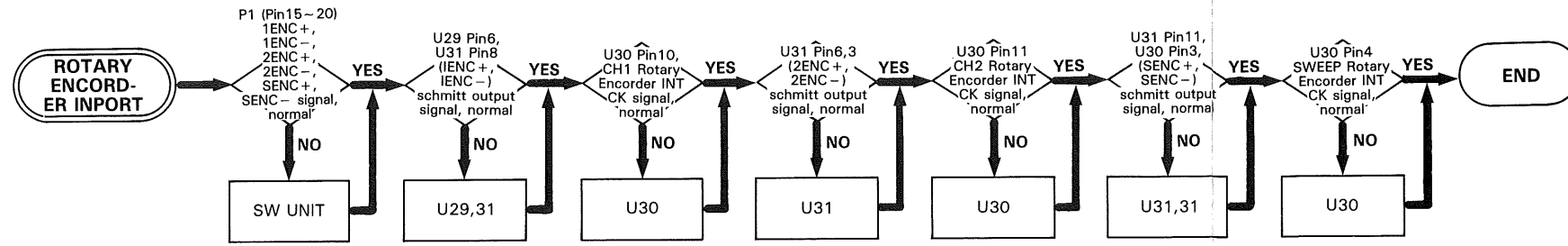

TROUBLESHOOTING

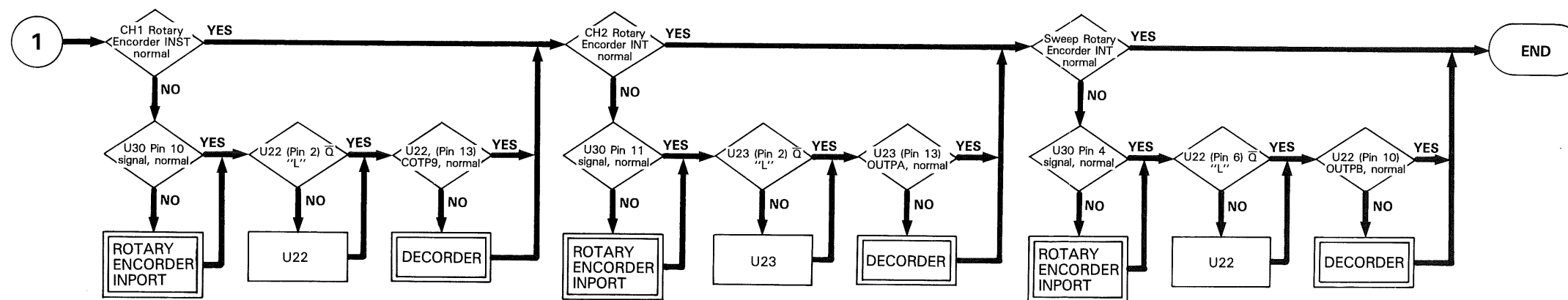
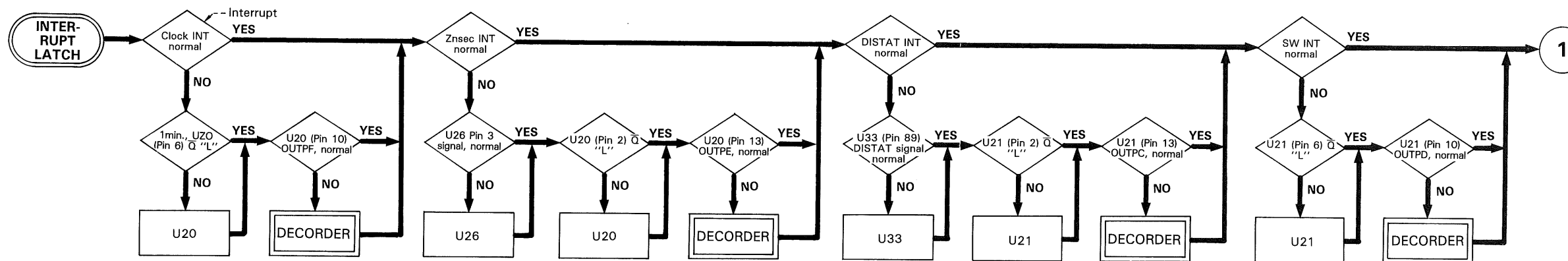
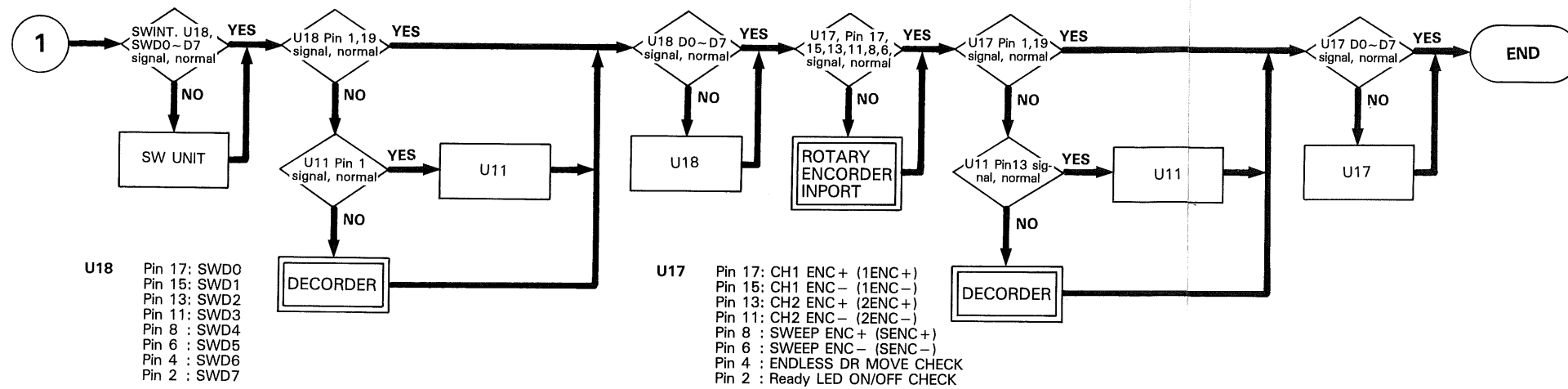

TROUBLESHOOTING

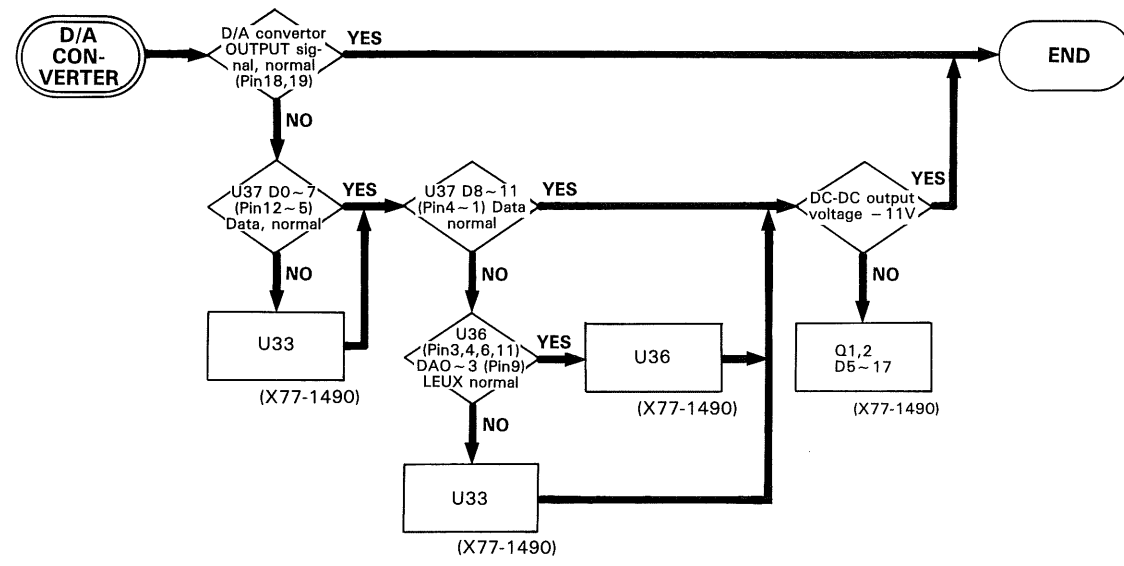

TROUBLESHOOTING

CTM5020 PIN ASSIGNMENT (100-pin FPT) (with RAM)

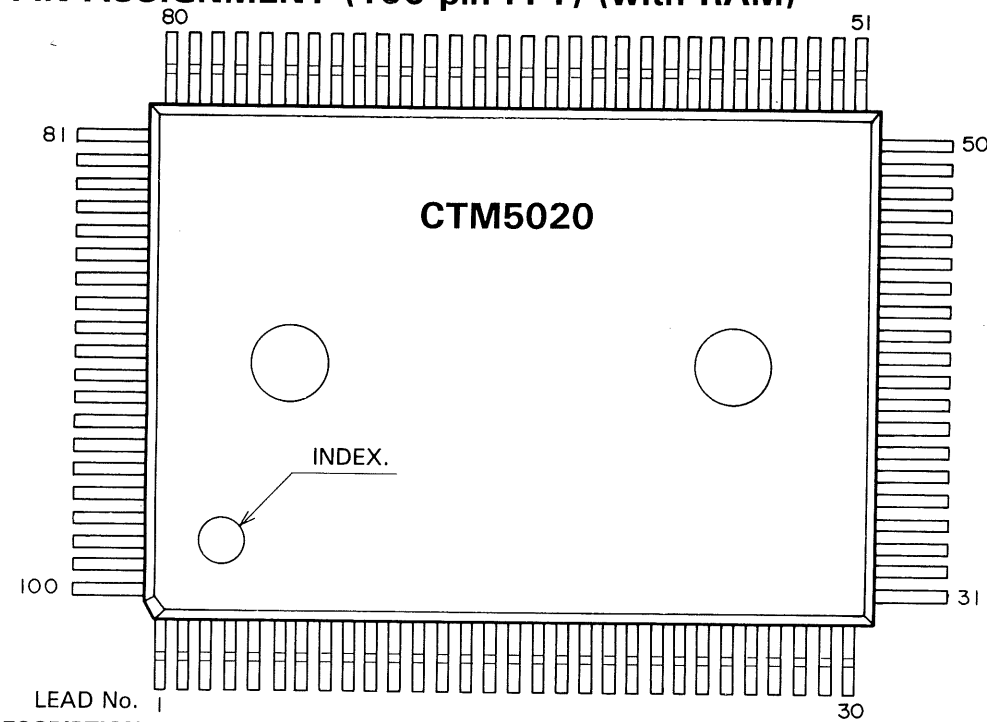

CTM5020 PIN DESCRIPTION

Pin No.	I/O	Pin Name	Function
1	I	CONT	Selection between X-Y mode and normal mode
2	I	A13	Address bus A13
3	-	VDD	+5 V power supply
4	I	A14	Address bus A14
5	I	A15	Address bus A15
6	O	INT0	1/2 period of ROSF signal (Open pin)
7	O	VX3	Selection signal of analog switch to input the endless VR voltage
8	O	VX2	Selection signal of analog switch to input the endless VR voltage
9	O	VX1	Selection signal of analog switch to input the endless VR voltage
10	O	VX0	Selection signal of analog switch to input the endless VR voltage
11	O	DA0	Output (8004H) D0 D/A data (LSB or D8)
12	O	DA1	Output (8004H) D1 D/A data (D1 or D9)
13	O	DA2	Output (8004H) D2 D/A data (D2 or D10)
14	O	DA3	Output (8004H) D3 D/A data (D3 or MSB)
15	-	VSS	GND
16	O	DA4	Output (8004H) D4 D/A data (D4)
17	O	DA5	Output (8004H) D5 D/A data (D5)
18	O	DA6	Output (8004H) D6 D/A data (D6)
19	O	DA7	Output (8004H) D7 D/A data (D7)
20	O	DA8	Output (8005H) D0 (Open pin)
21	O	DA9	Output (8005H) D1 (Serial blanking control signal)
22	O	ROR	Readout monitor terminal

Pin No.	I/O	Pin Name	Function
23	I	ROA	Readout monitor terminal
24	O	LEVX	Output (8005H) D7 D/A Data D8-MSB Latch signal
25	I	TCL	Test pin (UDD)
26	I	TSD0	Test pin (GND)
27	I	TSD1	Test pin (GND)
28	-	VDD	+5 V power supply
29	I	TSD2	Test pin (GND)
30	O	AX2	Selection signal of analog switch to output the cursor, H Variable, Delay Position, H Position voltage
31	O	AX1	Selection signal of analog switch to output the cursor H variable, Delay Position, H Position voltage
32	O	AX0	Selection signal of analog switch to output the cursor H variable, Delay Position, H position voltage
33	O	AX3	Selection signal of analog switch to output the cursor H variable, Delay Position, H Position voltage
34	O	HS2	Selection signal of analog switch for the readout X-axis signal
35	O	HS1	Selection signal of analog switch for the readout X-axis signal
36	O	TDIO	Test pin (VDD)
37	I	TWE	Test pin (VDD)
38	I	TCK1	Test pin (VDD)
39	I	TST1	Test pin (VDD)

Pin No.	I/O	Pin Name	Function
40	-	VSS	GND
41	I	TST2	Test pin (VDD)
42	I	TADD	Test pin (VDD)
43	I	TCK2	Test pin (VDD)
44	O	VS2	Selection signal of analog switch for the readout Y-axis signal
45	O	VS1	Selection signal of analog switch for the readout Y-axis signal
46	O	VA0	Character Y-axis DAC data
47	O	VA4	Character Y-axis DAC data
48	O	VA3	Character Y-axis DAC data
49	O	VA2	Character Y-axis DAC data
50	O	VA1	Character Y-axis DAC data
51	O	GETD	Character X-axis data latch clock
52	O	CA0	Character counter data
53	-	VDD	+5 V power supply
54	O	CA4	Character counter data
55	O	CA3	Character counter data
56	O	CA2	Character counter data
57	O	CA1	Character counter data
58	O	CD3	Character ROM address
59	O	CD2	Character ROM address
60	O	CD4	Character ROM address
61	O	CD1	Character ROM address
62	O	CD5	Character ROM address
63	O	DC4	Dot counter data
64	O	CD7	Character ROM address
65	-	VSS	GND
66	O	DC3	Dot counter data
67	O	DC2	Dot counter data
68	O	CD6	Character ROM address
69	O	DC1	Dot counter data

Pin No.	I/O	Pin Name	Function
70	O	DC0	Dot counter data
71	O	CD0	Character ROM address (Open pin)
72	I	DO7	Character ROM Y-axis DAC data
73	I	DO6	Character ROM Y-axis DAC data
74	I	DO5	Character ROM Y-axis DAC data
75	I	DO4	Character ROM Y-axis DAC data
76	I	DO3	Character ROM Y-axis DAC data
77	I	SING	Terminal for SINGLE signal
78	-	VDD	+5 V power supply
79	I	R10M	10 MHz clock
80	I	10M	10 MHz clock
81	I	HLDF	Holdoff input
82	I	SGA	Sweep gate
83	I	ROSP	Readout off
84	I	ROD	Character counter reset
85	O	HLDL	Holdoff output
86	O	ROUB	Readout unblanking
87	O	ROB	Readout blanking
88	O	ROQ	Readout request
89	O	ROED	Readout end
90	-	VSS	GND
91	I	D7	Data bus D7
92	I	D5	Data bus D5
93	I	D3	Data bus D3
94	I	D1	Data bus D1
95	I	ALE	Address/Data latch
96	I	D6	Data bus D6
97	I	D4	Data bus D4
98	I	D2	Data bus D2
99	I	D0	Data bus D0
100	I	WR	Write timing signal

TROUBLESHOOTING

Rotary Encoder Timing chart (X77-1490-00)

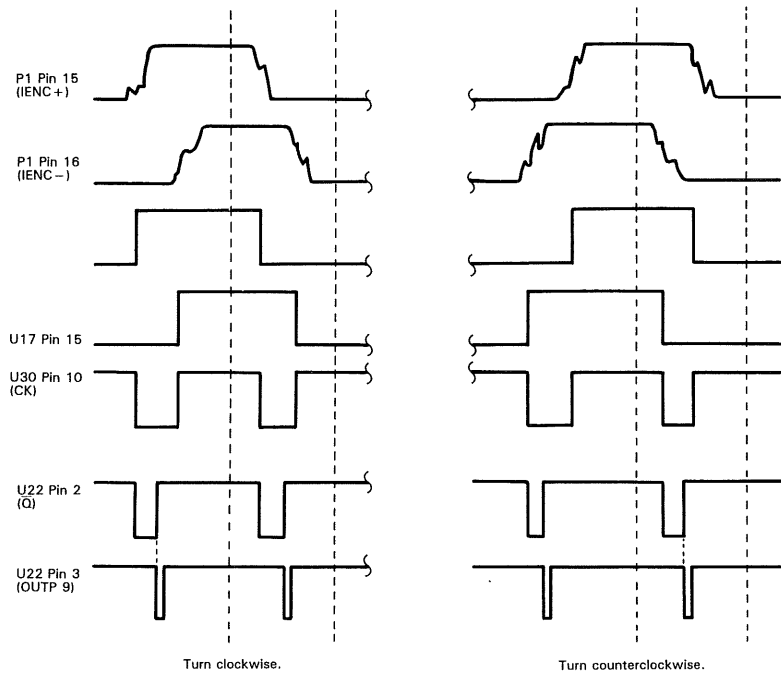

The timing charts of the CH2 rotary encoder and sweep rotary encoder are also the same.

Address/Data Select Timing Chart (X77-1490-00)

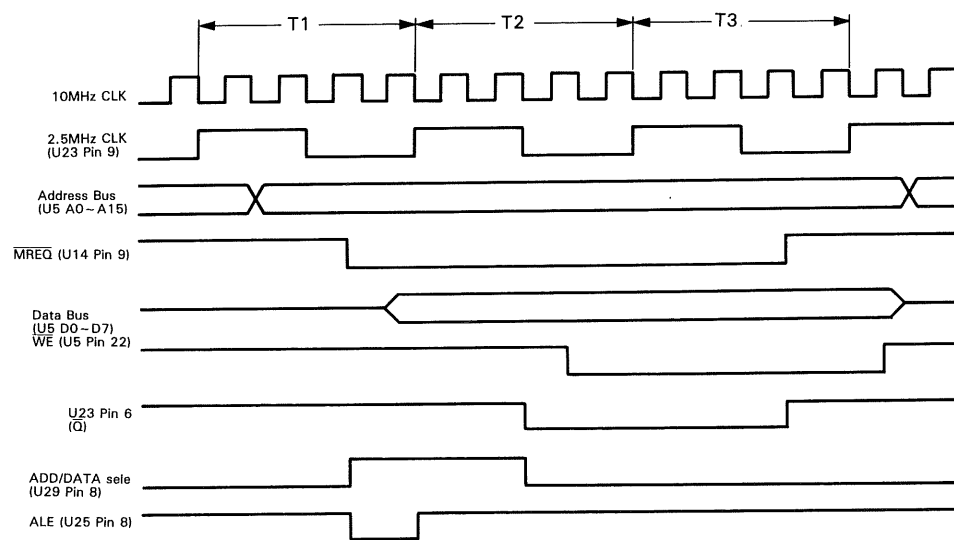

Interrupt Timing Chart

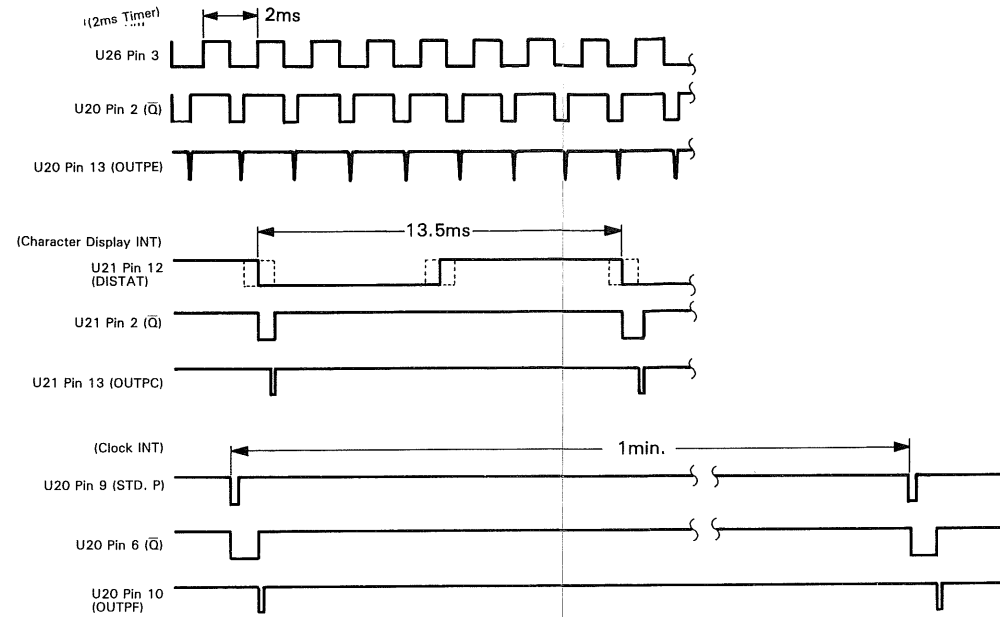

Serial Transmit Timing Chart

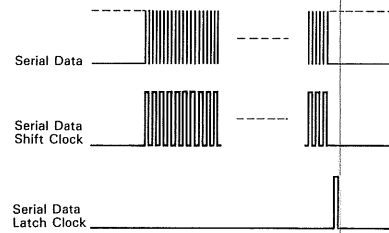

	Panel SW SCAN	Panel LED Control	ATT UNIT Control	V UNIT Control	H UNIT Control
Serial Data	P1 Pin 4 (SD)	P1 Pin 1 (LD)	P4 Pin 9 (AD)	U16 Pin 16 (VD)	U16 Pin 19 (HD)
Serial Data shift Clock	P1 Pin 5 (SSC)	P1 Pin 2 (LSC)	P4 Pin 8 (ASC)	U9 Pin 14 (VSC)	U9 Pin 10 (HSC)
Serial Data Latch clock	P1 Pin 6 (SLC)	P1 Pin 3 (LLC)	P4 Pin 7 (ALC)	U8 Pin 11 (VLC)	U8 Pin 7 (HLC)

CH1 (CH2) Vertical Gain VARIABLE

V. Variable	U12 Pin 4 (2)	Display
CAL	L	Space
UNCAL	H	>

CH1 ~ CH4 Probe

Probe	U12 Pin 17,15,13,11	Display
1/1	H	Vdts/div x 1 display
1/10	L	Vots/div x 10 display

Endless VR Select and Control Timing Chart

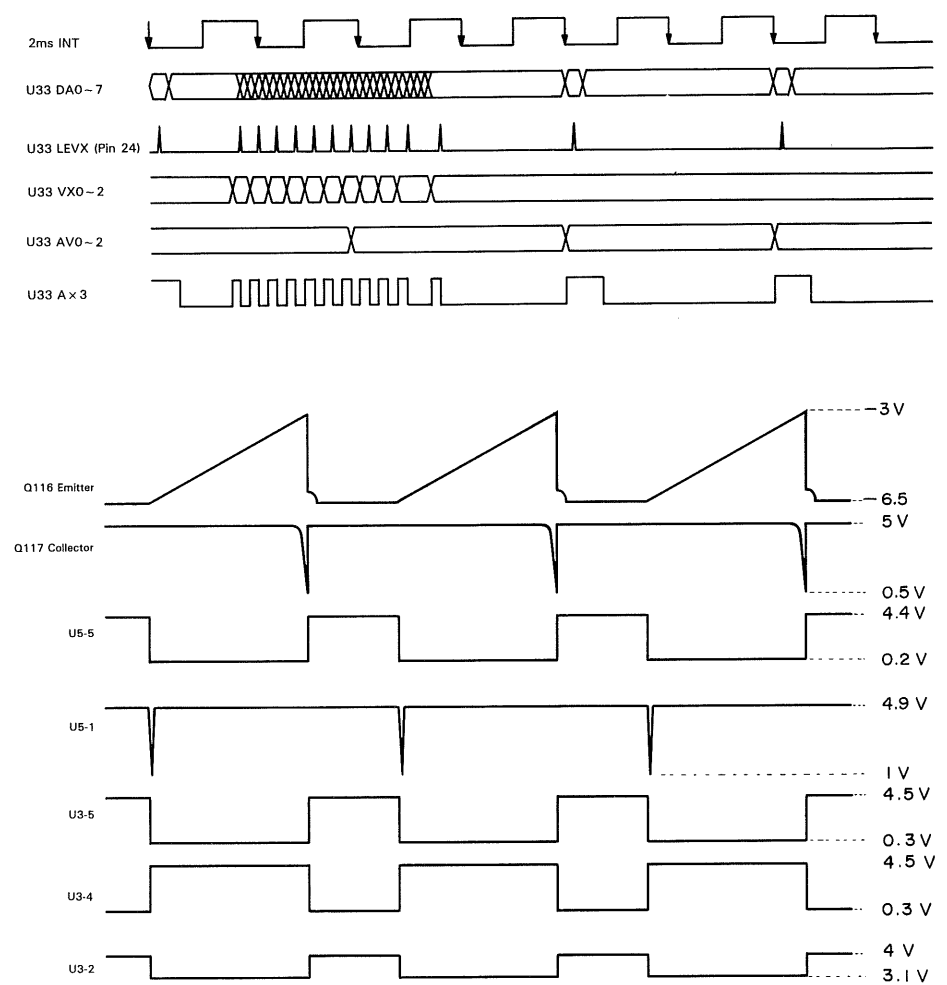

Endless VR Select

V x 2	V x 1	V x 0	Select CH	Endless VR
L	L	L	U34 Pin 13	Δ Endless VR
L	L	H	U34 Pin 14	
L	H	L	U34 Pin 15	
L	H	H	U34 Pin 12	REF Endless VR
H	L	L	U34 Pin 1	H-Posi Endless VR
H	L	H	U34 Pin 5	
H	H	L	U34 Pin 2	H-Vari Endless VR
H	H	H	U34 Pin 4	

CONTROL Voltage Select

A x 3	A x 2	A x 1	A x 0	Select CH	Control Voltage
L	L	L	L	U41 Pin 13	REF Cursor
L	L	L	H	U41 Pin 14	Δ Cursor
L	L	H	L	U41 Pin 15	A-Variable
L	L	H	H	U41 Pin 12	B-Variable
L	H	L	L	U41 Pin 1	V-Delay } (DTP)
L	H	L	H	U41 Pin 5	
L	H	H	L	U41 Pin 2	
L	H	H	H	U41 Pin 4*	H-Posi
H	X	X	X	All off	Inhibit

* Items marked * are not selected.
X Items marked X can be either L or H.

PARTS LIST

CS-6010 UNIT

Y70-1630-01

REF. NO	PARTS NO	NAME & DESCRIPTION
	B07-0703-04	ESCUTCHEON FOR ASTIG
	B30-0925-05	LAMP
	B50-7670-10	INSTRUCTION MANUAL, JAPANESE
	B50-7671-10	INSTRUCTION MANUAL, ENGLISH
	E30-1644-15	BS POWER CORD
	E30-1818-05	JIS POWER CORD
	E30-1819-05	CEE POWER CORD
	E30-1820-05	UL/CSA POWER CORD
	E30-1821-05	SAA POWER CORD
	E31-0717-05	WIRE ASS'Y(INLET TO GND)
	E31-5561-05	WIRE ASS'Y(NO.22)
	E31-5562-05	WIRE ASS'Y(NO.30)
	E31-5563-05	WIRE ASS'Y(NO.7,8,9)
	E31-5564-05	WIRE ASS'Y(NO.25)
	E31-5565-05	WIRE ASS'Y(NO.26)
	E31-5566-05	WIRE ASS'Y(CAL)
	E31-5567-05	WIRE ASS'Y(NO.4)
	F05-1224-05	FUSE 1.2A(6X30MM) FOR 100/120V
	F05-8013-05	FUSE 0.8A(5X20MM) FOR 220/240V
	F05-8015-05	FUSE 0.8A(6X30MM) FOR 220/240V
	F15-0733-04	FELT (CRT SHIELD)
	F20-0674-04	INSULATED SHEET, HIGH VOLTAGE
	H01-5894-04	CARTON BOX
	H10-2901-02	FOAMED STYRENE PAD, FRONT
	H10-2902-02	FOAMED STYRENE PAD, REAR
	H20-1727-04	VINYL COVER
	W03-2301-15	R/O PROBE, PC-31
C1	CC45CH2H330J	CAP. CERAMIC 33P 5% 500V
R1	R014BB2C471J	RES. CARBON 470 5% 1/6W
1	A01-1194-12	CASE, TOP
2	A01-1195-32	CASE, BOTTOM
3	A13-0924-12	FRAME, RIGHT
4	A13-0933-22	FRAME, CENTER
5	A13-0934-12	FRAME, LEFT
6	A13-0927-03	FRAME, P.C.B SUPPORT
7	A13-0928-03	FRAME
8	A13-0929-03	FRAME
9	A20-2826-11	MOLDED PANEL
10	A20-2827-12	MOLDED PANEL
11	A21-1143-03	DECORATIVE PANEL
12	A21-1136-03	DECORATIVE PANEL
13	A23-1683-12	REAR PANEL
14	B11-0504-14	FILTER
15	B30-0963-05	LAMP ASS'Y, SCALE ILLUMINATION
16	B40-2918-03	NAME PLATE, MODEL
17	B41-0807-04	CAUTION LABEL, REAR PANEL
18	D19-0505-05	FLEXIBLE WIRE, FOR POWER SWITCH
19	G53-0015-14	BUSHING
20	E04-0259-05	BNC RECEPTACLE
21A	E18-0365-05	AC SELECTOR WITH 6X30MM FUSE
21B	E18-0366-05	AC SELECTOR WITH 5X20MM FUSE
22	E21-0660-04	TERMINAL, CAL
23	E21-0667-05	METAL TERMINAL
24	E23-0513-05	EARTH LUG, BNC
25	E31-5568-05	FLAT CABLE
26	E31-5569-05	FLAT CABLE
27	F07-0936-04	COVER, HANDLE LATCH
28	F10-1604-04	SHIELD, R/O UNIT
29	F10-1605-03	SHIELD, R/O UNIT
30	F10-1606-03	SHIELD, HIGH VOLTAGE UNIT
31	F11-1212-12	SHIELD, CRT: FRONT
32	F11-1210-03	SHIELD, CRT: REAR
33	F20-0673-04	INSULATED SHEET
34	G02-0606-14	SPRING, FOR HANDLE
35	J02-0089-05	RUBBER FOOT
36	J11-0508-05	CABLE CLAMP
37	J19-1656-03	HOLDER, COIL
38	J19-1657-04	WEDGE
39	J21-2906-05	GEAR, FOR HANDLE
40	J21-2907-05	RING, FOR HANDLE
41	J21-4642-04	BRACKET
42	J21-4613-04	BRACKET
43	J32-0887-04	BOSS, FOR POWER SWITCH
44	J61-0516-05	SUPPORT
45	J61-0521-05	SUPPORT
46	K01-0528-05	HANDLE, CARRYING
47	K21-0898-03	KNOB, VOLT/DIV, SWEEP TIME/DIV
48	K23-0808-03	KNOB (18 USED)
49	K27-0504-04	KNOB, PUSH: POWER
50	K27-0543-04	KNOB, PUSH (34 USED)
51	L01-9766-05	POWER TRANSFORMER
52	L39-0527-05	COIL, TRACE ROTATION
53	L76-0115-05	DELAY LINE
54	S40-1524-05	PUSH SWITCH, POWER
55	W01-0503-04	REAR RUBBER FOOT/CORD WRAP
56	X66-1050-00	PANEL UNIT

REF. NO	PARTS NO	NAME & DESCRIPTION
57	X68-1500-00	POWER SUPPLY UNIT
58	X68-1510-01	HIGH VOLTAGE UNIT
59	X69-1150-01	SWITCH UNIT
60	X73-1760-00	VERTICAL PREAMP UNIT
61	X74-1480-01	HORIZONTAL UNIT
62	X75-1180-00	ATT. UNIT
63	X77-1490-00	R/O UNIT
64	X77-1500-00	CONNECTION UNIT
65	X80-1100-01	FINAL UNIT
66	X81-2330-01	VR UNIT
67	150YTM31	CRT
68	J59-0403-05	NYLON RIVET (ILLUMI)
69	N19-0710-05	WASHER
70	J19-1660-05	SUPPORT, FOR PCB

MODEL PC-31 (LOW CAPACITY PROBE)

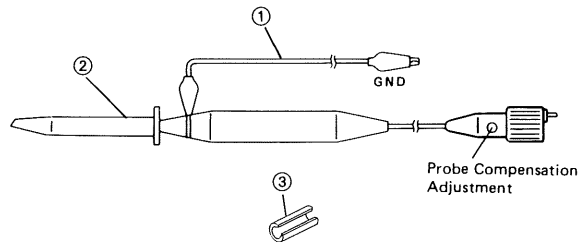

ITEM	DESCRIPTION	PARTS NO.
①	Ground Wire Assembly	E30-1883-08
②	Retractable Hook Tip	E29-0540-08
③	Marker (Orange)	B42-1950-08

PARTS LIST

PANEL UNIT

X66-1050-00

REF. NO	PARTS NO	NAME & DESCRIPTION
	J25-5197-03	PCB (UNMOUNTED)
	J61-0521-05	SUPPORT
45	C001	CAP. CERAMIC 1000P 10% 500V
	C002	CAP. CERAMIC 1000P 10% 500V
	C003	CAP. CERAMIC 1000P 10% 500V
	C004	CAP. CERAMIC 1000P 10% 500V
	C005	CAP. CERAMIC 1000P 10% 500V
	C006	CAP. CERAMIC 1000P 10% 500V
	C007	CAP. CERAMIC 1000P 10% 500V
	C008	CAP. CERAMIC 1000P 10% 500V
D001	MA700	DIODE
D002	MA700	DIODE
J031	E31-5555-05	LEAD WIRE WITH CONNECTOR
J100	R92-0150-05	JUMPING RES. ZERO OHM(10MM)
J101	R92-0150-05	JUMPING RES. ZERO OHM(10MM)
P002	E40-7038-05	PIN CONNECTOR 26P
0001	2SC2785(F)	TR. SI, NPN
0002	2SA1175(F)	TR. SI, PNP
0003	2SC2785(F)	TR. SI, NPN
0004	2SA1175(F)	TR. SI, PNP
R001	RN14BK2C2202F	RES. METAL FILM 22K 1% 1/6W
R002	RN14BK2C9103F	RES. METAL FILM 910K 1% 1/6W
R003	RN14BK2C9103F	RES. METAL FILM 910K 1% 1/6W
R004	RD14BB2C472J	RES. CARBON 4.7K 5% 1/6W
R005	RD14BB2C472J	RES. CARBON 4.7K 5% 1/6W
R006	RD14BB2C222J	RES. CARBON 2.2K 5% 1/6W
R007	RN14BK2C2202F	RES. METAL FILM 22K 1% 1/6W
R008	RN14BK2C9103F	RES. METAL FILM 910K 1% 1/6W
R009	RN14BK2C9103F	RES. METAL FILM 910K 1% 1/6W
R010	RD14BB2C472J	RES. CARBON 4.7K 5% 1/6W
R011	RD14BB2C472J	RES. CARBON 4.7K 5% 1/6W
R012	RD14BB2C222J	RES. CARBON 2.2K 5% 1/6W
R013	RN14BK2C6801F	RES. METAL FILM 6.8K 1% 1/6W
R014	RN14BK2C1802F	RES. METAL FILM 18K 1% 1/6W
R015	RD14BB2E220J	RES. CARBON 22 5% 1/4W
U001	NJM4558D	IC, DUAL OP AMP
VR001	R05-3514-05	VOLUME 20K B
VR002	R05-3514-05	VOLUME 20K B
VR003	R05-3514-05	VOLUME 20K B
VR004	R05-3514-05	VOLUME 20K B
VR005	R05-3514-05	VOLUME 20K B
VR006	R05-3514-05	VOLUME 20K B
VR007	R05-3514-05	VOLUME 20K B
VR008	R05-3514-05	VOLUME 20K B
VR009	R05-3514-05	VOLUME 20K B
VR010	R05-3514-05	VOLUME 20K B
VR011	R10-3504-05	ENDLESS VOLUME 2X10K B
VR012	R10-3504-05	ENDLESS VOLUME 2X10K B
VR013	R10-3504-05	ENDLESS VOLUME 2X10K B
VR014	R10-3504-05	ENDLESS VOLUME 2X10K B

POWER SUPPLY UNIT

X68-1500-00

REF. NO	PARTS NO	NAME & DESCRIPTION
	J25-5227-03	PCB (UNMOUNTED)
	N14-0626-04	NUT
	N30-3008-41	SCREW, PAN HD M3X8
73	F01-0865-14	HEAT SINK
C001	CE04W2E4R7M	CAP. ELECTRO 4.7 20% 250V
C002	CE04EW2A220M	CAP. ELECTRO 22 20% 100V
C003	CE04EW1C331M	CAP. ELECTRO 330 20% 16V
C004	CE04EW1C331M	CAP. ELECTRO 330 20% 16V
C005	CE04EW1E101M	CAP. ELECTRO 100 20% 25V
C006	CE04EW1A102M	CAP. ELECTRO 1000 20% 10V
C007	CE04W2E470M	CAP. ELECTRO 47 20% 250V
C008	CE04EW2A471M	CAP. ELECTRO 470 20% 100V
C009	C90-0973-05	CAP. ELECTRO 6800 20% 25V
C010	C90-0973-05	CAP. ELECTRO 6800 20% 25V
C011	C90-0982-05	CAP. ELECTRO 10000 20% 16V
C012	CE04HW1H010M	CAP. ELECTRO 1 20% 50V
C013	CE04EW1H331M	CAP. ELECTRO 330 20% 50V
C014	CE04EW1V471M	CAP. ELECTRO 470 20% 35V
C015	CE04EW1E101M	CAP. ELECTRO 100 20% 25V

REF. NO	PARTS NO	NAME & DESCRIPTION
C016	CK45FF1H103Z	CAP. CERAMIC 0.01
C017	CE04HW1H010M	CAP. ELECTRO 1 20% 50V
C018	CC45FCH1H470J	CAP. CERAMIC 47P 5% 50V
C019	CC45FCH1H470J	CAP. CERAMIC 47P 5% 50V
D001	1SS132	DIODE
D002	1SS132	DIODE
D003	MT213JB	DIODE, ZENER 12.88V
D004	MT213JB	DIODE, ZENER 12.88V
D005	MT25.1JB	DIODE, ZENER 5.07V
D006	S1VB60	DIODE
D007	S1VB60	DIODE
D008	S4VB40F	DIODE, BRIDGE
D009	S4VB40F	DIODE, BRIDGE
D010	1SR35-200A	DIODE
D011	1SR35-200A	DIODE
D012	MT224JC	DIODE, ZENER 23.72V
D013	MT27.5JA	DIODE, ZENER 7.04V
P017	E40-1173-05	PIN CONNECTOR 11P
P018	E40-7040-05	PIN CONNECTOR 13P
Q001	2SD1409	TR. SI, NPN
Q002	2SC2271(D)	TR. SI, NPN
Q003	2SD1409	TR. SI, NPN
Q004	2SC2271(D)	TR. SI, NPN
Q005	2SB1133(S)	TR. SI, PNP
Q006	2SD1666(S)	TR. SI, NPN
Q007	2SB1133(S)	TR. SI, PNP
Q008	2SA684(D)	TR. SI, PNP
R001	RN14BK2C1302F	RES. METAL FILM 13K 1% 1/6W
R002	RN14BK2C1803F	RES. METAL FILM 180K 1% 1/6W
R003	RD14BB2C123J	RES. CARBON 12K 5% 1/6W
R004	RN14BK2C2002F	RES. METAL FILM 20K 1% 1/6W
R005	RN14BK2C1203F	RES. METAL FILM 120K 1% 1/6W
R006	RD14BB2C912J	RES. CARBON 9.1K 5% 1/6W
R007	RN14BK2C2002F	RES. METAL FILM 20K 1% 1/6W
R008	RN14BK2C2002F	RES. METAL FILM 20K 1% 1/6W
R009	RD14BB2C103J	RES. CARBON 10K 5% 1/6W
R010	RD14BB2C472J	RES. CARBON 4.7K 5% 1/6W
R011	RD14BB2C102J	RES. CARBON 1K 5% 1/6W
R012	RD14BB2C472J	RES. CARBON 4.7K 5% 1/6W
R013	RD14BB2C512J	RES. CARBON 5.1K 5% 1/6W
R014	RN14BK2C1002F	RES. METAL FILM 10K 1% 1/6W
R015	RN14BK2C2002F	RES. METAL FILM 20K 1% 1/6W
R016	RD14BB2C102J	RES. CARBON 1K 5% 1/6W
R017	RD14BB2C102J	RES. CARBON 1K 5% 1/6W
R018	RD14BB2C102J	RES. CARBON 1K 5% 1/6W
R019	RD14BB2C102J	RES. CARBON 1K 5% 1/6W
R020	RD14BB2C221J	RES. CARBON 220 5% 1/6W
R021	RD14BB2C221J	RES. CARBON 220 5% 1/6W
R022	NO USE	
R023	RD14BB2C362J	RES. CARBON 3.6K 5% 1/6W
R024	RD14BB2C163J	RES. CARBON 16K 5% 1/6W
R025	R92-1402-05	RES. SPECIAL POWER 24 5% 2W
R026	NO USE	
R027	R92-1402-05	RES. SPECIAL POWER 24 5% 2W
R028	RD14BB2C333J	RES. CARBON 33K 5% 1/6W
R029	RD14BB2C221J	RES. CARBON 220 5% 1/6W
R030	RD14BB2C622J	RES. CARBON 6.2K 5% 1/6W
R031	R92-1421-05	RES. SPECIAL POWER 7.5 5% 3W
R032	RN14BK2C1502F	RES. METAL FILM 15K 1% 1/6W
R033	RN14BK2C1002F	RES. METAL FILM 10K 1% 1/6W
R034	RD14BB2C622J	RES. CARBON 6.2K 5% 1/6W
R035	RD14BB2C102J	RES. CARBON 1K 5% 1/6W
R036	RD14BB2C102J	RES. CARBON 1K 5% 1/6W
U001	NJM4556S	IC, DUAL OP AMP
U002	NJM4556S	IC, DUAL OP AMP
U003	NJM4556S	IC, DUAL OP AMP
VR001	R12-1551-05	RES. SEMI FIXED 1KB

PARTS LIST

HIGH VOLTAGE UNIT

X68-1510-01

REF. NO	PARTS NO	NAME & DESCRIPTION			
	F01-0813-05	HEAT SINK (CONVERTER)			
	F10-1601-04	SHIELD PLATE			
	F15-0727-04	HOLDER (NEON LAMP)			
	J25-5226-03	PCB (UNMOUNTED)			
	N30-3006-41	SCREW, PAN HD	M3X6		
	W02-0458-05	HIGH VOLTAGE UNIT			
C001	CE04EW1E221M	CAP. ELECTRO	220	20%	25V
C002	CE04EW1E221M	CAP. ELECTRO	220	20%	25V
C003	CK45B1H472K	CAP. CERAMIC	4700P	10%	50V
C004	CK45FB1H222K	CAP. CERAMIC	2200P	10%	50V
C005	CK45SL2H101J	CAP. CERAMIC	100P	5%	500V
C006	C91-1274-05	CAP. CERAMIC	2700P	10%	3.15K
C007	C91-1274-05	CAP. CERAMIC	2700P	10%	3.15K
C008	C91-1274-05	CAP. CERAMIC	2700P	10%	3.15K
C009	CK45B2H102K	CAP. CERAMIC	1000P	10%	500V
C010	CF92V1H224J	CAP. POLYESTER	0.22	5%	50V
C011	CF92V1H224J	CAP. POLYESTER	0.22	5%	50V
C012	CK45E3F102P	CAP. CERAMIC	1000P		3.1K
C013	C91-1274-05	CAP. CERAMIC	2700P	10%	3.15K
C014	C91-1274-05	CAP. CERAMIC	2700P	10%	3.15K
C015	C91-1274-05	CAP. CERAMIC	2700P	10%	3.15K
C016	C91-1274-05	CAP. CERAMIC	2700P	10%	3.15K
C017	C91-1274-05	CAP. CERAMIC	2700P	10%	3.15K
C018	CK45B2H102K	CAP. CERAMIC	1000P	10%	500V
C019	CE04HW1H010M	CAP. ELECTRO	1	20%	50V
C020	CK45FB2H472K	CAP. CERAMIC	4700P	10%	500V
C021	CC45CH2H010C	CAP. CERAMIC	1P	0.25P	500V
C022	CC45CH2H010C	CAP. CERAMIC	1P	0.25P	500V
C023	CK45F1H103Z	CAP. CERAMIC	0.01		50V
C024	CC45CH2H020C	CAP. CERAMIC	2P	0.25P	500V
C025	CC45CH2H010C	CAP. CERAMIC	1P	0.25P	500V
C026	CE04HW1H010M	CAP. ELECTRO	1	20%	50V
C027	CK45FB2H472K	CAP. CERAMIC	4700P	10%	500V
C031	C91-1274-05	CAP. CERAMIC	2700P	10%	3.15K
C032	C91-1274-05	CAP. CERAMIC	2700P	10%	3.15K
C033	C91-1274-05	CAP. CERAMIC	2700P	10%	3.15K
C034	C91-1274-05	CAP. CERAMIC	2700P	10%	3.15K
C035	CE04W2C2R2M	CAP. ELECTRO	2.2	20%	160V
C036	CE04W2C2R2M	CAP. ELECTRO	2.2	20%	160V
C037	CK45FB2H472K	CAP. CERAMIC	4700P	10%	500V
C038	CE04EW1C101M	CAP. ELECTRO	100	20%	16V
C039	CE04EW1C101M	CAP. ELECTRO	100	20%	16V
C040	CE04EW1C101M	CAP. ELECTRO	100	20%	16V
C043	CE04EW0J102M	CAP. ELECTRO	1000	20%	6.3V
C044	CK45FB2H472K	CAP. CERAMIC	4700P	10%	500V
D001	1SS132	DIODE			
D002	1SS132	DIODE			
D003	1SS132	DIODE			
D004	1SR35-200A	DIODE			
D005	1SR35-200A	DIODE			
D006	1SS83	DIODE			
D007	1SS83	DIODE			
D008	1SR35-200A	DIODE			
D009	1SR35-200A	DIODE			
D010	1SS83	DIODE			
D011	1SS132	DIODE			
D012	1SS132	DIODE			
D013	1SS83	DIODE			
L001	L40-3925-04	FERRI INDUCTOR	3.9MH		
L002	L40-1011-04	FERRI INDUCTOR	100UH		
L003	L40-1011-04	FERRI INDUCTOR	100UH		
L004	L40-1545-06	FERRI INDUCTOR	150MH		
NL001	NE-2B	NEON LAMP			
NL002	NE-2B	NEON LAMP			
NL003	NE-2B	NEON LAMP			
NL004	NE-2B	NEON LAMP			
P019	E40-1273-05	PIN CONNECTOR	12P		
P022	E40-0273-05	PIN CONNECTOR	2P		
P023	E40-0503-05	PIN CONNECTOR	5P		
P024	E40-0373-05	PIN CONNECTOR	3P		
P025	E40-0473-05	PIN CONNECTOR	4P		
P026	E40-1073-05	PIN CONNECTOR	10P		
Q001	2SD613(E)	TR. SI, NPN			
Q002	2SA1175(F)	TR. SI, PNP			
Q003	2SA1208(S,T)	TR. SI, PNP			
Q004	2SC2910(S,T)	TR. SI, NPN			
Q005	2SA1209(S,T)	TR. SI, PNP			
Q006	2SC2911(S,T)	TR. SI, NPN			

REF. NO	PARTS NO	NAME & DESCRIPTION			
0007	2SA1175(F)	TR. SI, PNP			
0008	2SC3315(C)	TR. SI, NPN			
R001	RD14BB2C821J	RES. CARBON	820	5%	1/6W
R002	RD14BB2C562J	RES. CARBON	5.6K	5%	1/6W
R003	RD14BB2C102J	RES. CARBON	1K	5%	1/6W
R004	RD14BB2C104J	RES. CARBON	100K	5%	1/6W
R005	RD14BB2C222J	RES. CARBON	2.2K	5%	1/6W
R006	RD14BB2C473J	RES. CARBON	47K	5%	1/6W
R007	R92-1127-05	RES. FIXED	8.2M	1%	1W
R008	R92-1125-05	RES. METAL FILM	7.5M	1%	1W
R009	RN14BK2C1003F	RES. METAL FILM	100K	1%	1/6W
R010	R92-1034-05	RES. METAL FILM	47M	5%	1/2W
R011	RD14BB2C470J	RES. CARBON	47	5%	1/6W
R012	RD14BB2C474J	RES. CARBON	470K	5%	1/6W
R013	R92-1034-05	RES. METAL FILM	47M	5%	1/2W
R014	RD14BB2C474J	RES. CARBON	470K	5%	1/6W
R015	RD14BB2C823J	RES. CARBON	82K	5%	1/6W
R016	RD14BB2C470J	RES. CARBON	47	5%	1/6W
R017	RD14BB2C753J	RES. CARBON	75K	5%	1/6W
R018	RD14BB2C114J	RES. CARBON	110K	5%	1/6W
R019	RD14BB2C822J	RES. CARBON	8.2K	5%	1/6W
R020	RD14BB2C102J	RES. CARBON	1K	5%	1/6W
R021	RD14BB2C332J	RES. CARBON	3.3K	5%	1/6W
R022	RD14BB2C134J	RES. CARBON	130K	5%	1/6W
R023	RD14BB2C332J	RES. CARBON	3.3K	5%	1/6W
R024	RD14BB2C134J	RES. CARBON	130K	5%	1/6W
R025	RD14BB2C751J	RES. CARBON	750	5%	1/6W
R026	RD14BB2C913J	RES. CARBON	91K	5%	1/6W
R027	RD14BB2C103J	RES. CARBON	10K	5%	1/6W
R028	RD14BB2C332J	RES. CARBON	3.3K	5%	1/6W
R029	RD14BB2C113J	RES. CARBON	11K	5%	1/6W
R030	RD14BB2C203J	RES. CARBON	20K	5%	1/6W
R034	R92-1422-05	RES. FIXED	3.9M	5%	1/2W
R035	R92-1422-05	RES. FIXED	3.9M	5%	1/2W
R036	RD14BB2C203J	RES. CARBON	20K	5%	1/6W
R037	RN14BK2E5103F	RES. METAL FILM	510K	1%	1/4W
R038		NO USE			
R039	RD14BB2C204J	RES. CARBON	200K	5%	1/6W
R040	RD14BB2C684J	RES. CARBON	680K	5%	1/6W
R041	RD14BB2C684J	RES. CARBON	680K	5%	1/6W
R042	RD14BB2C101J	RES. CARBON	100	5%	1/6W
R043	RD14BB2C2R2J	RES. CARBON	2.2	5%	1/6W
R044	R92-1026-05	RES. METAL FILM	3.3M		
R045	RD14BB2C104J	RES. CARBON	100K	5%	1/6W
R046	RD14BB2C243J	RES. CARBON	24K	5%	1/6W
R047	RD14BB2C103J	RES. CARBON	10K	5%	1/6W
R048	RD14BB2C101J	RES. CARBON	100	5%	1/6W
U001	NJM4558D	IC, DUAL OP AMP			
VR001	R12-5524-05	RES. SEMI FIXED	100K	B	
VR002	R12-8501-05	RES. SEMI FIXED	2.2M	B	

SWITCH UNIT

X69-1150-01

REF. NO	PARTS NO	NAME & DESCRIPTION			
	J25-5233-03	PCB (UNMOUNTED)			
D038	B30-0964-05	LED			
D039	B30-0965-05	LED			
D040	B30-0964-05	LED			
D041	B30-0965-05	LED			
D042	B30-0964-05	LED			
D043	B30-0965-05	LED			
D044	B30-0965-05	LED			
D045	1SS132	DIODE			
D046	1SS132	DIODE			
D047	1SS132	DIODE			
D048	1SS132	DIODE			
D049	1SS132	DIODE			
P001	E40-7036-05	PIN CONNECTOR	20P		
R015	R90-0652-05	RES. NETWORK	6X10K	5%	
R016	R90-0653-05	RES. NETWORK	8X10K	5%	
R017	R90-0614-05	RES. NETWORK	8X390	5%	
R018	R90-0639-05	RES. NETWORK	6X390	5%	
R019	R90-0639-05	RES. NETWORK	6X390	5%	
R020	R90-0639-05	RES. NETWORK	6X390	5%	
R021	RD14BB2C391J	RES. CARBON	390	5%	1/6W
R022	RD14BB2C391J	RES. CARBON	390	5%	1/6W
R023	RD14BB2C391J	RES. CARBON	390	5%	1/6W

PARTS LIST

REF. NO	PARTS NO	NAME & DESCRIPTION
S001	W02-0810-05	ROTARY ENCODER
S002	W02-0810-05	ROTARY ENCODER
S003	W02-0810-05	ROTARY ENCODER
S004	S40-2525-05	SWITCH
S005	S40-2525-05	SWITCH
S006	S40-2525-05	SWITCH
S007	S40-2525-05	SWITCH
S008	S40-2525-05	SWITCH
S009	S40-2525-05	SWITCH
S010	S40-2525-05	SWITCH
S011	S40-2525-05	SWITCH
S012	S40-2525-05	SWITCH
S013	S40-2525-05	SWITCH
S014	S40-2525-05	SWITCH
S015	S40-2525-05	SWITCH
S016	S40-2525-05	SWITCH
S017	S40-2525-05	SWITCH
S018	S40-2525-05	SWITCH
S019	S40-2525-05	SWITCH
S020	S40-2525-05	SWITCH
S021	S40-2525-05	SWITCH
S022	S40-2525-05	SWITCH
S023	S40-2525-05	SWITCH
S024	S40-2525-05	SWITCH
S025	S40-2525-05	SWITCH
S026	S40-2525-05	SWITCH
S027	S40-2525-05	SWITCH
S028	S40-2525-05	SWITCH
S029	S40-2525-05	SWITCH
S030	NO USE	
S031	S40-2525-05	SWITCH
S032	S40-2525-05	SWITCH
S033	S40-2525-05	SWITCH
S034	S40-2525-05	SWITCH
S035	S40-2525-05	SWITCH
S036	S40-2525-05	SWITCH
S037	S40-2525-05	SWITCH
U002	HD74HC595AP	IC, 8-BIT SHIFT REGISTER/LATCH
U003	HD74HC595AP	IC, 8-BIT SHIFT REGISTER/LATCH
U004	HD74HC595AP	IC, 8-BIT SHIFT REGISTER/LATCH
U005	HD74HC595AP	IC, 8-BIT SHIFT REGISTER/LATCH
U006	HD74HC595AP	IC, 8-BIT SHIFT REGISTER/LATCH
U007	HD74HC595AP	IC, 8-BIT SHIFT REGISTER/LATCH
U008	HD74HC595AP	IC, 8-BIT SHIFT REGISTER/LATCH
U009	HD74HC595AP	IC, 8-BIT SHIFT REGISTER/LATCH

REF. NO	PARTS NO	NAME & DESCRIPTION
C039	CK45F1H103Z	CAP. CERAMIC 0.01 50V
C040	CK45FF1H103Z	CAP. CERAMIC 0.01 50V
C041	CC45CH1H101J	CAP. CERAMIC 100P 5% 50V
C042	CC45CH1H101J	CAP. CERAMIC 100P 5% 50V
C043	CC45CH1H101J	CAP. CERAMIC 100P 5% 50V
C044	CC45CH1H101J	CAP. CERAMIC 100P 5% 50V
C045	C092FM1H104K	CAP. MYLAR 0.1 10% 50V
C046	CK45FF1H103Z	CAP. CERAMIC 0.01 50V
C103	CC45FCH1H020C	CAP. CERAMIC 2P 0.25P 50V
C104	CC45FCH1H050C	CAP. CERAMIC 5P 0.25P 50V
C105	NO USE	
C106	CC45FCH1H060D	CAP. CERAMIC 6P 0.5P 50V
C107	CK45FF1H103Z	CAP. CERAMIC 0.01 50V
C108	CC45FCH1H150J	CAP. CERAMIC 15P 5% 50V
C109	CK45B1H102K	CAP. CERAMIC 1000P 10% 50V
C110	CC45CH1H010C	CAP. CERAMIC 1P 0.25P 50V
C111	CC45FCH1H030C	CAP. CERAMIC 3P 0.25P 50V
C112	CC45CH1H010C	CAP. CERAMIC 1P 0.25P 50V
C113	CC45FCH1H020C	CAP. CERAMIC 2P 0.25P 50V
C114	CC45FCH1H020C	CAP. CERAMIC 2P 0.25P 50V
C203	CC45FCH1H020C	CAP. CERAMIC 2P 0.25P 50V
C204	CC45FCH1H050C	CAP. CERAMIC 5P 0.25P 50V
C205	NO USE	
C206	CC45FCH1H060D	CAP. CERAMIC 6P 0.5P 50V
C207	NO USE	
C208	CC45FCH1H150J	CAP. CERAMIC 15P 5% 50V
C209	CK45B1H102K	CAP. CERAMIC 1000P 10% 50V
C210	CC45CH1H010C	CAP. CERAMIC 1P 0.25P 50V
C211	CC45FCH1H030C	CAP. CERAMIC 3P 0.25P 50V
C212	CC45CH1H010C	CAP. CERAMIC 1P 0.25P 50V
C213	CC45FCH1H020C	CAP. CERAMIC 2P 0.25P 50V
C214	CC45FCH1H020C	CAP. CERAMIC 2P 0.25P 50V
C301	CK45FF1H103Z	CAP. CERAMIC 0.01 50V
C401	CK45FF1H103Z	CAP. CERAMIC 0.01 50V
C402	C092FM1H104K	CAP. MYLAR 0.1 10% 50V
C501	CC45FCH1H680J	CAP. CERAMIC 68P 5% 50V
C502	CC45FCH1H680J	CAP. CERAMIC 68P 5% 50V
C503	CC45CH1H120J	CAP. CERAMIC 12P 5% 50V
C504	CC45CH1H120J	CAP. CERAMIC 12P 5% 50V
C505	CC45FCH1H020C	CAP. CERAMIC 2P 0.25P 50V
C506	CC45FCH1H020C	CAP. CERAMIC 2P 0.25P 50V
C509	CC45SL1H471J	CAP. CERAMIC 470P 5% 50V
C510	CC45SL1H471J	CAP. CERAMIC 470P 5% 50V
C511	C092FM1H104K	CAP. MYLAR 0.1 10% 50V
C512	NO USE	
C513	CC45FCH1H040C	CAP. CERAMIC 4P 0.25P 50V
C514	CC45FCH1H040C	CAP. CERAMIC 4P 0.25P 50V
C515	CC45FCH1H040C	CAP. CERAMIC 4P 0.25P 50V
C516	CC45FCH1H040C	CAP. CERAMIC 4P 0.25P 50V
C517	C092FM1H103K	CAP. MYLAR 0.01 10% 50V
C518	C092FM1H104K	CAP. MYLAR 0.1 10% 50V
C519	CK45FF1H103Z	CAP. CERAMIC 0.01 50V
C520	CC45FCH1H101J	CAP. CERAMIC 100P 5% 50V
C601	CC45FCH1H070D	CAP. CERAMIC 7P 0.5P 50V
C602	CC45FCH1H070D	CAP. CERAMIC 7P 0.5P 50V
C603	CC45FCH1H120J	CAP. CERAMIC 12P 5% 50V
C604	CC45FCH1H120J	CAP. CERAMIC 12P 5% 50V
C605	CE04HW1H010M	CAP. ELECTRO 1 20% 50V
C606	CC45CH1H010C	CAP. CERAMIC 1P 0.25P 50V
C607	CE04HW1E220M	CAP. ELECTRO 22 20% 25V
C608	CK45FF1H103Z	CAP. CERAMIC 0.01 50V
C609	CK45FF1H103Z	CAP. CERAMIC 0.01 50V
C610	CK45FF1H103Z	CAP. CERAMIC 0.01 50V
C611	NO USE	
C612	CC45FCH1H020C	CAP. CERAMIC 2P 0.25P 50V
C701	CC45FCH1H470J	CAP. CERAMIC 47P 5% 50V
C702	CC45FCH1H470J	CAP. CERAMIC 47P 5% 50V
C703	CK45FF1H103Z	CAP. CERAMIC 0.01 50V
C704	CK45FF1H103Z	CAP. CERAMIC 0.01 50V
C705	CC45FCH1H220J	CAP. CERAMIC 22P 5% 50V
C706	CC45FCH1H220J	CAP. CERAMIC 22P 5% 50V
C707	C092M1H104K	CAP. MYLAR 0.1 10% 50V
C708	NO USE	
C709	CK45FF1H103Z	CAP. CERAMIC 0.01 50V
C710	NO USE	
C711	CK45FF1H103Z	CAP. CERAMIC 0.01 50V
C714	CE04EW1A101M	CAP. ELECTRO 100 20% 10V
C715	CE04EW1A101M	CAP. ELECTRO 100 20% 10V
C716	CE04EW1C330M	CAP. ELECTRO 33 20% 16V
C720	C092FM1H104K	CAP. MYLAR 0.1 10% 50V
C721	C092FM1H104K	CAP. MYLAR 0.1 10% 50V

VERTICAL PREAMP UNIT

X73-1760-00

REF. NO	PARTS NO	NAME & DESCRIPTION
	E31-5576-05	WIRE ASS'Y(GND TO GND)
	E31-5577-05	WIRE ASS'Y(NO.A,B,C,D)
	J25-5228-02	PCB (UNMOUNTED)
	J61-0408-05	WIRE WRAPPING BAND
C001	CK45FF1H103Z	CAP. CERAMIC 0.01 50V
C002	CK45FF1H103Z	CAP. CERAMIC 0.01 50V
C003	CK45FF1H103Z	CAP. CERAMIC 0.01 50V
C004	CE04EW1A101M	CAP. ELECTRO 100 20% 10V
C005	CK45FF1H103Z	CAP. CERAMIC 0.01 50V
C006	CK45FF1H103Z	CAP. CERAMIC 0.01 50V
C007	CK45FF1H103Z	CAP. CERAMIC 0.01 50V
C008	CK45FF1H103Z	CAP. CERAMIC 0.01 50V
C009	CK45FF1H103Z	CAP. CERAMIC 0.01 50V
C019	CK45FF1H103Z	CAP. CERAMIC 0.01 50V
C020	CK45FF1H103Z	CAP. CERAMIC 0.01 50V
C021	CE04EW1C100M	CAP. ELECTRO 10 20% 16V
C022	CE04EW1C100M	CAP. ELECTRO 10 20% 16V
C023	NO USE	
C024	CE04EW1C470M	CAP. ELECTRO 47 20% 16V
C025	C092FM1H103K	CAP. MYLAR 0.01 10% 50V
C026	CK45FF1H103Z	CAP. CERAMIC 0.01 50V
C027	CE04EW1C470M	CAP. ELECTRO 47 20% 16V
C028	CE04EW1C470M	CAP. ELECTRO 47 20% 16V
C029	CC45FCH1H470J	CAP. CERAMIC 47P 5% 50V
C030	CC45FCH1H470J	CAP. CERAMIC 47P 5% 50V
C031	CC45FCH1H470J	CAP. CERAMIC 47P 5% 50V
C032	CC45FCH1H470J	CAP. CERAMIC 47P 5% 50V
C033	CE04EW1C470M	CAP. ELECTRO 47 20% 16V
C034	CK45FF1H103Z	CAP. CERAMIC 0.01 50V
C035	CK45FF1H103Z	CAP. CERAMIC 0.01 50V
C036	CK45FF1H103Z	CAP. CERAMIC 0.01 50V
C037	CE04EW1C470M	CAP. ELECTRO 47 20% 16V
C038	CK45F1H103Z	CAP. CERAMIC 0.01 50V

PARTS LIST

REF.NO	PARTS NO	NAME & DESCRIPTION				REF.NO	PARTS NO	NAME & DESCRIPTION			
C800	CC45CH1H101J	CAP.	CERAMIC	100P	5%	50V	Q116	2SC2785(F)	TR.	SI.	NPN
C801	CC45CH1H101J	CAP.	CERAMIC	100P	5%	50V	Q117	2SC3779(D)	TR.	SI.	NPN
C802	CC45CH1H330J	CAP.	CERAMIC	33P	5%	50V	Q118	2SC3779(D)	TR.	SI.	NPN
C803	CC45SL1H470J	CAP.	CERAMIC	47P	5%	50V	Q119	2SC3779(D)	TR.	SI.	NPN
C804	CC45SL1H470J	CAP.	CERAMIC	47P	5%	50V	Q120	2SC3779(D)	TR.	SI.	NPN
C805	C092M1H104K	CAP.	MYLAR	0.1	10%	50V	Q201	2SC4072	TR.	SI.	NPN
C806	C092M1H104K	CAP.	MYLAR	0.1	10%	50V	Q202	2SC4072	TR.	SI.	NPN
C807	CC45CH1HOR5C	CAP.	CERAMIC	0.5P	0.25P	50V	Q203	2SC3779(D)	TR.	SI.	NPN
C808	CC45CH1HOR5C	CAP.	CERAMIC	0.5P	0.25P	50V	Q204	2SC3779(D)	TR.	SI.	NPN
D101	1SS132	DIODE				Q205	2SC3315(C)	TR.	SI.	NPN	
D102	1SS132	DIODE				Q206	2SC3315(C)	TR.	SI.	NPN	
D103	MA700	DIODE				Q207	2SC3315(C)	TR.	SI.	NPN	
D104	MA700	DIODE				Q208	2SA1161	TR.	SI.	PNP	
D150	MA700	DIODE				Q209	2SA1161	TR.	SI.	PNP	
D151	MA700	DIODE				Q210	2SC4049	TR.	SI.	NPN	
D152	MA700	DIODE				Q211	2SC4049	TR.	SI.	NPN	
D153	MA700	DIODE				Q212	2SC3779(D)	TR.	SI.	NPN	
D154	MA700	DIODE				Q213	2SC3779(D)	TR.	SI.	NPN	
D155	MA700	DIODE				Q214	2SC3779(D)	TR.	SI.	NPN	
Q201	1SS132	DIODE				Q215	2SC3779(D)	TR.	SI.	NPN	
Q202	1SS132	DIODE				Q216	2SC2785(F)	TR.	SI.	NPN	
Q203	MA700	DIODE				Q217	2SC3779(D)	TR.	SI.	NPN	
Q204	MA700	DIODE				Q218	2SC3779(D)	TR.	SI.	NPN	
Q250	MA700	DIODE				Q219	2SC3779(D)	TR.	SI.	NPN	
Q251	MA700	DIODE				Q220	2SC3779(D)	TR.	SI.	NPN	
Q252	MA700	DIODE				Q301	2SC3779(D)	TR.	SI.	NPN	
Q253	MA700	DIODE				Q302	2SC3779(D)	TR.	SI.	NPN	
Q254	MA700	DIODE				Q303	2SC3779(D)	TR.	SI.	NPN	
Q255	MA700	DIODE				Q304	2SC3779(D)	TR.	SI.	NPN	
Q501	1SS132	DIODE				Q401	2SC3779(D)	TR.	SI.	NPN	
Q502	1SS132	DIODE				Q402	2SC3779(D)	TR.	SI.	NPN	
Q503	1SS132	DIODE				Q403	2SC3779(D)	TR.	SI.	NPN	
Q504	1SS132	DIODE				Q404	2SC3779(D)	TR.	SI.	NPN	
Q505	1SS132	DIODE				Q501	2SA1206	TR.	SI.	PNP	
Q506	1SS132	DIODE				Q502	2SA1206	TR.	SI.	PNP	
Q507	1SS132	DIODE				Q503	2SC3315(C)	TR.	SI.	NPN	
Q508	1SS132	DIODE				Q504	2SC3315(C)	TR.	SI.	NPN	
Q509	1SS132	DIODE				Q505	2SA1206	TR.	SI.	PNP	
Q510	MTZ10JC	DIODE, ZENER		9.95V		Q506	2SA1206	TR.	SI.	PNP	
Q511	1SS132	DIODE				Q507	2SC3315(C)	TR.	SI.	NPN	
Q512	MTZ5.1JB	DIODE, ZENER		5.07V		Q508	2SC3315(C)	TR.	SI.	NPN	
D601	DAP401	DIODE ARRAY				Q509	2SA1206	TR.	SI.	PNP	
D602	DAP401	DIODE ARRAY				Q510	2SA1206	TR.	SI.	PNP	
D603	1SS132	DIODE				Q511	2SC3315(C)	TR.	SI.	NPN	
K101	SS1-2508-05	RELAY				Q512	2SC3315(C)	TR.	SI.	NPN	
K102	SS1-2508-05	RELAY				Q513	2SA1206	TR.	SI.	PNP	
K201	SS1-2508-05	RELAY				Q514	2SA1206	TR.	SI.	PNP	
K202	SS1-2508-05	RELAY				Q515	2SC3315(C)	TR.	SI.	NPN	
P005	E40-0373-05	PIN CONNECTOR		3P		Q516	2SC3315(C)	TR.	SI.	NPN	
P006	E40-0373-05	PIN CONNECTOR		3P		Q517	NO USE				
P007	E40-0473-05	PIN CONNECTOR		4P		Q518	2SC3732(L)	TR.	SI.	NPN	
P008	E40-0473-05	PIN CONNECTOR		4P		Q519	2SA1206	TR.	SI.	PNP	
P009	E40-0373-05	PIN CONNECTOR		3P		Q520	2SA1206	TR.	SI.	PNP	
P010	E40-7039-05	PIN CONNECTOR		20P		Q521	2SA1175(F)	TR.	SI.	PNP	
P011	E40-0373-05	PIN CONNECTOR		3P		Q522	2SA1175(F)	TR.	SI.	PNP	
P030	E40-0273-05	PIN CONNECTOR		2P		Q523	2SA1175(F)	TR.	SI.	PNP	
Q001	2SA1005(K)	TR.	SI.	PNP		Q524	2SC3779(D)	TR.	SI.	NPN	
Q002	2SA1005(K)	TR.	SI.	PNP		Q525	2SC3779(D)	TR.	SI.	NPN	
Q003	2SA1005(K)	TR.	SI.	PNP		Q526	2SA1206	TR.	SI.	PNP	
Q004	2SA1005(K)	TR.	SI.	PNP		Q527	2SA1206	TR.	SI.	PNP	
Q005	2SA1005(K)	TR.	SI.	PNP		Q528	2SA1161	TR.	SI.	PNP	
Q006	2SA1005(K)	TR.	SI.	PNP		Q529	2SA1161	TR.	SI.	PNP	
Q007	2SA1005(K)	TR.	SI.	PNP		Q601	2SA1206	TR.	SI.	PNP	
Q008	2SA1005(K)	TR.	SI.	PNP		Q602	2SA1206	TR.	SI.	PNP	
Q101	2SC4072	TR.	SI.	NPN		Q603	2SC3779(D)	TR.	SI.	NPN	
Q102	2SC4072	TR.	SI.	NPN		Q604	2SA1206	TR.	SI.	PNP	
Q103	2SC3779(D)	TR.	SI.	NPN		Q605	2SA1206	TR.	SI.	PNP	
Q104	2SC3779(D)	TR.	SI.	NPN		Q606	2SA1206	TR.	SI.	PNP	
Q105	2SC3315(C)	TR.	SI.	NPN		Q607	2SC3779(D)	TR.	SI.	NPN	
Q106	2SC3315(C)	TR.	SI.	NPN		Q608	2SA1206	TR.	SI.	PNP	
Q107	2SC3315(C)	TR.	SI.	NPN		Q609	2SA1206	TR.	SI.	PNP	
Q108	2SA1161	TR.	SI.	PNP		Q610	2SA1206	TR.	SI.	PNP	
Q109	2SA1161	TR.	SI.	PNP		Q611	2SC3779(D)	TR.	SI.	NPN	
Q110	2SC4049	TR.	SI.	NPN		Q612	2SA1206	TR.	SI.	PNP	
Q111	2SC4049	TR.	SI.	NPN		Q613	2SA1206	TR.	SI.	PNP	
Q112	2SC3779(D)	TR.	SI.	NPN		Q614	2SA1206	TR.	SI.	PNP	
Q113	2SC3779(D)	TR.	SI.	NPN		Q615	2SC3779(D)	TR.	SI.	NPN	
Q114	2SC3779(D)	TR.	SI.	NPN		Q616	2SA1206	TR.	SI.	PNP	
Q115	2SC3779(D)	TR.	SI.	NPN		Q617	2SA1161	TR.	SI.	PNP	
						Q618	2SA1161	TR.	SI.	PNP	
						Q619	2SA1175(F)	TR.	SI.	PNP	
						Q620	2SA1175(F)	TR.	SI.	PNP	
						Q621	2SC3779(D)	TR.	SI.	NPN	
						Q622	2SC3779(D)	TR.	SI.	NPN	
						Q623	2SC2785(F)	TR.	SI.	NPN	
						Q624	2SC3315(C)	TR.	SI.	NPN	

PARTS LIST

REF.NO	PARTS NO	NAME & DESCRIPTION
R634	NO USE	
R635	RD14BB2C302J	RES. CARBON 3K 5% 1/6W
R636	RD14BB2C220J	RES. CARBON 22 5% 1/6W
R637	RN14BK2C1001F	RES. METAL FILM 1K 1% 1/6W
R638	RN14BK2C5600F	RES. METAL FILM 560 1% 1/6W
R639	RD14BB2C101J	RES. CARBON 100 5% 1/6W
R640	RD14BB2C220J	RES. CARBON 22 5% 1/6W
R641	RD14BB2C220J	RES. CARBON 22 5% 1/6W
R642	RN14BK2C1001F	RES. METAL FILM 1K 1% 1/6W
R643	RD14BB2C101J	RES. CARBON 100 5% 1/6W
R644	RN14BK2C1001F	RES. METAL FILM 1K 1% 1/6W
R645	RN14BK2C1001F	RES. METAL FILM 1K 1% 1/6W
R646	RN14BK2C1300F	RES. METAL FILM 130 1% 1/6W
R647	NO USE	
R648	RD14BB2C302J	RES. CARBON 3K 5% 1/6W
R649	RD14BB2C220J	RES. CARBON 22 5% 1/6W
R650	RN14BK2C1001F	RES. METAL FILM 1K 1% 1/6W
R651	RN14BK2C5600F	RES. METAL FILM 560 1% 1/6W
R652	RD14BB2C101J	RES. CARBON 100 5% 1/6W
R653	RD14BB2C822J	RES. CARBON 8.2K 5% 1/6W
R654	RD14BB2C222J	RES. CARBON 2.2K 5% 1/6W
R655	R90-0657-05	RES. MULTIPLE 8X330 1%
R656	RD14BB2C331J	RES. CARBON 330 5% 1/6W
R657	RN14BK2C7500F	RES. METAL FILM 750 1% 1/6W
R658	RN14BK2C7500F	RES. METAL FILM 750 1% 1/6W
R659	RN14BK2C4701F	RES. METAL FILM 4.7K 1% 1/6W
R660	RN14BK2C4701F	RES. METAL FILM 4.7K 1% 1/6W
R661	RN14BK2C2701F	RES. METAL FILM 2.7K 1% 1/6W
R662	RN14BK2C2701F	RES. METAL FILM 2.7K 1% 1/6W
R663	RD14BB2C220J	RES. CARBON 22 5% 1/6W
R664	RD14BB2C220J	RES. CARBON 22 5% 1/6W
R665	RD14BB2C220J	RES. CARBON 22 5% 1/6W
R666	RD14BB2C220J	RES. CARBON 22 5% 1/6W
R667	RD14BB2C220J	RES. CARBON 22 5% 1/6W
R668	RD14BB2C220J	RES. CARBON 22 5% 1/6W
R669	RD14BB2C220J	RES. CARBON 22 5% 1/6W
R670	RD14BB2C220J	RES. CARBON 22 5% 1/6W
R671	RD14BB2C102J	RES. CARBON 1K 5% 1/6W
R672	RD14BB2C470J	RES. CARBON 47 5% 1/6W
R673	RD14BB2C470J	RES. CARBON 47 5% 1/6W
R674	RN14BK2C2701F	RES. METAL FILM 2.7K 1% 1/6W
R675	RN14BK2C1002F	RES. METAL FILM 10K 1% 1/6W
R676	E31-2170-05	JUMPING WIRE
R677	RD14BB2C470J	RES. CARBON 47 5% 1/6W
R678	RD14BB2C101J	RES. CARBON 100 5% 1/6W
R679	RD14BB2C622J	RES. CARBON 6.2K 5% 1/6W
R680	RN14BK2C1001F	RES. METAL FILM 1K 1% 1/6W
R681	RN14BK2C8200F	RES. METAL FILM 820 1% 1/6W
R682	RN14BK2C1601F	RES. METAL FILM 1.6K 1% 1/6W
R683	RD14BB2C391J	RES. CARBON 390 5% 1/6W
R684	RD14BB2C300J	RES. CARBON 30 5% 1/6W
R685	RD14BB2C104J	RES. CARBON 100K 5% 1/6W
R686	RD14BB2C111J	RES. CARBON 110 5% 1/6W
R687	RD14BB2C470J	RES. CARBON 47 5% 1/6W
R688	RD14BB2C470J	RES. CARBON 47 5% 1/6W
R689	RD14BB2C470J	RES. CARBON 47 5% 1/6W
R690	RD14BB2C470J	RES. CARBON 47 5% 1/6W
R691	RN14BK2C6801F	RES. METAL FILM 6.8K 1% 1/6W
R701	RD14BB2C101J	RES. CARBON 100 5% 1/6W
R702	RD14BB2C202J	RES. CARBON 2K 5% 1/6W
R703	RD14BB2C470J	RES. CARBON 47 5% 1/6W
R704	RN14BK2C5600F	RES. METAL FILM 560 1% 1/6W
R705	RN14BK2C1601F	RES. METAL FILM 1.6K 1% 1/6W
R706	RD14BB2C101J	RES. CARBON 100 5% 1/6W
R707	RD14BB2C202J	RES. CARBON 2K 5% 1/6W
R708	RD14BB2C470J	RES. CARBON 47 5% 1/6W
R709	RN14BK2C5600F	RES. METAL FILM 560 1% 1/6W
R710	RN14BK2C1601F	RES. METAL FILM 1.6K 1% 1/6W
R711	RD14BB2C470J	RES. CARBON 47 5% 1/6W
R712	RD14BB2C470J	RES. CARBON 47 5% 1/6W
R713	RD14BB2C470J	RES. CARBON 47 5% 1/6W
R714	RD14BB2C470J	RES. CARBON 47 5% 1/6W
R800	RD14BB2C470J	RES. CARBON 47 5% 1/6W
R801	RD14BB2C470J	RES. CARBON 47 5% 1/6W
R802	RD14BB2C561J	RES. CARBON 560 5% 1/6W
R810	RD14BB2C470J	RES. CARBON 47 5% 1/6W
R811	RD14BB2C470J	RES. CARBON 47 5% 1/6W
R812	RD14BB2C470J	RES. CARBON 47 5% 1/6W
R813	RD14BB2C470J	RES. CARBON 47 5% 1/6W
TC101	C05-0469-05	CAP. TRIMMER 10P
TC201	C05-0469-05	CAP. TRIMMER 10P
TC501	C05-0469-05	CAP. TRIMMER 10P
TC502	C05-0469-05	CAP. TRIMMER 10P
TC503	C05-0469-05	CAP. TRIMMER 10P
TC504	C05-0469-05	CAP. TRIMMER 10P

REF.NO	PARTS NO	NAME & DESCRIPTION
TH501	SDT100	THERMISTOR
U001	HD74HC595P	IC. 8-BIT SHIFT REGISTER/LATCH
U002	HD74HC595P	IC. 8-BIT SHIFT REGISTER/LATCH
U003	HD74HC595P	IC. 8-BIT SHIFT REGISTER/LATCH
U004	HD74LS42P	IC. BCD TO DECIMAL DECODER
U005	SN74ALS00AN	IC. QUAD 2 INPUT NAND GATE
U006	SN74ALS112AN	IC. DUAL J-K F.F. (WITH PR&CLR)
U007	SN74ALS00AN	IC. QUAD 2 INPUT NAND GATE
U008	SN74ALS112AN	IC. DUAL J-K F.F. (WITH PR&CLR)
U009	SN74ALS00AN	IC. QUAD 2 INPUT NAND GATE
U101	NJM4558D	IC. DUAL OP AMP
U201	NJM4558D	IC. DUAL OP AMP
VR101	R12-0569-05	RES. SEMI FIXED 100B
VR102	R12-0569-05	RES. SEMI FIXED 100B
VR103	R12-2520-05	RES. SEMI FIXED 5KB
VR104	R12-3543-05	RES. SEMI FIXED 20KB
VR201	R12-0569-05	RES. SEMI FIXED 100B
VR202	R12-0569-05	RES. SEMI FIXED 100B
VR203	R12-2520-05	RES. SEMI FIXED 5KB
VR204	R12-3543-05	RES. SEMI FIXED 20KB
VR501	R12-0570-05	RES. SEMI FIXED 200B
VR502	R12-1538-05	RES. SEMI FIXED 1KB
VR503	R12-3543-05	RES. SEMI FIXED 20KB
VR504	R12-0570-05	RES. SEMI FIXED 200B
VR505	R12-1538-05	RES. SEMI FIXED 1KB
VR506	R12-3543-05	RES. SEMI FIXED 20KB
VR507	R12-0570-05	RES. SEMI FIXED 200B
VR508	R12-1538-05	RES. SEMI FIXED 1KB
VR509	R12-3543-05	RES. SEMI FIXED 20KB
VR510	R12-0570-05	RES. SEMI FIXED 200B
VR511	R12-1538-05	RES. SEMI FIXED 1KB
VR512	R12-3543-05	RES. SEMI FIXED 20KB
VR513	R12-3543-05	RES. SEMI FIXED 20KB
VR601	R12-3543-05	RES. SEMI FIXED 20KB
VR602	R12-3543-05	RES. SEMI FIXED 20KB
VR603	R12-3543-05	RES. SEMI FIXED 20KB
VR604	R12-3543-05	RES. SEMI FIXED 20KB

HORIZONTAL UNIT

X74-1480-01

REF.NO	PARTS NO	NAME & DESCRIPTION
	E31-5572-05	WIRE ASS'Y (NO. 1)
	J25-5229-02	PCB (UNMOUNTED)
	R92-1061-05	JUMPING RES.
C001	CE04HW1H010M	CAP. ELECTRO 1 20% 50V
C002	NO USE	
C003	CC45FCH1H030C	CAP. CERAMIC 3P 0.25P 50V
C004	NO USE	
C005	C092FM1H104K	CAP. MYLAR 0.1 10% 50V
C006	CC45FCH1H221J	CAP. CERAMIC 220P 5% 50V
C007	CC45FCH1H200J	CAP. CERAMIC 20P 5% 50V
C008	CF92V1H333J	CAP. PLASTIC FILM 0.033 5% 50V
C009	CF92V1H684J	CAP. PLASTIC FILM 0.68 5% 50V
C010	CF92V1H684J	CAP. PLASTIC FILM 0.68 5% 50V
C011	CE04EW1A470M	CAP. ELECTRO 47 20% 10V
C012	CC45FCH1H150J	CAP. CERAMIC 15P 5% 50V
C013	CE04HW1H010M	CAP. ELECTRO 1 20% 50V
C014	CC45FCH1H030C	CAP. CERAMIC 3P 0.25P 50V
C015	CC45FCH1H150J	CAP. CERAMIC 15P 5% 50V
C016	C092FM1H104K	CAP. MYLAR 0.1 10% 50V
C017	CC45FCH1H200J	CAP. CERAMIC 20P 5% 50V
C018	CF92V1H333J	CAP. PLASTIC FILM 0.033 5% 50V
C019	CC45FCH1H221J	CAP. CERAMIC 220P 5% 50V
C020	CK45FF1H1032	CAP. CERAMIC 0.01 50V
C021	CK45FF1H1032	CAP. CERAMIC 0.01 50V
C022	NO USE	
C023	CK45FF1H1032	CAP. CERAMIC 0.01 50V
C024	CK45FF1H1032	CAP. CERAMIC 0.01 50V
C025	NO USE	
C026	CK45FF1H1032	CAP. CERAMIC 0.01 50V
C027	CK45FF1H1032	CAP. CERAMIC 0.01 50V

PARTS LIST

REF. NO	PARTS NO	NAME & DESCRIPTION
C101	CC45FCH1H050C	CAP. CERAMIC 5P 0.25P 50V
C102	CK45FB1H222K	CAP. CERAMIC 2200P 10% 50V
C103	C092FM1H104K	CAP. MYLAR 0.1 10% 50V
C104	CC45FCH1H050C	CAP. CERAMIC 5P 0.25P 50V
C105	CK45FB1H222K	CAP. CERAMIC 2200P 10% 50V
C106	CK45FB1H222K	CAP. CERAMIC 2200P 10% 50V
C107	CE04EW1A470M	CAP. ELECTRO 47 20% 10V
C108	CK45FF1H103Z	CAP. CERAMIC 0.01 50V
C109	CC45FCH1H101J	CAP. CERAMIC 100P 5% 50V
C110	CM93BD2A101J	CAP. MICA 100P 5% 100V
C111	C91-1272-05	CAP. PLASTIC FILM 1.5 5% 100V
C112	CE04EW1C220M	CAP. ELECTRO 22 20% 16V
C113	CE04EW1A470M	CAP. ELECTRO 47 20% 10V
C114	CE04EW1C220M	CAP. ELECTRO 22 20% 16V
C115	CC45FSL1H391J	CAP. CERAMIC 390P 5% 50V
C116	C092FM1H104K	CAP. MYLAR 0.1 10% 50V
C117	CE04HW1H010M	CAP. ELECTRO 1 20% 50V
C118	CC45FCH1H470J	CAP. CERAMIC 47P 5% 50V
C119	NO USE	
C120	CC45FCH1H470J	CAP. CERAMIC 47P 5% 50V
C121	CC45FCH1H680J	CAP. CERAMIC 68P 5% 50V
C122	CK45FF1H103Z	CAP. CERAMIC 0.01 50V
C123	CC45FCH1H101J	CAP. CERAMIC 100P 5% 50V
C124	CM93BD2A101J	CAP. MICA 100P 5% 100V
C125	C91-1272-05	CAP. PLASTIC FILM 1.5 5% 100V
C126	C092FM1H104K	CAP. MYLAR 0.1 10% 50V
C127	C092FM1H104K	CAP. MYLAR 0.1 10% 50V
C128	CE04EW1A470M	CAP. ELECTRO 47 20% 10V
C129	CC45FCH1H470J	CAP. CERAMIC 47P 5% 50V
C130	CK45FB1H102K	CAP. CERAMIC 1000P 10% 50V
C131	CK45FB1H102K	CAP. CERAMIC 1000P 10% 50V
C132	CK45FF1H103Z	CAP. CERAMIC 0.01 50V
C133	CC45FCH1H101J	CAP. CERAMIC 100P 5% 50V
C134	CE04EW1C330M	CAP. ELECTRO 33 20% 16V
C135	CE04EW1C330M	CAP. ELECTRO 33 20% 16V
C136	CE04HW1H010M	CAP. ELECTRO 1 20% 50V
C137	CE04EW1C220M	CAP. ELECTRO 22 20% 16V
C138	CC45FCH1H470J	CAP. CERAMIC 47P 5% 50V
C139	C092FM1H104K	CAP. MYLAR 0.1 10% 50V
C140	C092FM1H104K	CAP. MYLAR 0.1 10% 50V
C141	CC45FCH1H200J	CAP. CERAMIC 20P 5% 50V
C145	CK45FB1H102K	CAP. CERAMIC 1000P 10% 50V
C302	CE04EW1A470M	CAP. ELECTRO 47 20% 10V
C303	NO USE	
C304	CC45FCH1H470J	CAP. CERAMIC 47P 5% 50V
C305	CC45FCH1H101J	CAP. CERAMIC 100P 5% 50V
C306	C90-0987-05	CAP. ELECTRO 1000 20% 6.3V
C310	CC45FCH1H070D	CAP. CERAMIC 7P 0.5P 50V
C311	CC45FCH1H470J	CAP. CERAMIC 47P 5% 50V
C312	CK45FF1H103Z	CAP. CERAMIC 0.01 50V
C313	CC45FCH1H070D	CAP. CERAMIC 7P 0.5P 50V
C325	CE04EW1H2R2M	CAP. ELECTRO 2.2 20% 50V
C401	CC45FCH1H680J	CAP. CERAMIC 68P 5% 50V
C402	CC45FCH1H910J	CAP. CERAMIC 91P 5% 50V
C403	CC45FCH1H910J	CAP. CERAMIC 91P 5% 50V
C404	CK45FF1H103Z	CAP. CERAMIC 0.01 50V
C405	CC45FCH1H101J	CAP. CERAMIC 100P 5% 50V
C406	CE04EW1C100M	CAP. ELECTRO 10 20% 16V
C407	CC45FCH1H470J	CAP. CERAMIC 47P 5% 50V
C501	C092FM1H104K	CAP. MYLAR 0.1 10% 50V
C502	C092FM1H104K	CAP. MYLAR 0.1 10% 50V
C503	C092FM1H104K	CAP. MYLAR 0.1 10% 50V
C504	C092FM1H104K	CAP. MYLAR 0.1 10% 50V
C505	CK45FF1H103Z	CAP. CERAMIC 0.01 50V
C506	CK45FF1H103Z	CAP. CERAMIC 0.01 50V
C507	CK45FF1H103Z	CAP. CERAMIC 0.01 50V
C508	CK45FF1H103Z	CAP. CERAMIC 0.01 50V
C509	CK45FF1H103Z	CAP. CERAMIC 0.01 50V
C510	NO USE	
C511	CK45FF1H103Z	CAP. CERAMIC 0.01 50V
C512	CK45FF1H103Z	CAP. CERAMIC 0.01 50V
C513	CK45FF1H103Z	CAP. CERAMIC 0.01 50V
C519	CE04EW1A101M	CAP. ELECTRO 100 20% 10V
C533	CE04EW1A101M	CAP. ELECTRO 100 20% 10V
C534	CE04EW1A101M	CAP. ELECTRO 100 20% 10V
C551	CE04EW1A471M	CAP. ELECTRO 470 20% 10V
C552	CE04EW1C331M	CAP. ELECTRO 330 20% 16V
C553	CE04EW1C331M	CAP. ELECTRO 330 20% 16V

REF. NO	PARTS NO	NAME & DESCRIPTION
C554	CE04EW1A102M	CAP. ELECTRO 1000 20% 10V
C555	CE04EW1C101M	CAP. ELECTRO 100 20% 16V
C556	CK45FF1H103Z	CAP. CERAMIC 0.01 50V
C557	C092FM1H103K	CAP. MYLAR 0.01 10% 50V
C558	C092FM1H103K	CAP. MYLAR 0.01 10% 50V
C600	CC45CH1H270J	CAP. CERAMIC 27P 5% 50V
C601	CC45CH1H101J	CAP. CERAMIC 100P 5% 50V
C602	CC45SL1H471J	CAP. CERAMIC 470P 5% 50V
C603	CC45SL1H471J	CAP. CERAMIC 470P 5% 50V
D001	1SS132	DIODE
D002	1SS132	DIODE
D003	MA700	DIODE
D004	MA700	DIODE
D005	MA700	DIODE
D006	MA700	DIODE
D007	MA700	DIODE
D008	1SS132	DIODE
D009	1SS132	DIODE
D010	MA700	DIODE
D101	MA700	DIODE
D102	MA700	DIODE
D103	MA700	DIODE
D104	MA700	DIODE
D105	MA700	DIODE
D106	NO USE	
D107	MA700	DIODE
D108	NO USE	
D109	MA700	DIODE
D110	MA700	DIODE
D111	MA700	DIODE
D112	1SS132	DIODE
D113	1SS132	DIODE
D114	NO USE	
D115	MA700	DIODE
D116	MA700	DIODE
D117	MA700	DIODE
D118	1SS132	DIODE
D119	1SS132	DIODE
D120	1SS132	DIODE
D121	NO USE	
D122	MA700	DIODE
D123	MA700	DIODE
D124	1S1587	DIODE
D125	NO USE	
D126	1S1587	DIODE
D127	NO USE	
D128	1SS132	DIODE
D301	1SS132	DIODE
D302	1SS132	DIODE
D303	1SS132	DIODE
D304	NO USE	
D305	1SS132	DIODE
D306	NO USE	
D307	1SS132	DIODE
D308	1SS132	DIODE
D309	1SS132	DIODE
D315	1SS132	DIODE
D316	1SS132	DIODE
D350	MT23.3JA	DIODE, ZENER 3.27V
D351	1SS132	DIODE
D401	1SS132	DIODE
K001	SS1-1523-05	RELAY
K002	SS1-1523-05	RELAY
L001	L40-1011-04	FERRI INDUCTOR 100UH
L002	L40-2201-03	FERRI INDUCTOR 22UH
L003	L40-2201-03	FERRI INDUCTOR 22UH
P018	E40-7035-05	SOCKET 40P
Q001	2SC3779(D)	TR. SI, NPN
Q002	2SC3779(D)	TR. SI, NPN
Q003	2SA1565	TR. SI, PNP
Q004	2SC4049	TR. SI, NPN
Q005	2SA1206	TR. SI, PNP
Q006	2SC3779(D)	TR. SI, NPN
Q007	2SA1206	TR. SI, PNP
Q008	2SC2785(F)	TR. SI, NPN
Q009	2SC4049	TR. SI, NPN
Q010	2SC4049	TR. SI, NPN
Q014	2SC3779(D)	TR. SI, NPN
Q015	2SC3779(D)	TR. SI, NPN

PARTS LIST

REF.NO	PARTS NO	NAME & DESCRIPTION
0016	2SA1565	TR. SI, PNP
0017	2SA1206	TR. SI, PNP
0018	2SC3779(D)	TR. SI, NPN
0019	2SA1206	TR. SI, PNP
0020	2SC2785(F)	TR. SI, NPN
0101	2SC4049	TR. SI, NPN
0102	NO USE	
0103	2SA1206	TR. SI, PNP
0104	2SC2785(F)	TR. SI, NPN
0105	2SC4049	TR. SI, NPN
0106	2SC4049	TR. SI, NPN
0107	2SC4049	TR. SI, NPN
0108	NO USE	
0109	2SA1005(K)	TR. SI, PNP
0110	2SA1175(F)	TR. SI, PNP
0111	2SC3732(L)	TR. SI, NPN
0112	2SC3732(L)	TR. SI, NPN
0113	2SA1175(F)	TR. SI, PNP
0114	2SC3315(C)	TR. SI, NPN
0115	2SA1175(F)	TR. SI, PNP
0116	2SC3354(T,S)	TR. SI, NPN
0117	2SC3315(C)	TR. SI, NPN
0118	2SC2785(F)	TR. SI, NPN
0119	2SA1175(F)	TR. SI, PNP
0120	2SC2785(F)	TR. SI, NPN
0121	2SC3732(L)	TR. SI, NPN
0122	2SA1206	TR. SI, PNP
0123	2SC3315(C)	TR. SI, NPN
0124	2SA1206	TR. SI, PNP
0125	2SA1565	TR. SI, PNP
0126	2SA1206	TR. SI, PNP
0127	NO USE	
0128	2SA1005(K)	TR. SI, PNP
0129	2SA1175(F)	TR. SI, PNP
0130	2SC3732(L)	TR. SI, NPN
0131	2SC3732(L)	TR. SI, NPN
0132	2SA1175(F)	TR. SI, PNP
0133	2SC3315(C)	TR. SI, NPN
0134	2SC3354(T,S)	TR. SI, NPN
0135	2SC3315(C)	TR. SI, NPN
0136	2SC3732(L)	TR. SI, NPN
0137	2SC3732(L)	TR. SI, NPN
0301	2SA1175(F)	TR. SI, PNP
0302	2SC2785(F)	TR. SI, NPN
0303	2SC3315(C)	TR. SI, NPN
0304	2SC3315(C)	TR. SI, NPN
0305	2SC3315(C)	TR. SI, NPN
0306	2SC3315(C)	TR. SI, NPN
0307	2SC3315(C)	TR. SI, NPN
0308	2SC3315(C)	TR. SI, NPN
0309	2SC3315(C)	TR. SI, NPN
0310	2SA1565	TR. SI, PNP
0311	2SC3354(T,S)	TR. SI, NPN
0314	2SC3354(T,S)	TR. SI, NPN
0401	2SK583	FET, N-CHANNEL
0402	2SA1175(F)	TR. SI, PNP
0403	2SA1005(K)	TR. SI, PNP
0404	2SA1005(K)	TR. SI, PNP
0405	2SA1175(F)	TR. SI, PNP
0406	2SC2785(F)	TR. SI, NPN
R001	RD148B2C361J	RES. CARBON 360 5% 1/6W
R002	RN148K2C1801F	RES. METAL FILM 1.8K 1% 1/6W
R003	RN148K2C3901F	RES. METAL FILM 3.9K 1% 1/6W
R004	RN148K2C1600F	RES. METAL FILM 160 1% 1/6W
R005	RN148K2C1501F	RES. METAL FILM 1.5K 1% 1/6W
R006	NO USE	
R007	RD148B2C470J	RES. CARBON 47 5% 1/6W
R008	RD148B2C202J	RES. CARBON 2K 5% 1/6W
R009	RD148B2C153J	RES. CARBON 15K 5% 1/6W
R010	RN148K2C1003F	RES. METAL FILM 100K 1% 1/6W
R011	RN148K2C1003F	RES. METAL FILM 100K 1% 1/6W
R012	RD148B2C220J	RES. CARBON 22 5% 1/6W
R013	RD148B2C682J	RES. CARBON 6.8K 5% 1/6W
R014	RD148B2C302J	RES. CARBON 3K 5% 1/6W
R015	RD148B2C472J	RES. CARBON 4.7K 5% 1/6W
R016	RD148B2C470J	RES. CARBON 47 5% 1/6W
R017	RN148K2C2200F	RES. METAL FILM 220 1% 1/6W
R018	RN148K2C3301F	RES. METAL FILM 3.3K 1% 1/6W
R019	RD148B2C6800F	RES. METAL FILM 680 1% 1/6W
R020	RD148B2C101J	RES. CARBON 100 5% 1/6W
R021	RD148B2C470J	RES. CARBON 47 5% 1/6W
R022	RD148B2C181J	RES. CARBON 180 5% 1/6W
R023	RD148B2C102J	RES. CARBON 1K 5% 1/6W
R024	RN148K2C1003F	RES. METAL FILM 100K 1% 1/6W
R025	RD148B2C105J	RES. CARBON 1M 5% 1/6W
R026	RD148B2C105J	RES. CARBON 1M 5% 1/6W

REF.NO	PARTS NO	NAME & DESCRIPTION
RO27	RN148K2C1003F	RES. METAL FILM 100K 1% 1/6W
RO28	RD148B2C103J	RES. CARBON 10K 5% 1/6W
RO29	RD148B2C181J	RES. CARBON 180 5% 1/6W
RO33	RD148B2C754J	RES. CARBON 750K 5% 1/6W
RO34	RD148B2C754J	RES. CARBON 750K 5% 1/6W
RO35	RD148B2C105J	RES. CARBON 1M 5% 1/6W
RO36	RD148B2C105J	RES. CARBON 1M 5% 1/6W
RO37	RD148B2C472J	RES. CARBON 4.7K 5% 1/6W
RO38	RD148B2C361J	RES. CARBON 360 5% 1/6W
RO39	RN148K2C5100F	RES. METAL FILM 510 1% 1/6W
RO40	RD148B2C470J	RES. CARBON 47 5% 1/6W
RO41	RD148B2C470J	RES. CARBON 47 5% 1/6W
RO42	RN148K2C5100F	RES. METAL FILM 510 1% 1/6W
RO43	RN148K2C6801F	RES. METAL FILM 6.8K 1% 1/6W
RO44	RD148B2C103J	RES. CARBON 10K 5% 1/6W
RO45	NO USE	
RO46	RN148K2C6801F	RES. METAL FILM 6.8K 1% 1/6W
RO51	RD148B2C361J	RES. CARBON 360 5% 1/6W
RO52	RD148B2C162J	RES. CARBON 1.6K 5% 1/6W
RO53	RN148K2C3901F	RES. METAL FILM 3.9K 1% 1/6W
RO54	RN148K2C1600F	RES. METAL FILM 160 1% 1/6W
RO55	RN148K2C1501F	RES. METAL FILM 1.5K 1% 1/6W
RO56	NO USE	
RO57	RD148B2C470J	RES. CARBON 47 5% 1/6W
RO58	RD148B2C202J	RES. CARBON 2K 5% 1/6W
RO59	RD148B2C153J	RES. CARBON 15K 5% 1/6W
RO60	RN148K2C1003F	RES. METAL FILM 100K 1% 1/6W
RO61	RN148K2C1003F	RES. METAL FILM 100K 1% 1/6W
RO62	RD148B2C220J	RES. CARBON 22 5% 1/6W
RO63	RD148B2C682J	RES. CARBON 6.8K 5% 1/6W
RO64	RD148B2C302J	RES. CARBON 3K 5% 1/6W
RO65	RD148B2C472J	RES. CARBON 4.7K 5% 1/6W
RO66	RD148B2C470J	RES. CARBON 47 5% 1/6W
RO67	RN148K2C2200F	RES. METAL FILM 220 1% 1/6W
RO68	RN148K2C3301F	RES. METAL FILM 3.3K 1% 1/6W
RO69	RN148K2C6800F	RES. METAL FILM 680 1% 1/6W
RO70	RD148B2C101J	RES. CARBON 100 5% 1/6W
RO71	RD148B2C470J	RES. CARBON 47 5% 1/6W
RO72	RD148B2C181J	RES. CARBON 180 5% 1/6W
RO73	RD148B2C102J	RES. CARBON 1K 5% 1/6W
RO74	RN148K2C1003F	RES. METAL FILM 100K 1% 1/6W
RO77	RN148K2C1003F	RES. METAL FILM 100K 1% 1/6W
RO78	RD148B2C103J	RES. CARBON 10K 5% 1/6W
RO79	RD148B2C472J	RES. CARBON 4.7K 5% 1/6W
RO80	RD148B2C361J	RES. CARBON 360 5% 1/6W
RO81	RD148B2C222J	RES. CARBON 2.2K 5% 1/6W
RO82	RD148B2C153J	RES. CARBON 15K 5% 1/6W
RO83	RD148B2C153J	RES. CARBON 15K 5% 1/6W
R101	RD148B2C331J	RES. CARBON 330 5% 1/6W
R102	RD148B2C751J	RES. CARBON 750 5% 1/6W
R103	RD148B2C391J	RES. CARBON 390 5% 1/6W
R104	RD148B2C103J	RES. CARBON 10K 5% 1/6W
R105	R90-0659-05	RES. NETWORK 4X510 5% 1/8W
R106	NO USE	
R107	RD148B2C105J	RES. CARBON 1M 5% 1/6W
R108	RD148B2C103J	RES. CARBON 10K 5% 1/6W
R109	R90-0660-05	RES. NETWORK 4X1K 5% 1/8W
R110	RD148B2C470J	RES. CARBON 47 5% 1/6W
R111	RD148B2C331J	RES. CARBON 330 5% 1/6W
R112	RD148B2C751J	RES. CARBON 750 5% 1/6W
R113	RD148B2C391J	RES. CARBON 390 5% 1/6W
R114	RD148B2C103J	RES. CARBON 10K 5% 1/6W
R115	R90-0659-05	RES. NETWORK 4X510 5% 1/8W
R116	RD148B2C470J	RES. CARBON 47 5% 1/6W
R117	R90-0660-05	RES. NETWORK 4X1K 5% 1/8W
R118	RD148B2C472J	RES. CARBON 4.7K 5% 1/6W
R119	RD148B2C472J	RES. CARBON 4.7K 5% 1/6W
R120	RD148B2C102J	RES. CARBON 1K 5% 1/6W
R121	RD148B2C102J	RES. CARBON 1K 5% 1/6W
R122	RD148B2C102J	RES. CARBON 1K 5% 1/6W
R123	RD148B2C470J	RES. CARBON 47 5% 1/6W
R124	RD148B2C101J	RES. CARBON 100 5% 1/6W
R125	RD148B2C331J	RES. CARBON 330 5% 1/6W
R126	RD148B2C242J	RES. CARBON 2.4K 5% 1/6W
R127	R90-0658-05	RES. NETWORK
R128	RD148B2C102J	RES. CARBON 1K 5% 1/6W
R129	RN148K2C8201F	RES. METAL FILM 8.2K 1% 1/6W
R130	RN148K2C1601F	RES. METAL FILM 1.6K 1% 1/6W
R131	RD148B2C242J	RES. CARBON 2.4K 5% 1/6W
R132	RD148B2C103J	RES. CARBON 10K 5% 1/6W
R133	RD148B2C103J	RES. CARBON 10K 5% 1/6W
R134	RD148B2C102J	RES. CARBON 1K 5% 1/6W
R135	RD148B2C241J	RES. CARBON 240 5% 1/6W
R136	RD148B2C152J	RES. CARBON 1.5K 5% 1/6W
R137	RD148B2C362J	RES. CARBON 3.6K 5% 1/6W
R138	RD148B2C561J	RES. CARBON 560 5% 1/6W
R139	RD148B2C471J	RES. CARBON 470 5% 1/6W

PARTS LIST

REF. NO	PARTS NO	NAME & DESCRIPTION	REF. NO	PARTS NO	NAME & DESCRIPTION
R140	RD148B2C162J	RES. CARBON 1.6K 5% 1/6W	R305	RD148B2C562J	RES. CARBON 5.6K 5% 1/6W
R141	RD148B2C182J	RES. CARBON 1.8K 5% 1/6W	R306	RD148B2C220J	RES. CARBON 22 5% 1/6W
R142	RD148B2C220J	RES. CARBON 22 5% 1/6W	R307	RD148B2C562J	RES. CARBON 5.6K 5% 1/6W
R143	RD148B2C103J	RES. CARBON 10K 5% 1/6W	R308	RD148B2C220J	RES. CARBON 22 5% 1/6W
R144	RD148B2C472J	RES. CARBON 4.7K 5% 1/6W	R309	RD148B2C152J	RES. CARBON 1.5K 5% 1/6W
R145	RD148B2C102J	RES. CARBON 1K 5% 1/6W	R310	NO USE	
R146	RD148B2C222J	RES. CARBON 2.2K 5% 1/6W	R311	RN148K2C3001F	RES. METAL FILM 3K 1% 1/6W
R147	RD148B2C242J	RES. CARBON 2.4K 5% 1/6W	R312	RN148K2C3601F	RES. METAL FILM 3.6K 1% 1/6W
R148	RN148K2C4701F	RES. METAL FILM 4.7K 1% 1/6W	R313	RN148K2C3601F	RES. METAL FILM 3.6K 1% 1/6W
R149	RN148K2C6801F	RES. METAL FILM 6.8K 1% 1/6W	R314	RD148B2C203J	RES. CARBON 20K 5% 1/6W
R150	RD148B2C470J	RES. CARBON 47 5% 1/6W	R315	RD148B2C273J	RES. CARBON 27K 5% 1/6W
R151	RD148B2C470J	RES. CARBON 47 5% 1/6W	R316	RD148B2C273J	RES. CARBON 27K 5% 1/6W
R152	RD148B2C102J	RES. CARBON 1K 5% 1/6W	R317	RD148B2C222J	RES. CARBON 2.2K 5% 1/6W
R153	RN148K2C4301F	RES. METAL FILM 4.3K 1% 1/6W	R318	RN148K2C2001F	RES. METAL FILM 2K 1% 1/6W
R154	RN148K2C1302F	RES. METAL FILM 1.3K 1% 1/6W	R319	RD148B2C222J	RES. CARBON 2.2K 5% 1/6W
R155	RD148B2C182J	RES. CARBON 1.8K 5% 1/6W	R320	RN148K2C7500F	RES. METAL FILM 750 1% 1/6W
R156	RD148B2C222J	RES. CARBON 2.2K 5% 1/6W	R321	RN148K2C4701F	RES. METAL FILM 4.7K 1% 1/6W
R157	RD148B2C563J	RES. CARBON 56K 5% 1/6W	R322	RN148K2C3301F	RES. METAL FILM 3.3K 1% 1/6W
R158	RD148B2C103J	RES. CARBON 10K 5% 1/6W	R323	RN148K2C1001F	RES. METAL FILM 1K 1% 1/6W
R159	RD148B2C102J	RES. CARBON 1K 5% 1/6W	R324	RN148K2C1001F	RES. METAL FILM 1K 1% 1/6W
R160	RD148B2C562J	RES. CARBON 5.6K 5% 1/6W	R325	RD148B2C164J	RES. CARBON 160K 5% 1/6W
R161	RD148B2C123J	RES. CARBON 12K 5% 1/6W	R326	RN148K2C1001F	RES. METAL FILM 1K 1% 1/6W
R162	RD148B2C182J	RES. CARBON 1.8K 5% 1/6W	R327	RN148K2C1001F	RES. METAL FILM 1K 1% 1/6W
R163	RD148B2C103J	RES. CARBON 10K 5% 1/6W	R328	RN148K2C131J	RES. CARBON 130 5% 1/6W
R164	RD148B2C103J	RES. CARBON 10K 5% 1/6W	R329	RD148B2C220J	RES. CARBON 22 5% 1/6W
R165	RD148B2C682J	RES. CARBON 6.8K 5% 1/6W	R330	RD148B2C220J	RES. CARBON 22 5% 1/6W
R166	RD148B2C222J	RES. CARBON 2.2K 5% 1/6W	R331	RD148B2C272J	RES. CARBON 2.7K 5% 1/6W
R167	RD148B2C100J	RES. CARBON 10 5% 1/6W	R332	RD148B2C302J	RES. CARBON 3K 5% 1/6W
R168	RD148B2C681J	RES. CARBON 680 5% 1/6W	R333	RD148B2C202J	RES. CARBON 2K 5% 1/6W
R169	RD148B2C470J	RES. CARBON 47 5% 1/6W	R334	RN148K2C1002F	RES. METAL FILM 10K 1% 1/6W
R170	RD148B2C272J	RES. CARBON 2.7K 5% 1/6W	R335	RN148K2C5602F	RES. METAL FILM 56K 1% 1/6W
R171	RD148B2C470J	RES. CARBON 47 5% 1/6W	R336	RN148K2C1502F	RES. METAL FILM 15K 1% 1/6W
R172	RD148B2C471J	RES. CARBON 470 5% 1/6W	R337	RD148B2C472J	RES. CARBON 4.7K 5% 1/6W
R173	RD148B2C271J	RES. CARBON 270 5% 1/6W	R338	NO USE	
R174	RD148B2C162J	RES. CARBON 1.6K 5% 1/6W	R339	RD148B2C102J	RES. CARBON 1K 5% 1/6W
R175	RD148B2C472J	RES. CARBON 4.7K 5% 1/6W	R340	RD148B2C471J	RES. CARBON 470 5% 1/6W
R176	RD148B2C224J	RES. CARBON 220K 5% 1/6W	R341	RD148B2C102J	RES. CARBON 1K 5% 1/6W
R177	RD148B2C821J	RES. CARBON 820 5% 1/6W	R342	R90-0660-05	RES. NETWORK 4X1K 5% 1/8W
R178	RD148B2C681J	RES. CARBON 680 5% 1/6W	R343	RN148K2C1001F	RES. METAL FILM 1K 1% 1/6W
R179	RD148B2C752J	RES. CARBON 7.5K 5% 1/6W	R344	RN148K2C2200F	RES. METAL FILM 220 1% 1/6W
R180	RD148B2C182J	RES. CARBON 1.8K 5% 1/6W	R345	RN148K2C5601F	RES. METAL FILM 5.6K 1% 1/6W
R181	RN148K2C1102F	RES. METAL FILM 11K 1% 1/6W	R346	RD148B2C470J	RES. CARBON 47 5% 1/6W
R182	RD148B2C202J	RES. CARBON 2K 5% 1/6W	R347	RD148B2C104J	RES. CARBON 100K 5% 1/6W
R183	RN148K2C1202F	RES. METAL FILM 12K 1% 1/6W	R348	RD148B2C104J	RES. CARBON 100K 5% 1/6W
R184	RD148B2C470J	RES. CARBON 47 5% 1/6W	R349	RN148K2C2001F	RES. METAL FILM 2K 1% 1/6W
R185	RD148B2C101J	RES. CARBON 100 5% 1/6W	R350	RN148K2C1801F	RES. METAL FILM 1.8K 1% 1/6W
R186	RD148B2C622J	RES. CARBON 6.2K 5% 1/6W	R351	RN148K2C2702F	RES. METAL FILM 27K 1% 1/6W
R187	RD148B2C471J	RES. CARBON 470 5% 1/6W	R352	RD148B2C243J	RES. CARBON 24K 5% 1/6W
R191	RD148B2C102J	RES. CARBON 1K 5% 1/6W	R353	RD148B2C243J	RES. CARBON 24K 5% 1/6W
R192	RD148B2C101J	RES. CARBON 100 5% 1/6W	R354	RD148B2C243J	RES. CARBON 24K 5% 1/6W
R193	RD148B2C101J	RES. CARBON 100 5% 1/6W	R355	RN148K2C3301F	RES. METAL FILM 3.3K 1% 1/6W
R194	RD148B2C331J	RES. CARBON 330 5% 1/6W	R356	RN148K2C4701F	RES. METAL FILM 4.7K 1% 1/6W
R195	R90-0658-05	RES. NETWORK	R357	RD148B2C332J	RES. CARBON 3.3K 5% 1/6W
R196	RD148B2C123J	RES. CARBON 12K 5% 1/6W	R358	RD148B2C202J	RES. CARBON 2K 5% 1/6W
R197	RN148K2C8201F	RES. METAL FILM 8.2K 1% 1/6W	R359	RD148B2C220J	RES. CARBON 22 5% 1/6W
R198	RN148K2C1601F	RES. METAL FILM 1.6K 1% 1/6W	R360	RD148B2C242J	RES. CARBON 2.4K 5% 1/6W
R199	RD148B2C242J	RES. CARBON 2.4K 5% 1/6W	R361	RD148B2C472J	RES. CARBON 4.7K 5% 1/6W
R200	RD148B2C103J	RES. CARBON 10K 5% 1/6W	R364	RD148B2C222J	RES. CARBON 2.2K 5% 1/6W
R201	RD148B2C103J	RES. CARBON 10K 5% 1/6W	R365	RD148B2C101J	RES. CARBON 100 5% 1/6W
R202	RD148B2C102J	RES. CARBON 1K 5% 1/6W	R366	RD148B2C473J	RES. CARBON 47K 5% 1/6W
R203	RD148B2C241J	RES. CARBON 240 5% 1/6W	R367	RD148B2C222J	RES. CARBON 2.2K 5% 1/6W
R204	RD148B2C152J	RES. CARBON 1.5K 5% 1/6W	R368	RN148K2C1602F	RES. METAL FILM 16K 1% 1/6W
R205	RD148B2C362J	RES. CARBON 3.6K 5% 1/6W	R369	RN148K2C6800F	RES. METAL FILM 680 1% 1/6W
R206	RD148B2C561J	RES. CARBON 560 5% 1/6W	R370	RD148B2C101J	RES. CARBON 100 5% 1/6W
R207	RD148B2C471J	RES. CARBON 470 5% 1/6W	R371	RD148B2C102J	RES. CARBON 1K 5% 1/6W
R208	RD148B2C162J	RES. CARBON 1.6K 5% 1/6W	R372	RD148B2C102J	RES. CARBON 1K 5% 1/6W
R209	RD148B2C182J	RES. CARBON 1.8K 5% 1/6W	R373	RD148B2C682J	RES. CARBON 6.8K 5% 1/6W
R210	RD148B2C220J	RES. CARBON 22 5% 1/6W	R374	RD148B2C912J	RES. CARBON 9.1K 5% 1/6W
R211	RD148B2C103J	RES. CARBON 10K 5% 1/6W	R401	RD148B2C103J	RES. CARBON 10K 5% 1/6W
R212	RD148B2C472J	RES. CARBON 4.7K 5% 1/6W	R402	RD148B2C102J	RES. CARBON 1K 5% 1/6W
R213	RD148B2C102J	RES. CARBON 1K 5% 1/6W	R403	NO USE	
R214	RD148B2C470J	RES. CARBON 47 5% 1/6W	R404	RD148B2C512J	RES. CARBON 5.1K 5% 1/6W
R215	RD148B2C470J	RES. CARBON 47 5% 1/6W	R405	RD148B2C752J	RES. CARBON 7.5K 5% 1/6W
R216	RD148B2C102J	RES. CARBON 1K 5% 1/6W	R406	RD148B2C432J	RES. CARBON 4.3K 5% 1/6W
R217	RN148K2C4301F	RES. METAL FILM 4.3K 1% 1/6W	R407	RD148B2C102J	RES. CARBON 1K 5% 1/6W
R218	RN148K2C1302F	RES. METAL FILM 1.3K 1% 1/6W	R408	RD148B2C103J	RES. CARBON 10K 5% 1/6W
R219	RD148B2C182J	RES. CARBON 1.8K 5% 1/6W	R409	RD148B2C273J	RES. CARBON 27K 5% 1/6W
R220	RD148B2C222J	RES. CARBON 2.2K 5% 1/6W	R410	RD148B2C102J	RES. CARBON 1K 5% 1/6W
R221	RD148B2C470J	RES. CARBON 47 5% 1/6W	R411	RD148B2C222J	RES. CARBON 2.2K 5% 1/6W
R222	RD148B2C222J	RES. CARBON 2.2K 5% 1/6W	R412	RD148B2C102J	RES. CARBON 1K 5% 1/6W
R223	RD148B2C222J	RES. CARBON 2.2K 5% 1/6W	R413	RD148B2C101J	RES. CARBON 100 5% 1/6W
R224	RD148B2C272J	RES. CARBON 2.7K 5% 1/6W	R414	NO USE	
R225	RD148B2C272J	RES. CARBON 2.7K 5% 1/6W	R415	RD148B2C102J	RES. CARBON 1K 5% 1/6W
R226	RD148B2C123J	RES. CARBON 12K 5% 1/6W	R416	RD148B2C222J	RES. CARBON 2.2K 5% 1/6W
R227	RD148B2C223J	RES. CARBON 22K 5% 1/6W	R417	RD148B2C222J	RES. CARBON 2.2K 5% 1/6W
R228	RD148B2C105J	RES. CARBON 1M 5% 1/6W	R418	RD148B2C472J	RES. CARBON 4.7K 5% 1/6W
R229	RD148B2C105J	RES. CARBON 1M 5% 1/6W	R419	RD148B2C331J	RES. CARBON 330 5% 1/6W
R301	RD148B2C152J	RES. CARBON 1.5K 5% 1/6W	R420	RD148B2C102J	RES. CARBON 1K 5% 1/6W
R302	RD148B2C222J	RES. CARBON 2.2K 5% 1/6W	R421	RD148B2C102J	RES. CARBON 1K 5% 1/6W

PARTS LIST

REF.NO	PARTS NO	NAME & DESCRIPTION	RES.	100	5%	1/6W
R422	RD14BB2C101J	RES. CARBON	100	5%	1/6W	
R423	RD14BB2C471J	RES. CARBON	470	5%	1/6W	
R600	RD14BB2C393J	RES. CARBON	39K	5%	1/6W	
R601	RD14BB2C220J	RES. CARBON	22	5%	1/6W	
R602	RD14BB2C220J	RES. CARBON	22	5%	1/6W	
TC101	C05-0446-05	CAP. TRIMMER	30P			
TC102	C05-0446-05	CAP. TRIMMER	30P			
TC302	C05-0468-05	CAP. TRIMMER	7P			
TC303	C05-0468-05	CAP. TRIMMER	7P			
U001	MC10H102L	IC, QUAD 2-INPUT NOR GATE				
U002	MC10H102L	IC, QUAD 2-INPUT NOR GATE				
U003	MC10H131L	IC, DUAL D-FLIP FLOP				
U004	MC10103L	IC, QUAD 2-INPUT OR GATE				
U005	SN74ALS74AN	IC, DUAL D-F.F.(WITH PR & CLR)				
U006	SN74ALS74AN	IC, DUAL D-F.F.(WITH PR & CLR)				
U007	SN74ALS74AN	IC, DUAL D-F.F.(WITH PR & CLR)				
U011	SN74ALS02N	IC, QUAD 2 INPUT NOR				
U012	SN74ALS32N	IC, QUAD 2 INPUT OR				
U013	SN74ALS08N	IC, QUAD 2 INPUT AND				
U014	SN74ALS32N	IC, QUAD 2 INPUT OR				
U015	SN74ALS02N	IC, QUAD 2 INPUT NOR				
U016	MC14052BCP	IC, DUAL 4-CH ANALOG MPX/DE-MPX				
U017	MC14052BCP	IC, DUAL 4-CH ANALOG MPX/DE-MPX				
U018	MC14052BCP	IC, DUAL 4-CH ANALOG MPX/DE-MPX				
U019	MC74HC4053AN	IC, TRIPLE 2CH ANALOG MPX/DE-MP				
U020	NO USE					
U021	NJM072S	IC, J-FET INPUT OP AMP				
U022	NJM072S	IC, J-FET INPUT OP AMP				
U023	NO USE					
U024	NJM072S	IC, J-FET INPUT OP AMP				
U025	NJM072S	IC, J-FET INPUT OP AMP				
U026	NJM072S	IC, J-FET INPUT OP AMP				
U027	NJM072S	IC, J-FET INPUT OP AMP				
U028	HD74HC595AP	IC, 8-BIT SHIFT REGISTER/LATCH				
U029	HD74HC595AP	IC, 8-BIT SHIFT REGISTER/LATCH				
U030	HD74HC595AP	IC, 8-BIT SHIFT REGISTER/LATCH				
U031	HD74HC595AP	IC, 8-BIT SHIFT REGISTER/LATCH				
U032	HD74HC595AP	IC, 8-BIT SHIFT REGISTER/LATCH				
U101	2SK332(E)	FET, N-CHANNEL				
U102	2SC3066(F)	TR, SI, NPN				
U103	2SK332(E)	FET, N-CHANNEL				
VR001	R12-3543-05	RES. SEMI FIXED 20KB				
VR002	NO USE					
VR003	R12-0571-05	RES. SEMI FIXED 500B				
VR004	R12-3543-05	RES. SEMI FIXED 20KB				
VR101	R12-1538-05	RES. SEMI FIXED 1KB				
VR102	R12-2520-05	RES. SEMI FIXED 5KB				
VR103	R12-3543-05	RES. SEMI FIXED 20KB				
VR104	R12-3543-05	RES. SEMI FIXED 20KB				
VR301	R12-1539-05	RES. SEMI FIXED 2KB				
VR302	R12-1539-05	RES. SEMI FIXED 2KB				
VR303	R12-0571-05	RES. SEMI FIXED 500B				
VR304	R12-3453-05	RES. SEMI FIXED 10KB				
VR305	R12-3453-05	RES. SEMI FIXED 10KB				
VR306	R12-3453-05	RES. SEMI FIXED 10KB				
VR307	R12-0569-05	RES. SEMI FIXED 100B				

VERTICAL ATTENUATOR UNIT

X75-1180-00

REF.NO	PARTS NO	NAME & DESCRIPTION	RES.	100	5%	1/6W
	J25-5230-03	PCB (UNMOUNTED)				
74	E04-0260-05	BNC RECEPTACLE (READOUT)				
75	J21-4612-14	BRACKET, FOR BNC				
76	J30-0623-04	SPACER				
C001	CE04EW1C471M	CAP. ELECTRO	470	20%	16V	
C002	CE04EW1G471M	CAP. ELECTRO	470	20%	16V	
C003	CE04EW1A221M	CAP. ELECTRO	220	20%	10V	
C004	CE04EW1A221M	CAP. ELECTRO	220	20%	10V	
C005	CK45FF1H103Z	CAP. CERAMIC	0.01		50V	
C006	CK45FF1H103Z	CAP. CERAMIC	0.01		50V	
C007	CK45FF1H103Z	CAP. CERAMIC	0.01		50V	
C008	CK45FF1H103Z	CAP. CERAMIC	0.01		50V	
C009	CK45FF1H103Z	CAP. CERAMIC	0.01		50V	
C010	CK45FF1H103Z	CAP. CERAMIC	0.01		50V	
C011	CK45FF1H103Z	CAP. CERAMIC	0.01		50V	
C012	CK45FF1H103Z	CAP. CERAMIC	0.01		50V	
C013	CK45FF1H103Z	CAP. CERAMIC	0.01		50V	
C014	CK45FF1H103Z	CAP. CERAMIC	0.01		50V	
C015	CK45FF1H103Z	CAP. CERAMIC	0.01		50V	
C016	CK45FF1H103Z	CAP. CERAMIC	0.01		50V	
C017	CK45FF1H103Z	CAP. CERAMIC	0.01		50V	
C018	CK45FF1H103Z	CAP. CERAMIC	0.01		50V	
C019	CK45FF1H103Z	CAP. CERAMIC	0.01		50V	
C020	CK45FF1H103Z	CAP. CERAMIC	0.01		50V	
C101	C91-0502-05	CAP. METAL FILM	0.01	20%	630V	
C102	NO USE					
C103	CE04EW1C330M	CAP. ELECTRO	33	20%	16V	
C104	CC45CH1H101J	CAP. CERAMIC	100P	5%	50V	
C105	NO USE					
C106	CC45FCH1H330J	CAP. CERAMIC	33P	5%	50V	
C107	CC45FCH1H470J	CAP. CERAMIC	47P	5%	50V	
C201	C91-0502-05	CAP. METAL FILM	0.01	20%	630V	
C202	NO USE					
C203	CE04EW1C330M	CAP. ELECTRO	33	20%	16V	
C204	CC45CH1H101J	CAP. CERAMIC	100P	5%	50V	
C205	NO USE					
C206	CC45FCH1H330J	CAP. CERAMIC	33P	5%	50V	
C207	CC45FCH1H470J	CAP. CERAMIC	47P	5%	50V	
C301	CC45CH2H050C	CAP. CERAMIC	5P	0.25P	500V	
C302	C91-0502-05	CAP. METAL FILM	0.01	20%	630V	
C303	NO USE					
C304	CC45FCH1H030C	CAP. CERAMIC	3P	0.25P	50V	
C305	CC45CH2H080D	CAP. CERAMIC	8P	0.5P	500V	
C306	NO USE					
C307	CK45FB1H102K	CAP. CERAMIC	1000P	10%	50V	
C350	CC45CH1H180J	CAP. CERAMIC	18P	5%	50V	
C351	CC45CH1H220J	CAP. CERAMIC	22P	5%	50V	
C401	CC45CH2H050C	CAP. CERAMIC	5P	0.25P	500V	
C402	C91-0502-05	CAP. METAL FILM	0.01	20%	630V	
C403	NO USE					
C404	CC45FCH1H030C	CAP. CERAMIC	3P	0.25P	50V	
C405	CC45CH2H080D	CAP. CERAMIC	8P	0.5P	500V	
C406	NO USE					
C407	CK45FB1H102K	CAP. CERAMIC	1000P	10%	50V	
C450	CC45CH1H180J	CAP. CERAMIC	18P	5%	50V	
C451	CC45CH1H220J	CAP. CERAMIC	22P	5%	50V	
D001	1SS132	DIODE				
D002	1SS132	DIODE				
D101	1SS132	DIODE				
D102	1SS132	DIODE				
D201	1SS132	DIODE				
D202	1SS132	DIODE				
D301	1SS132	DIODE				
D302	1SS132	DIODE				
D303	1SS135	DIODE				
D401	1SS132	DIODE				
D402	1SS132	DIODE				
D403	1SS135	DIODE				
JW005	E31-5578-05	LEAD WIRE WITH CONNECTOR				
JW006	E31-5579-05	LEAD WIRE WITH CONNECTOR				

PARTS LIST

REF.NO	PARTS NO	NAME & DESCRIPTION
K301	S51-2508-05	RELAY
K401	S51-2508-05	RELAY
L001	L40-1011-03	FERRI INDUCTOR 100UH
P004	E40-0973-05	PIN CONNECTOR 9P
P007	E40-0473-05	PIN CONNECTOR 4P
P008	E40-0473-05	PIN CONNECTOR 4P
P009	E40-0373-05	PIN CONNECTOR 3P
Q001	2SA1565	TR. SI, PNP
Q002	2SA1565	TR. SI, PNP
Q101	2SC3354(T,S)	TR. SI, NPN
Q102	2SC3394(T,S)	TR. SI, NPN
Q201	2SC3354(T,S)	TR. SI, NPN
Q202	2SC3354(T,S)	TR. SI, NPN
Q301	2SK241(GR)	FET, N-CHANNEL
Q302	2SK241(GR)	FET, N-CHANNEL
Q303	2SC3354(T,S)	TR. SI, NPN
Q304	2SC3779(D)	TR. SI, NPN
Q305	2SC3779(D)	TR. SI, NPN
Q306	2SC3354(T,S)	TR. SI, NPN
Q401	2SK241(GR)	FET, N-CHANNEL
Q402	2SK241(GR)	FET, N-CHANNEL
Q403	2SC3354(T,S)	TR. SI, NPN
Q404	2SC3779(D)	TR. SI, NPN
Q405	2SC3779(D)	TR. SI, NPN
Q406	2SC3354(T,S)	TR. SI, NPN
R001	RD14BB2C100J	RES. CARBON 10 5% 1/6W
R002	RD14BB2C100J	RES. CARBON 10 5% 1/6W
R003	RD14BB2C102J	RES. CARBON 1K 5% 1/6W
R004	RD14BB2C102J	RES. CARBON 1K 5% 1/6W
R005	RD14BB2C102J	RES. CARBON 1K 5% 1/6W
R006	RD14BB2C102J	RES. CARBON 1K 5% 1/6W
R007	RD14BB2C101J	RES. CARBON 100 5% 1/6W
R008	RD14BB2C101J	RES. CARBON 100 5% 1/6W
R009	RD14BB2C101J	RES. CARBON 100 5% 1/6W
R101	RN14BK2E1004D	RES. METAL FILM 1M 0.5% 1/4W
R102	RD14BB2C824J	RES. CARBON 820K 5% 1/6W
R103	RN14BK2C62R0F	RES. METAL FILM 62.0 1% 1/6W
R104	RN14BK2C62R0F	RES. METAL FILM 62.0 1% 1/6W
R105	R92-1431-05	RES. TEMP. COEFF. 330 5% 1/6W
R106	RN14BK2C5100F	RES. METAL FILM 510 1% 1/6W
R107	RN14BK2C1003F	RES. METAL FILM 100K 1% 1/6W
R108	RN14BK2C1000F	RES. METAL FILM 100 1% 1/6W
R109	RN14BK2C1000F	RES. METAL FILM 100 1% 1/6W
R110	RD14BB2C221J	RES. CARBON 220 5% 1/6W
R111	RD14BB2C181J	RES. CARBON 180 5% 1/6W
R112	NO USE	
R113	RN14BK2C4300F	RES. METAL FILM 430 1% 1/6W
R114	RN14BK2C4301F	RES. METAL FILM 4.3K 1% 1/6W
R115	RN14BK2C3601F	RES. METAL FILM 3.6K 1% 1/6W
R116	RN14BK2C2401F	RES. METAL FILM 2.4K 1% 1/6W
R117	RN14BK2C7501F	RES. METAL FILM 7.5K 1% 1/6W
R118	RN14BK2C1501F	RES. METAL FILM 1.5K 1% 1/6W
R119	RN14BK2C7501F	RES. METAL FILM 7.5K 1% 1/6W
R120	RN14BK2C1001F	RES. METAL FILM 1K 1% 1/6W
R121	RN14BK2C1001F	RES. METAL FILM 1K 1% 1/6W
R122	RD14BB2C220J	RES. CARBON 22 5% 1/6W
R123	RD14BB2C220J	RES. CARBON 22 5% 1/6W
R124	NO USE	
R125	RD14BB2C220J	RES. CARBON 22 5% 1/6W
R126	RD14BB2C220J	RES. CARBON 22 5% 1/6W
R127	RN14BK2C3000F	RES. METAL FILM 300 1% 1/6W
R128	RN14BK2C3300F	RES. METAL FILM 330 1% 1/6W
R150	RD14BB2C220J	RES. CARBON 22 5% 1/6W
R201	RN14BK2E1004D	RES. METAL FILM 1M 0.5% 1/4W
R202	RD14BB2C824J	RES. CARBON 820K 5% 1/6W
R203	RN14BK2C62R0F	RES. METAL FILM 62.0 1% 1/6W
R204	RN14BK2C62R0F	RES. METAL FILM 62.0 1% 1/6W
R205	R92-1431-05	RES. TEMP. COEFF. 330 5% 1/6W
R206	RN14BK2C5100F	RES. METAL FILM 510 1% 1/6W
R207	RN14BK2C1003F	RES. METAL FILM 100K 1% 1/6W
R208	RN14BK2C1000F	RES. METAL FILM 100 1% 1/6W
R209	RN14BK2C1000F	RES. METAL FILM 100 1% 1/6W
R210	RD14BB2C221J	RES. CARBON 220 5% 1/6W
R211	RD14BB2C181J	RES. CARBON 180 5% 1/6W
R212	NO USE	
R213	RN14BK2C4300F	RES. METAL FILM 430 1% 1/6W
R214	RN14BK2C4301F	RES. METAL FILM 4.3K 1% 1/6W
R215	RN14BK2C3601F	RES. METAL FILM 3.6K 1% 1/6W

REF.NO	PARTS NO	NAME & DESCRIPTION
R216	RN14BK2C2401F	RES. METAL FILM 2.4K 1% 1/6W
R217	RN14BK2C7501F	RES. METAL FILM 7.5K 1% 1/6W
R218	RN14BK2C2401F	RES. METAL FILM 2.4K 1% 1/6W
R219	RN14BK2C7501F	RES. METAL FILM 7.5K 1% 1/6W
R220	RN14BK2C1001F	RES. METAL FILM 1K 1% 1/6W
R221	RN14BK2C1001F	RES. METAL FILM 1K 1% 1/6W
R222	RD14BB2C220J	RES. CARBON 22 5% 1/6W
R223	RD14BB2C220J	RES. CARBON 22 5% 1/6W
R224	RD14BB2C682J	RES. CARBON 6.8K 5% 1/6W
R225	RD14BB2C220J	RES. CARBON 22 5% 1/6W
R226	RD14BB2C220J	RES. CARBON 22 5% 1/6W
R227	RN14BK2C3000F	RES. METAL FILM 300 1% 1/6W
R228	RN14BK2C3300F	RES. METAL FILM 330 1% 1/6W
R250	RD14BB2C220J	RES. CARBON 22 5% 1/6W
R301	RD14BB2E330J	RES. CARBON 33 5% 1/4W
R302	RD14BB2C560J	RES. CARBON 56 5% 1/6W
R303	R92-1433-05	RES. METAL FILM 800K 0.5% 1/2W
R304	R92-1432-05	RES. METAL FILM 250K 0.5% 1/2W
R305	RD14BB2C240J	RES. CARBON 24 5% 1/6W
R306	RN14BK2E1004D	RES. METAL FILM 1M 0.5% 1/4W
R307	RD14BB2C684J	RES. CARBON 680K 5% 1/6W
R308	RD14BB2C101J	RES. CARBON 100 5% 1/6W
R309	RD14BB2C201J	RES. CARBON 200 5% 1/6W
R310	RN14BK2C3900F	RES. METAL FILM 390 1% 1/6W
R311	RN14BK2C3900F	RES. METAL FILM 390 1% 1/6W
R312	RD14BB2C220J	RES. CARBON 22 5% 1/6W
R313	RD14BB2C510J	RES. CARBON 51 5% 1/6W
R314	RN14BK2C3601F	RES. METAL FILM 3.6K 1% 1/6W
R315	RN14BK2C3901F	RES. METAL FILM 3.9K 1% 1/6W
R316	RN14BK2C3900F	RES. METAL FILM 390 1% 1/6W
R317	NO USE	
R318	RD14BB2C510J	RES. CARBON 51 5% 1/6W
R319	RD14BB2C820J	RES. CARBON 82 5% 1/6W
R320	RD14BB2C220J	RES. CARBON 22 5% 1/6W
R350	RD14BB2C221J	RES. CARBON 220 5% 1/6W
R401	RD14BB2E330J	RES. CARBON 33 5% 1/4W
R402	RD14BB2C560J	RES. CARBON 56 5% 1/6W
R403	R92-1433-05	RES. METAL FILM 800K 0.5% 1/2W
R404	R92-1432-05	RES. METAL FILM 250K 0.5% 1/2W
R405	RD14BB2C240J	RES. CARBON 24 5% 1/6W
R406	RN14BK2E1004D	RES. METAL FILM 1M 0.5% 1/4W
R407	RD14BB2C684J	RES. CARBON 680K 5% 1/6W
R408	RD14BB2C101J	RES. CARBON 100 5% 1/6W
R409	RD14BB2C201J	RES. CARBON 200 5% 1/6W
R410	RN14BK2C3900F	RES. METAL FILM 390 1% 1/6W
R411	RN14BK2C3900F	RES. METAL FILM 390 1% 1/6W
R412	RD14BB2C220J	RES. CARBON 22 5% 1/6W
R413	RD14BB2C510J	RES. CARBON 51 5% 1/6W
R414	RN14BK2C3601F	RES. METAL FILM 3.6K 1% 1/6W
R415	RN14BK2C3901F	RES. METAL FILM 3.9K 1% 1/6W
R416	RN14BK2C3900F	RES. METAL FILM 390 1% 1/6W
R417	NO USE	
R418	RD14BB2C510J	RES. CARBON 51 5% 1/6W
R419	RD14BB2C820J	RES. CARBON 82 5% 1/6W
R420	RD14BB2C220J	RES. CARBON 22 5% 1/6W
R450	RD14BB2C221J	RES. CARBON 220 5% 1/6W
S101	S02-4511-15	ATTENUATOR UNIT
S201	S02-4511-15	ATTENUATOR UNIT
TC101	C05-0459-05	CAP. TRIMMER 10P
TC201	C05-0459-05	CAP. TRIMMER 10P
TC301	C05-0031-15	CAP. TRIMMER 10P
TC302	C05-0031-15	CAP. TRIMMER 10P
TC401	C05-0031-15	CAP. TRIMMER 10P
TC402	C05-0031-15	CAP. TRIMMER 10P
U001	HD74HC595P	IC, 8-BIT SHIFT REGISTER/LATCH
U002	HD74HC595P	IC, 8-BIT SHIFT REGISTER/LATCH
U101	DN1901	FET, DUAL, N-CHANNEL
U102	UPA101G	IC, NPN TRANSISTOR ARRAY
U201	DN1901	FET, DUAL, N-CHANNEL
U202	UPA101G	IC, NPN TRANSISTOR ARRAY
VR101	R12-3543-05	RES. SEMI FIXED 20KB
VR201	R12-3543-05	RES. SEMI FIXED 20KB

PARTS LIST

R/O UNIT

X77-1490-00

REF. NO	PARTS NO	NAME & DESCRIPTION
	J25-5231-02	PCB (UNMOUNTED)
	W09-0408-05	BATTERY, CR2354-1HF
C001	C092FM1H104K	CAP. MYLAR 0.1 10% 50V
C002	C092FM1H104K	CAP. MYLAR 0.1 10% 50V
C003	CC45FCH1H101J	CAP. CERAMIC 100P 5% 50V
C004	C092FM1H104K	CAP. MYLAR 0.1 10% 50V
C005	CC45FCH1H101J	CAP. CERAMIC 100P 5% 50V
C006	C092FM1H104K	CAP. MYLAR 0.1 10% 50V
C007	C092FM1H104K	CAP. MYLAR 0.1 10% 50V
C008	C092FM1H104K	CAP. MYLAR 0.1 10% 50V
C009	C092FM1H104K	CAP. MYLAR 0.1 10% 50V
C010	C092FM1H104K	CAP. MYLAR 0.1 10% 50V
C011	C092FM1H104K	CAP. MYLAR 0.1 10% 50V
C012	C092FM1H104K	CAP. MYLAR 0.1 10% 50V
C013	C092FM1H104K	CAP. MYLAR 0.1 10% 50V
C014	C092FM1H104K	CAP. MYLAR 0.1 10% 50V
C015	C092FM1H104K	CAP. MYLAR 0.1 10% 50V
C016	C092FM1H104K	CAP. MYLAR 0.1 10% 50V
C017	CC45FCH1H220J	CAP. CERAMIC 22P 5% 50V
C018	CC45FCH1H220J	CAP. CERAMIC 22P 5% 50V
C019	CE04EW1C220M	CAP. ELECTRO 22 20% 16V
C020	C092FM1H104K	CAP. MYLAR 0.1 10% 50V
C021	C092FM1H104K	CAP. MYLAR 0.1 10% 50V
C022	C092FM1H104K	CAP. MYLAR 0.1 10% 50V
C023	C092FM1H104K	CAP. MYLAR 0.1 10% 50V
C024	C092FM1H104K	CAP. MYLAR 0.1 10% 50V
C025	C092FM1H104K	CAP. MYLAR 0.1 10% 50V
C026	C092FM1H104K	CAP. MYLAR 0.1 10% 50V
C027	C092FM1H104K	CAP. MYLAR 0.1 10% 50V
C028	C092FM1H104K	CAP. MYLAR 0.1 10% 50V
C029	C092FM1H104K	CAP. MYLAR 0.1 10% 50V
C030	C092FM1H104K	CAP. MYLAR 0.1 10% 50V
C031	C092FM1H104K	CAP. MYLAR 0.1 10% 50V
C032	C092FM1H104K	CAP. MYLAR 0.1 10% 50V
C033	C91-0769-05	CAP. AXIAL 0.01 20% 16V
C034	CC45FCH1H101J	CAP. CERAMIC 100P 5% 50V
C035	C092FM1H104K	CAP. MYLAR 0.1 10% 50V
C036	CE04EW1C220M	CAP. ELECTRO 22 20% 16V
C037	CK45F1H103Z	CAP. CERAMIC 0.01 50V
C038	CC45FCH1H101J	CAP. CERAMIC 100P 5% 50V
C039	CE04EW1E331M	CAP. ELECTRO 330 20% 16V
C040	CK45F1H103Z	CAP. CERAMIC 0.01 50V
C041	CE04EW1E470M	CAP. ELECTRO 47 20% 25V
C042	CC45FSL1H471J	CAP. CERAMIC 470P 5% 50V
C043	CE04EW1A471M	CAP. ELECTRO 470 20% 10V
C044	C092FM1H104K	CAP. MYLAR 0.1 10% 50V
C045	C092FM1H104K	CAP. MYLAR 0.1 10% 50V
C046	C092FM1H104K	CAP. MYLAR 0.1 10% 50V
C047	C092FM1H104K	CAP. MYLAR 0.1 10% 50V
C048	C092FM1H104K	CAP. MYLAR 0.1 10% 50V
C049	C092FM1H104K	CAP. MYLAR 0.1 10% 50V
C050	C092FM1H104K	CAP. MYLAR 0.1 10% 50V
C051	C092FM1H104K	CAP. MYLAR 0.1 10% 50V
C052	C092FM1H104K	CAP. MYLAR 0.1 10% 50V
C053	C092FM1H104K	CAP. MYLAR 0.1 10% 50V
C054	C092FM1H104K	CAP. MYLAR 0.1 10% 50V
C055	CC45FCH1H101J	CAP. CERAMIC 100P 5% 50V
C056	C092FM1H104K	CAP. MYLAR 0.1 10% 50V
C057	C092FM1H104K	CAP. MYLAR 0.1 10% 50V
C058	C092FM1H104K	CAP. MYLAR 0.1 10% 50V
C059	C092FM1H104K	CAP. MYLAR 0.1 10% 50V
C060	CK45F1H103Z	CAP. CERAMIC 0.01 50V
C061	CK45F1H103Z	CAP. CERAMIC 0.01 50V
C062	C092FM1H104K	CAP. MYLAR 0.1 10% 50V
C063	C092FM1H104K	CAP. MYLAR 0.1 10% 50V
C064	CK45F1H103Z	CAP. CERAMIC 0.01 50V
C065	CK45F1H103Z	CAP. CERAMIC 0.01 50V
C066	C092FM1H104K	CAP. MYLAR 0.1 10% 50V
C067	C092FM1H104K	CAP. MYLAR 0.1 10% 50V
C068	C092FM1H104K	CAP. MYLAR 0.1 10% 50V
C069	C092FM1H104K	CAP. MYLAR 0.1 10% 50V
C070	CK45F1H103Z	CAP. CERAMIC 0.01 50V
C071	CC45FCH1H101J	CAP. CERAMIC 100P 5% 50V
C072	CK45F1H103Z	CAP. CERAMIC 0.01 50V
C073	CK45F1H103Z	CAP. CERAMIC 0.01 50V
C074	CK45F1H103Z	CAP. CERAMIC 0.01 50V
C075	C092FM1H104K	CAP. MYLAR 0.1 10% 50V
C076	CE04EW1C470M	CAP. ELECTRO 47 20% 16V
C077	CE04EW1C471M	CAP. ELECTRO 470 20% 16V
C078	CE04EW1C471M	CAP. ELECTRO 470 20% 16V
C079	C91-1273-05	CAP. NETWORK 6X0.01U 50V
C080	CE04EW1A102M	CAP. ELECTRO 1000 20% 10V
C081	NO USE	
C082	CK45FB1H102K	CAP. CERAMIC 1000P 10% 50V
C086	C092FM1H104K	CAP. MYLAR 0.1 10% 50V
C087	C092FM1H104K	CAP. MYLAR 0.1 10% 50V

REF. NO	PARTS NO	NAME & DESCRIPTION
D001	1SS132	DIODE
D002	1SS132	DIODE
D003	1SS132	DIODE
D004	1SS132	DIODE
D005	MTZ12JC	DIODE ZENER 12.05V
D006	1SS132	DIODE
D007	1SS132	DIODE
L001	L40-1011-03	FERRI INDUCTOR 100UH
L002	L40-1021-03	FERRI INDUCTOR 1MH
L003	L40-1092-03	FERRI INDUCTOR 1UH
L004	L40-1011-03	FERRI INDUCTOR 100UH
P001	E40-7036-05	PIN CONNECTOR 20P
P002	E40-7037-05	SOCKET 26P
P003	E40-7035-05	SOCKET 40P
P004	E40-0973-05	PIN CONNECTOR 9P
Q001	2SA1175(F)	TR. SI, PNP
Q002	2SC1384(R,S)	TR. SI, NPN
R001	RD14BB2C102J	RES. CARBON 1K 5% 1/6W
R002	RD14BB2C101J	RES. CARBON 100 5% 1/6W
R003	RD14BB2C472J	RES. CARBON 4.7K 5% 1/6W
R004	RD14BB2C222J	RES. CARBON 2.2K 5% 1/6W
R005	RD14BB2C101J	RES. CARBON 100 5% 1/6W
R006	RD14BB2C103J	RES. CARBON 10K 5% 1/6W
R007	RD14BB2C103J	RES. CARBON 10K 5% 1/6W
R008	NO USE	
R009	RD14BB2C103J	RES. CARBON 10K 5% 1/6W
R010	RD14BB2C242J	RES. CARBON 2.4K 5% 1/6W
R011	RD14BB2C243J	RES. CARBON 24K 5% 1/6W
R012	RD14BB2C104J	RES. CARBON 100K 5% 1/6W
R013	RD14BB2C104J	RES. CARBON 100K 5% 1/6W
R014	RD14BB2C104J	RES. CARBON 100K 5% 1/6W
R015	RD14BB2C104J	RES. CARBON 100K 5% 1/6W
R016	RD14BB2C104J	RES. CARBON 100K 5% 1/6W
R017	RD14BB2C104J	RES. CARBON 100K 5% 1/6W
R018	RD14BB2C103J	RES. CARBON 10K 5% 1/6W
R019	RD14BB2C103J	RES. CARBON 10K 5% 1/6W
R020	RN14BK2C5600F	RES. METAL FILM 560 1% 1/6W
R021	RD14BB2C103J	RES. CARBON 10K 5% 1/6W
R022	RN14BK2C1002F	RES. METAL FILM 10K 1% 1/6W
R023	RD14BB2C474J	RES. CARBON 470K 5% 1/6W
R024	RD14BB2C472J	RES. CARBON 4.7K 5% 1/6W
R025	RN14BK2C9100F	RES. METAL FILM 910 1% 1/6W
R026	RN14BK2C3302F	RES. METAL FILM 33K 1% 1/6W
R027	RN14BK2C5101F	RES. METAL FILM 5.1K 1% 1/6W
R028	RN14BK2C5101F	RES. METAL FILM 5.1K 1% 1/6W
R029	RD14BB2C513J	RES. CARBON 51K 5% 1/6W
R030	RD14BB2C513J	RES. CARBON 51K 5% 1/6W
R031	RD14BB2C513J	RES. CARBON 51K 5% 1/6W
R032	RD14BB2C513J	RES. CARBON 51K 5% 1/6W
R033	RD14BB2C513J	RES. CARBON 51K 5% 1/6W
R034	RD14BB2C513J	RES. CARBON 51K 5% 1/6W
R035	RD14BB2C473J	RES. CARBON 47K 5% 1/6W
R036	RD14BB2C473J	RES. CARBON 47K 5% 1/6W
R037	RN14BK2C2400F	RES. METAL FILM 240 1% 1/6W
R038	RN14BK2C1801F	RES. METAL FILM 1.8K 1% 1/6W
R039	RN14BK2C4701F	RES. METAL FILM 4.7K 1% 1/6W
R040	RN14BK2C1801F	RES. METAL FILM 1.8K 1% 1/6W
R041	RN14BK2C4701F	RES. METAL FILM 4.7K 1% 1/6W
R042	RN14BK2C2400F	RES. METAL FILM 240 1% 1/6W
R043	RD14BB2C473J	RES. CARBON 47K 5% 1/6W
R044	RD14BB2C101J	RES. CARBON 100 5% 1/6W
R045	RD14BB2C102J	RES. CARBON 1K 5% 1/6W
R046	RD14BB2C473J	RES. CARBON 47K 5% 1/6W
R047	RD14BB2C473J	RES. CARBON 47K 5% 1/6W
R048	RD14BB2C102J	RES. CARBON 1K 5% 1/6W
R049	RD14BB2C473J	RES. CARBON 47K 5% 1/6W
R050	RD14BB2C473J	RES. CARBON 47K 5% 1/6W
R051	RD14BB2C134J	RES. CARBON 130K 5% 1/6W
R052	RD14BB2C152J	RES. CARBON 1.5K 5% 1/6W
R053	RD14BB2C152J	RES. CARBON 1.5K 5% 1/6W
R054	RD14BB2C103J	RES. CARBON 10K 5% 1/6W
R055	RD14BB2C103J	RES. CARBON 10K 5% 1/6W
R056	E31-2170-05	JUMPING WIRE
R057	NO USE	
R058	R90-0662-05	RES. NETWORK 4X100K
R059	R90-0661-05	RES. NETWORK 470 5% 1/6W
R060	RD14BB2C471J	RES. CARBON 100 5% 1/6W
R061	RD14BB2C101J	RES. CARBON 100 5% 1/6W
R062	R90-0663-05	RES. NETWORK 8X1M
R063	NO USE	
R064	RD14BB2C103J	RES. CARBON 10K 5% 1/6W
R065	RD14BB2C101J	RES. CARBON 100 5% 1/6W
R066	RD14BB2C101J	RES. CARBON 100 5% 1/6W
R067	RD14BB2C101J	RES. CARBON 100 5% 1/6W
R068	NO USE	

PARTS LIST

REF. NO	PARTS NO	NAME & DESCRIPTION
R069	RD148B2C103J	RES. CARBON 10K 5% 1/6W
R070	RD148B2C162J	RES. CARBON 1.6K 5% 1/6W
R071	RD148B2C101J	RES. CARBON 100 5% 1/6W
R072	RD148B2C101J	RES. CARBON 100 5% 1/6W
R073	RD148B2C101J	RES. CARBON 100 5% 1/6W
R074	RD148B2C101J	RES. CARBON 100 5% 1/6W
R075	RD148B2C101J	RES. CARBON 100 5% 1/6W
R076	RD148B2C222J	RES. CARBON 2.2K 5% 1/6W
R077	RD148B2C222J	RES. CARBON 2.2K 5% 1/6W
R078	RD148B2C222J	RES. CARBON 2.2K 5% 1/6W
R079	RD148B2C222J	RES. CARBON 2.2K 5% 1/6W
R080	RN148K2C2001F	RES. METAL FILM 2K 1% 1/6W
R081	RN148K2C2001F	RES. METAL FILM 2K 1% 1/6W
R082	RD148B2C622J	RES. CARBON .6.2K 5% 1/6W
R083	RN148K2C5600F	RES. METAL FILM 560 1% 1/6W
R128	E31-2170-05	JUMPING WIRE
U001	LC3517BML-15	IC.2048X8 STATIC RAM
U001	MB8416-20LPF	IC.2048X8 STATIC RAM
U002	MBM27C128*S	IC.16384X8 EPROM
U003	MSM6242BGS-VK	IC.REAL TIME CLOCK
U004	PST518B	IC.RESET
U005	LH0080A	IC.CPU
U006	DTM-5010	IC. GATE ARRAY
U007	HD74LS138FP	IC.3-TO-8 DEMULTIPLEXER
U008	HD74HC238FP	IC.3-TO-8 LINE DECODER
U009	HD74HC238FP	IC.3-TO-8 LINE DECODER
U010	HD74HC107FP	IC.DUAL J-K FLIP-FLOP
U011	HD74LS04FP	IC.HEX INVERTERS
U012	HD74LS244FP	IC.OCTAL 3-STATE BUS BUFFER
U013	HD74LS244FP	IC.OCTAL 3-STATE BUS BUFFER
U014	HD74LS04FP	IC.HEX INVERTERS
U015	HD74LS30FP	IC.8-INPUT NAND
U016	HD74LS374FP	IC.OCTAL 3-STATE D-FF
U017	HD74LS244FP	IC.OCTAL 3-STATE BUS BUFFER
U018	HD74LS244FP	IC.OCTAL 3-STATE BUS BUFFER
U019	HD14066BFP	IC.QUAD BILATERAL SWITCH
U020	HD74LS107AFP	IC.QUAD JK-FF WITH CLEAR
U021	HD74LS107AFP	IC.QUAD JK-FF WITH CLEAR
U022	HD74LS107AFP	IC.QUAD JK-FF WITH CLEAR
U023	HD74LS107AFP	IC.QUAD JK-FF WITH CLEAR
U024	HD74LS30FP	IC.8-INPUT NAND
U025	HD74LS11FP	IC.TRIPLE 3-INPUT AND
U026	NJM555M	IC.TIMER
U027	HD74LS157FP	IC.2 TO 1 DATA SELECTORS
U028	HD74LS157FP	IC.2 TO 1 DATA SELECTORS
U029	HD74HC08FP	IC.QUAD 2-INPUT AND GATE
U030	HD74HC7266FP	IC.QUAD 2-INPUT NOR GATE
U031	HD74HC08FP	IC.QUAD 2-INPUT AND GATE
U032	MBM27C64*U	IC.8192X8 EPROM
U033	CTMS020	IC.GATE ARRAY (R/O CONTROLLER)
U034	HD14051BFP	IC.8-CH ANALOG MPX/DE-MPX
U035	NJM311M	IC.VOLTAGE COMPARATOR
U036	HD74HC174FP	IC.HEX D-TYPE FLIP-FLOP
U037	AM6012DC	IC.12-BIT D/A CONVERTER
U038	HD74HC564FP	IC.OCTAL D-TYPE FLIP-FLOP
U039	HD74HC244FP	IC.OCTAL BUS BUFFER
U040	HD14052BFP	IC.DUAL 4-CH ANALOG MPX/DE-MPX
U041	HD14051BFP	IC.8-CH ANALOG MPX/DE-MPX
U042	DAC0808LCN	IC.8-BIT D/A CONVERTER
U043	HD14052BFP	IC.DUAL 4-CH ANALOG MPX/DE-MPX
U044	NJM072M	IC.DUAL J-FET INPUT OP AMP
U045	NJM072M	IC.DUAL J-FET INPUT OP AMP
U046	NJM072M	IC.DUAL J-FET INPUT OP AMP
U047	NJM072M	IC.DUAL J-FET INPUT OP AMP
X001	L78-0107-05	CERAMIC RESONATOR (10MHZ)
X002	L77-1229-05	CRYSTAL (SUB L77-1025-05)

CONNECTION UNIT

X77-1500-00

REF. NO	PARTS NO	NAME & DESCRIPTION
P003	E40-7034-05	PIN CONNECTOR 40P
P010	E40-7036-05	PIN CONNECTOR 20P
P011	NO USE	
P012	E31-5551-05	LEAD WIRE WITH CONNECTOR 10P
P013	E31-5550-05	LEAD WIRE WITH CONNECTOR 6P
P017	E31-5552-05	LEAD WIRE WITH CONNECTOR 11P
P018	E40-7034-05	PIN CONNECTOR 40P
P019	E31-5553-05	LEAD WIRE WITH CONNECTOR 12P

FINAL AMP UNIT

X80-1100-01

REF. NO	PARTS NO	NAME & DESCRIPTION
	J25-5196-03	PCB (UNMOUNTED)
	N09-0718-05	SCREW, SEMS PAN HD M3X6
	N89-3008-41	SCREW, BINDING TAP TITE M3X8
71	F01-0866-04	HEAT SINK
72	F02-0502-04	HEAT SINK
C001	CK45FB1H102K	CAP. CERAMIC 1000P 10% 50V
C002	C91-1275-05	CAP. ELECTRO 0.033F 5.5V
C003	C91-1275-05	CAP. ELECTRO 0.033F 5.5V
C004	C092FM1H472K	CAP. MYLAR 4700P 10% 50V
C005	CE04HW1H010M	CAP. ELECTRO 1 20% 50V
C006	CC45FCH1H330J	CAP. CERAMIC 33P 5% 50V
C007	CC45FCH1H070D	CAP. CERAMIC 7P 0.5P 50V
C008	NO USE	
C009	CC45FCH1H330J	CAP. CERAMIC 33P 5% 50V
C010	CC45FCH1H390J	CAP. CERAMIC 39P 5% 50V
C011	C092FM1H104K	CAP. MYLAR 0.1 10% 50V
C012	C092FM1H104K	CAP. MYLAR 0.1 10% 50V
C013	CK45FF1H103Z	CAP. CERAMIC 0.01 50V
C014	CC45FSL1H561J	CAP. CERAMIC 560P 5% 50V
C015	CK45FF1H103Z	CAP. CERAMIC 0.01 50V
C020	CC45CH1H120J	CAP. CERAMIC 12P 5% 50V
C103	CC45FCH1H020C	CAP. CERAMIC 2P 0.25P 50V
C104	CK45FF1H103Z	CAP. CERAMIC 0.01 50V
C105	CK45FB2H472K	CAP. CERAMIC 4700P 10% 500V
C108	CC45FCH1H070D	CAP. CERAMIC 7P 0.5P 50V
C109	CC45FCH2H020C	CAP. CERAMIC 2P 0.25P 500V
C110	CC45FCH2HOR5C	CAP. CERAMIC 0.5P 0.25P 500V
C111	CF93AN2E103K	CAP. METAL FILM 0.01 10% 250V
C112	CF93AN2E103K	CAP. METAL FILM 0.01 10% 250V
C113	CF93AN2E104K	CAP. METAL FILM 0.1 10% 250V
C114	CF93AN2E104K	CAP. METAL FILM 0.1 10% 250V
C115	CC45FCH1H040C	CAP. CERAMIC 4P 0.25P 50V
C116	CE04HW1E220M	CAP. ELECTRO 22 20% 25V
C301	CE04EW1C331M	CAP. ELECTRO 330 20% 16V
C302	CE04EW1C331M	CAP. ELECTRO 330 20% 16V
C303	CE04EW1E101M	CAP. ELECTRO 100 20% 25V
C304	CE04EW2A220M	CAP. ELECTRO 22 20% 100V
C305	CE04W2E4R7M	CAP. ELECTRO 4.7 20% 250V
C306	CK45FF1H103Z	CAP. CERAMIC 0.01 50V
C307	CK45FF1H103Z	CAP. CERAMIC 0.01 50V
C308	CK45FF1H103Z	CAP. CERAMIC 0.01 50V
C309	C092FM1H104K	CAP. MYLAR 0.1 10% 50V
C310	CK45FF1H103Z	CAP. CERAMIC 0.01 50V
C311	CK45FF1H103Z	CAP. CERAMIC 0.01 50V
C312	CK45FB2H472K	CAP. CERAMIC 4700P 10% 500V
C313	CK45FB2H472K	CAP. CERAMIC 4700P 10% 500V
C314	CK45FB2H472K	CAP. CERAMIC 4700P 10% 500V
C501	C092M1H102K	CAP. MYLAR 1000P 10% 50V
D001	1SS132	DIODE
D002	1SS132	DIODE
D101	TLR112	LED, RED
D102	MA700	DIODE
D105	MA700	DIODE
D106	TLR112	LED, RED
D107	1SS132	DIODE
D108	1SS132	DIODE
D201	1SS132	DIODE
D202	1SS132	DIODE
L001	L33-0806-05	CHOKE COIL (0.52UH)
L002	L33-0806-05	CHOKE COIL (0.52UH)
L003	L33-0806-05	CHOKE COIL (0.52UH)
L004	L33-0806-05	CHOKE COIL (0.52UH)
L005	L40-2202-70	FERRI INDUCTOR 22UH
P011	E40-0373-05	PIN CONNECTOR 3P
P012	E40-1073-05	PIN CONNECTOR 10P
P013	E40-0673-05	PIN CONNECTOR 6P
P014	E40-0373-05	PIN CONNECTOR 3P
P015	E40-0373-05	PIN CONNECTOR 3P
Q001	2SC3779(D)	TR. SI, NPN
Q002	2SC3779(D)	TR. SI, NPN
Q003	2SC3779(D)	TR. SI, NPN
Q004	2SC3779(D)	TR. SI, NPN
Q005	2SA1161	TR. SI, PNP
Q006	2SA1161	TR. SI, PNP

PARTS LIST

REF. NO	PARTS NO	NAME & DESCRIPTION
Q007	2SC3779(D)	TR. SI. NPN
Q008	2SC3779(D)	TR. SI. NPN
Q009	2SC3779(D)	TR. SI. NPN
Q010	2SC3779(D)	TR. SI. NPN
Q011	2SC3779(D)	TR. SI. NPN
Q012	2SC3779(D)	TR. SI. NPN
Q013	2SC1164(O)*S	TR. SI. NPN
Q014	2SC1164(O)*S	TR. SI. NPN
Q101	2SA1005(K)	TR. SI. PNP
Q102	2SA1005(K)	TR. SI. PNP
Q103	2SC3315(C)	TR. SI. NPN
Q104	2SC3315(C)	TR. SI. NPN
Q105	2SA1005(K)	TR. SI. PNP
Q106	2SA1005(K)	TR. SI. PNP
Q107	2SA1005(K)	TR. SI. PNP
Q108	2SA1005(K)	TR. SI. PNP
Q109	2SC3354(T,S)	TR. SI. NPN
Q110	2SC3354(T,S)	TR. SI. NPN
Q111	2SA1206	TR. SI. PNP
Q112	2SC3354(T,S)	TR. SI. NPN
Q113	2SC3354(T,S)	TR. SI. NPN
Q114	2SC3600(E,F)	TR. SI. NPN
Q115	2SC3600(E,F)	TR. SI. NPN
Q116	2SA1406(E,F)	TR. SI. PNP
Q117	2SA1406(E,F)	TR. SI. PNP
Q201	2SC3315(C)	TR. SI. NPN
Q202	2SC3315(C)	TR. SI. NPN
Q203	2SC3354(T,S)	TR. SI. NPN
Q204	2SC3354(T,S)	TR. SI. NPN
Q205	2SC2785(F)	TR. SI. NPN
Q206	2SC3315(C)	TR. SI. NPN
Q207	2SC3315(C)	TR. SI. NPN
Q208	2SC3354(T,S)	TR. SI. NPN
Q209	2SC3354(T,S)	TR. SI. NPN
Q210	2SC2785(F)	TR. SI. NPN
R001	RN14BK2C1000F	RES. METAL FILM 100 1% 1/6W
R002	RN14BK2C1000F	RES. METAL FILM 100 1% 1/6W
R003	RD14BB2C470J	RES. CARBON 47 5% 1/6W
R004	RD14BB2C470J	RES. CARBON 47 5% 1/6W
R005	RD14BB2C101J	RES. CARBON 100 5% 1/6W
R006	RD14BB2C432J	RES. CARBON 4.3K 5% 1/6W
R007	RD14BB2C432J	RES. CARBON 4.3K 5% 1/6W
R008	RD14BB2C101J	RES. CARBON 100 5% 1/6W
R009	RD14BB2C470J	RES. CARBON 47 5% 1/6W
R010	RD14BB2C470J	RES. CARBON 47 5% 1/6W
R011	RD14BB2C152J	RES. CARBON 1.5K 5% 1/6W
R012	RD14BB2C152J	RES. CARBON 1.5K 5% 1/6W
R013	RD14BB2C303J	RES. CARBON 30K 5% 1/6W
R014	RD14BB2C753J	RES. CARBON 75K 5% 1/6W
R015	RN14BK2C2700F	RES. METAL FILM 270 1% 1/6W
R016	RN14BK2C2700F	RES. METAL FILM 270 1% 1/6W
R017	RN14BK2C2700F	RES. METAL FILM 270 1% 1/6W
R018	RD14BB2C104J	RES. CARBON 100K 5% 1/6W
R019	RD14BB2C104J	RES. CARBON 100K 5% 1/6W
R020	RN14BK2C3000F	RES. METAL FILM 300 1% 1/6W
R021	RN14BK2C3000F	RES. METAL FILM 300 1% 1/6W
R022	RD14BB2C681J	RES. CARBON 680 5% 1/6W
R023	RD14BB2C681J	RES. CARBON 680 5% 1/6W
R024	RD14BB2C821J	RES. CARBON 820 5% 1/6W
R025	RN14BK2C2201F	RES. METAL FILM 2.2K 1% 1/6W
R026	RN14BK2C2201F	RES. METAL FILM 2.2K 1% 1/6W
R027	RD14BB2C152J	RES. CARBON 1.5K 5% 1/6W
R028	RD14BB2C152J	RES. CARBON 1.5K 5% 1/6W
R029	RD14BB2C101J	RES. CARBON 100 5% 1/6W
R030	RD14BB2C101J	RES. CARBON 100 5% 1/6W
R031	RD14BB2C470J	RES. CARBON 47 5% 1/6W
R032	RD14BB2C470J	RES. CARBON 47 5% 1/6W
R033	RD14BB2C470J	RES. CARBON 47 5% 1/6W
R034	RD14BB2C470J	RES. CARBON 47 5% 1/6W
R035	RN14BK2E82R0F	RES. METAL FILM 82.0 1% 1/4W
R036	RN14BK2E82R0F	RES. METAL FILM 82.0 1% 1/4W
R037	RN14BK2C1500F	RES. METAL FILM 150 1% 1/6W
R038	R92-1191-05	
R039	RD14BB2C513J	RES. CARBON 51K 5% 1/6W
R040	RD14BB2C240J	RES. CARBON 24 5% 1/6W
R041	RD14BB2C470J	RES. CARBON 47 5% 1/6W
R042	RD14BB2C680J	RES. CARBON 68 5% 1/6W
R043	RD14BB2C222J	RES. CARBON 2.2K 5% 1/6W
R044	RD14BB2C223J	RES. CARBON 22K 5% 1/6W
R045	RD14BB2E220J	RES. CARBON 22 5% 1/4W
R046	RD14BB2E220J	RES. CARBON 22 5% 1/4W
R047	RD14BB2C220J	RES. CARBON 22 5% 1/6W
R048	RD14BB2C220J	RES. CARBON 22 5% 1/6W
R049	NO USE	
R050	R92-1420-05	RES. METAL FILM 510 5% 7W
R051	RD14BB2C220J	RES. CARBON 22 5% 1/6W
R052	R92-1420-05	RES. METAL FILM 510 5% 7W
R053	RD14BB2C220J	RES. CARBON 22 5% 1/6W

REF. NO	PARTS NO	NAME & DESCRIPTION
R054	NO USE	
R055	RD14BB2C361J	RES. CARBON 360 5% 1/6W
R056	RD14BB2C361J	RES. CARBON 360 5% 1/6W
R059	RD14BB2C223J	RES. CARBON 22K 5% 1/6W
R070	RD14BB2C100J	RES. CARBON 10 5% 1/6W
R101	RD14BB2C220J	RES. CARBON 22 5% 1/6W
R102	RD14BB2C220J	RES. CARBON 22 5% 1/6W
R103	RN14BK2C4300F	RES. METAL FILM 430 1% 1/6W
R104	RN14BK2C4300F	RES. METAL FILM 430 1% 1/6W
R105	RD14BB2C220J	RES. CARBON 22 5% 1/6W
R106	RD14BB2C220J	RES. CARBON 22 5% 1/6W
R107	RN14BK2C3001F	RES. METAL FILM 3K 1% 1/6W
R108	RN14BK2C5101F	RES. METAL FILM 5.1K 1% 1/6W
R109	RN14BK2C1201F	RES. METAL FILM 1.2K 1% 1/6W
R110	RN14BK2C3001F	RES. METAL FILM 3K 1% 1/6W
R111	RN14BK2C3001F	RES. METAL FILM 3K 1% 1/6W
R112	RD14BB2C151J	RES. CARBON 150 5% 1/6W
R113	RD14BB2C431J	RES. CARBON 430 5% 1/6W
R114	RD14BB2C431J	RES. CARBON 430 5% 1/6W
R115	RD14BB2C104J	RES. CARBON 100K 5% 1/6W
R116	RD14BB2C104J	RES. CARBON 100K 5% 1/6W
R117	RN14BK2C6800F	RES. METAL FILM 680 1% 1/6W
R118	RN14BK2C6800F	RES. METAL FILM 680 1% 1/6W
R119	RN14BK2C4701F	RES. METAL FILM 4.7K 1% 1/6W
R120	RN14BK2C3901F	RES. METAL FILM 3.9K 1% 1/6W
R121	RD14BB2C220J	RES. CARBON 22 5% 1/6W
R122	RD14BB2C220J	RES. CARBON 22 5% 1/6W
R123	RN14BK2C1501F	RES. METAL FILM 1.5K 1% 1/6W
R124	RN14BK2C1501F	RES. METAL FILM 1.5K 1% 1/6W
R125	RN14BK2C1501F	RES. METAL FILM 1.5K 1% 1/6W
R126	RD14BB2C392J	RES. CARBON 3.9K 5% 1/6W
R127	RD14BB2C220J	RES. CARBON 22 5% 1/6W
R128	RD14BB2C220J	RES. CARBON 22 5% 1/6W
R129	RD14BB2C392J	RES. CARBON 3.9K 5% 1/6W
R130	RD14BB2C101J	RES. CARBON 100 5% 1/6W
R131	RD14BB2C101J	RES. CARBON 100 5% 1/6W
R132	RN14BK2C1301F	RES. METAL FILM 1.3K 1% 1/6W
R133	RN14BK2C1301F	RES. METAL FILM 1.3K 1% 1/6W
R134	RD14BB2C103J	RES. CARBON 10K 5% 1/6W
R135	NO USE	
R136	RD14BB2C514J	RES. CARBON 510K 5% 1/6W
R137	RD14BB2C242J	RES. CARBON 2.4K 5% 1/6W
R138	RD14BB2C242J	RES. CARBON 2.4K 5% 1/6W
R139	RD14BB2C222J	RES. CARBON 2.2K 5% 1/6W
R140	RD14BB2C222J	RES. CARBON 2.2K 5% 1/6W
R141	RD14BB2C152J	RES. CARBON 1.5K 5% 1/6W
R142	RD14BB2C101J	RES. CARBON 100 5% 1/6W
R143	RD14BB2C101J	RES. CARBON 100 5% 1/6W
R144	RN14BK2E2002F	RES. METAL FILM 20K 1% 1/4W
R145	RN14BK2E2002F	RES. METAL FILM 20K 1% 1/4W
R146	R92-1434-05	RES. SPECIAL POWER 47K 5% 1/2W
R147	RN14BK2C7500F	RES. METAL FILM 750 1% 1/6W
R148	RN14BK2C3601F	RES. METAL FILM 3.6K 1% 1/6W
R149	RN14BK2C4702F	RES. METAL FILM 47K 1% 1/6W
R150	RN14BK2C4702F	RES. METAL FILM 47K 1% 1/6W
R151	RN14BK2C3601F	RES. METAL FILM 3.6K 1% 1/6W
R152	RN14BK2C7500F	RES. METAL FILM 750 1% 1/6W
R153	RN14BK2E2002F	RES. METAL FILM 20K 1% 1/4W
R154	RN14BK2E2002F	RES. METAL FILM 20K 1% 1/4W
R155	R92-1434-05	RES. SPECIAL POWER 47K 5% 1/2W
R156	RD14BB2C470J	RES. CARBON 47 5% 1/6W
R157	RD14BB2C821J	RES. CARBON 820 5% 1/6W
R158	RD14BB2C101J	RES. CARBON 100 5% 1/6W
R159	RD14BB2C470J	RES. CARBON 47 5% 1/6W
R160	RD14BB2C223J	RES. CARBON 22K 5% 1/6W
R161	RD14BB2C473J	RES. CARBON 47K 5% 1/6W
R162	RD14BB2C473J	RES. CARBON 47K 5% 1/6W
R163	NO USE	
R164	RD14BB2C203J	RES. CARBON 20K 5% 1/6W
R201	RD14BB2C162J	RES. CARBON 1.6K 5% 1/6W
R202	RD14BB2C102J	RES. CARBON 1K 5% 1/6W
R203	RN14BK2C1200F	RES. METAL FILM 120 1% 1/6W
R204	RN14BK2C1200F	RES. METAL FILM 120 1% 1/6W
R205	RD14BB2C621J	RES. CARBON 620 5% 1/6W
R206	RD14BB2C623J	RES. CARBON 62K 5% 1/6W
R207	RD14BB2C912J	RES. CARBON 9.1K 5% 1/6W
R208	RD14BB2C301J	RES. CARBON 300 5% 1/6W
R209	RD14BB2C302J	RES. CARBON 3K 5% 1/6W
R210	RD14BB2C332J	RES. CARBON 3.3K 5% 1/6W
R211	RD14BB2C562J	RES. CARBON 5.6K 5% 1/6W
R212	RN14BK2C5001F	RES. METAL FILM 5K 1% 1/6W
R213	RD14BB2C332J	RES. CARBON 3.3K 5% 1/6W
R214	RN14BK2C1800F	RES. METAL FILM 180 1% 1/6W
R215	RD14BB2C301J	RES. CARBON 300 5% 1/6W
R216	RD14BB2C821J	RES. CARBON 820 5% 1/6W
R217	RN14BK2C3300F	RES. METAL FILM 330 1% 1/6W
R218	RN14BK2C3300F	RES. METAL FILM 330 1% 1/6W

PARTS LIST

REF.NO	PARTS NO	NAME & DESCRIPTION			
R219	RD14BB2C221J	RES. CARBON	220	5%	1/6W
R220	RD14BB2C103J	RES. CARBON	10K	5%	1/6W
R221	RD14BB2C912J	RES. CARBON	9.1K	5%	1/6W
R222	RD14BB2C301J	RES. CARBON	300	5%	1/6W
R223	RD14BB2C302J	RES. CARBON	3K	5%	1/6W
R224	RD14BB2C332J	RES. CARBON	3.3K	5%	1/6W
R225	RD14BB2C562J	RES. CARBON	5.6K	5%	1/6W
R226	RN14BK2C9101F	RES. METAL FILM	9.1K	1%	1/6W
R227	RN14BK2C4701F	RES. METAL FILM	4.7K	1%	1/6W
R228	RN14BK2C5600F	RES. METAL FILM	560	1%	1/6W
R229	RD14BB2C163J	RES. CARBON	16K	5%	1/6W
TC001	C05-0471-05	CAP. TRIMMER	30P		
TC002	C05-0460-05	CAP. TRIMMER	20P		
TC101	C05-0464-05	CAP. TRIMMER	2P		
TC102	NO USE				
TC103	C05-0464-05	CAP. TRIMMER	2P		
TH002	SDT100	THERMISTOR			
VR001	R12-0569-05	RES. SEMI FIXED	100B		
VR002	NO USE				
VR003	R12-3453-05	RES. SEMI FIXED	10KB		
VR004	R12-0058-05	RES. SEMI FIXED	470 B		
VR101	R12-1538-05	RES. SEMI FIXED	1KB		
VR102	R12-0571-05	RES. SEMI FIXED	500B		
VR103	R12-3453-05	RES. SEMI FIXED	10KB		
VR201	R12-3543-05	RES. SEMI FIXED	20KB		
VR202	R12-3543-05	RES. SEMI FIXED	20KB		

REF.NO	PARTS NO	NAME & DESCRIPTION			
R008	RD14BB2C103J	RES. CARBON	10K	5%	1/6W
R009	RD14BB2C104J	RES. CARBON	100K	5%	1/6W
R010	RD14BB2C473J	RES. CARBON	47K	5%	1/6W
R011	RD14BB2C101J	RES. CARBON	100	5%	1/6W
R012	RD14BB2C333J	RES. CARBON	33K	5%	1/6W
R013	RD14BB2C433J	RES. CARBON	43K	5%	1/6W
R014	RD14BB2C473J	RES. CARBON	47K	5%	1/6W
R015	RD14BB2C162J	RES. CARBON	1.6K	5%	1/6W
R016	RD14BB2C182J	RES. CARBON	1.8K	5%	1/6W
R017	RD14BB2C271J	RES. CARBON	270	5%	1/6W
R018	RD14BB2C100J	RES. CARBON	10	5%	1/6W
R019	RD14BB2C272J	RES. CARBON	2.7K	5%	1/6W
R020	RD14BB2C473J	RES. CARBON	47K	5%	1/6W
R021	RD14BB2C101J	RES. CARBON	100	5%	1/6W
R022	RD14BB2C101J	RES. CARBON	100	5%	1/6W
R023	RD14BB2C102J	RES. CARBON	1K	5%	1/6W
R024	RD14BB2C102J	RES. CARBON	1K	5%	1/6W
R025	RD14BB2C100J	RES. CARBON	10	5%	1/6W
R026	RD14BB2C102J	RES. CARBON	1K	5%	1/6W
R101	RD14BY2H25J	RES. CARBON	2.2M	5%	1/2W
S101	S59-2505-05	SWITCH			
U001	NJM4558D	IC, DUAL OP AMP			
VR001	R05-3515-05	V.R. WITH SW<READOUT INT>	20KB		
VR002	R10-3505-05	V.R.<A/B INT,ROT+ILLUM>	20KB X2		
VR003	R10-7501-05	V.R.<FOCUS/ASTIG>	500KB/500KB		
VR004	R10-3505-05	V.R.<A/B INT,ROT+ILLUM>	20KB X2		
VR005	R12-3543-05	RES. SEMI FIXED	20KB		
VR006	R12-1538-05	RES. SEMI FIXED	1KB		

VR UNIT

X81-2330-01

REF.NO	PARTS NO	NAME & DESCRIPTION			
E01-0103-05		CRT SOCKET			
E31-5582-05		WIRE ASS'Y<NO.14>			
E31-5583-05		WIRE ASS'Y<NO.15>			
E31-5584-05		WIRE ASS'Y<NO.24>			
E31-5585-05		WIRE ASS'Y<NO.23>			
F01-0859-14		HEAT SINK			
N09-0623-04		SCREW, SEMS	M3X8		
R92-0150-05		JUMPING RES.	ZERO OHM<10MM>		
77	J21-4610-04	BRACKET			
C001	CC45CH2HORSC	CAP. CERAMIC	0.5P	0.25P	500V
C002	CC45CH2HORSC	CAP. CERAMIC	0.5P	0.25P	500V
C006	CE04EW1C101M	CAP. ELECTRO	100	20%	16V
C007	CK45F1H103Z	CAP. CERAMIC	0.01		50V
C008	CK45FB2H472K	CAP. CERAMIC	4700P	10%	500V
C009	C092M1H103J	CAP. MYLAR	0.01	5%	50V
C010	CE04EW1C470M	CAP. ELECTRO	47	20%	16V
C101	C91-0551-05	CAP. POLYESTER	0.22	10%	630V
C102	C91-0575-05	CAP. CERAMIC	1000P		4KV
C103	C91-0575-05	CAP. CERAMIC	1000P		4KV
D001	1SS132	DIODE			
D002	1SS132	DIODE			
D003	MTZ24JC	DIODE, ZENER	23.72V		
J021	E31-5571-05	LEAD WIRE WITH CONNECTOR			
L101	L33-0808-05	CHOKE COIL			
P020	E40-0328-05	PIN CONNECTOR	3 P		
P021	E40-0328-05	PIN CONNECTOR	3 P		
P025	E40-0474-05	PIN CONNECTOR	4P		
P026	E40-1074-05	PIN CONNECTOR	10P		
P027	E40-0273-05	PIN CONNECTOR	2P		
P028	E40-0274-05	PIN CONNECTOR	2P		
P029	E40-0274-05	PIN CONNECTOR	2P		
Q002	2SC1384(Q)	TR. SI, NPN			
Q003	2SA684(Q)	TR. SI, PNP			
Q004	2SA1175(F)	TR. SI, PNP			
Q005	2SC2785(F)	TR. SI, NPN			
Q006	2SD1666(S)	TR. SI, NPN			
R001	RD14BB2C101J	RES. CARBON	100	5%	1/6W
R004	RD14BB2C221J	RES. CARBON	220	5%	1/6W
R005	RD14BB2C220J	RES. CARBON	22	5%	1/6W
R006	RD14BB2C102J	RES. CARBON	1K	5%	1/6W
R007	RD14BB2C102J	RES. CARBON	1K	5%	1/6W



SCHEMATIC DIAGRAM

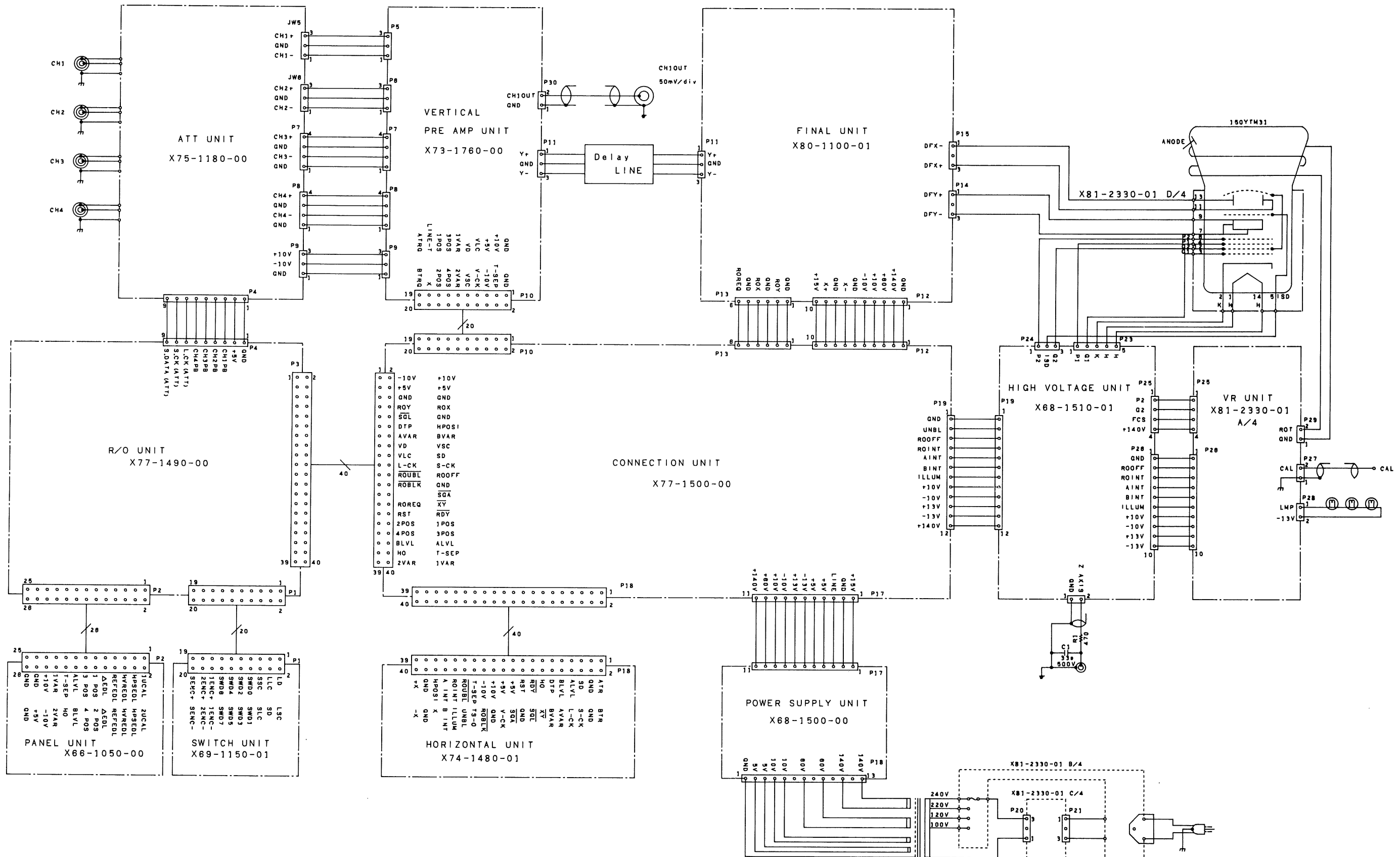

SCHEMATIC DIAGRAM

SWITCH UNIT (X69-1150-01)

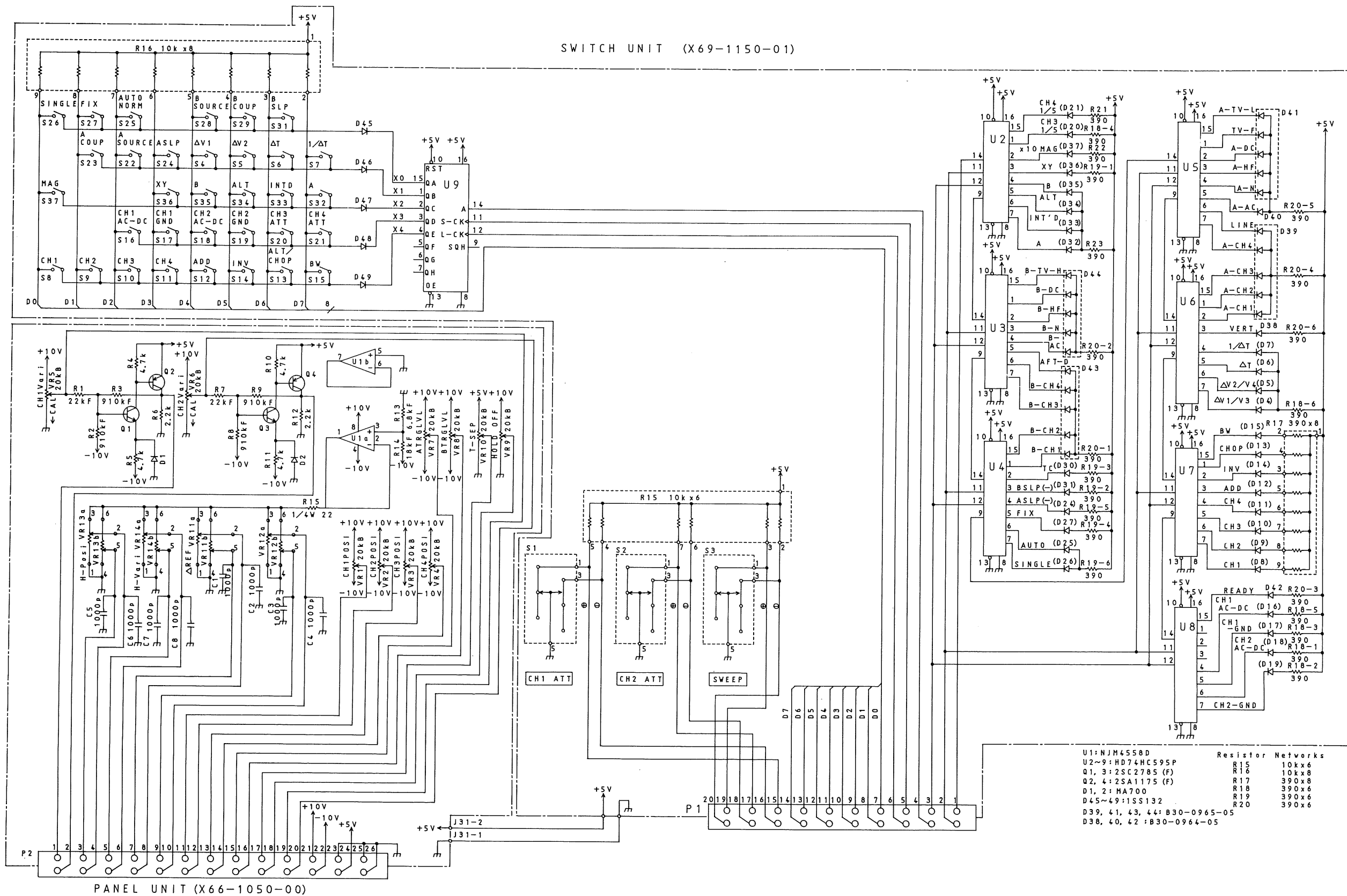

VERTICAL PREAMP UNIT (X73-1760-00)

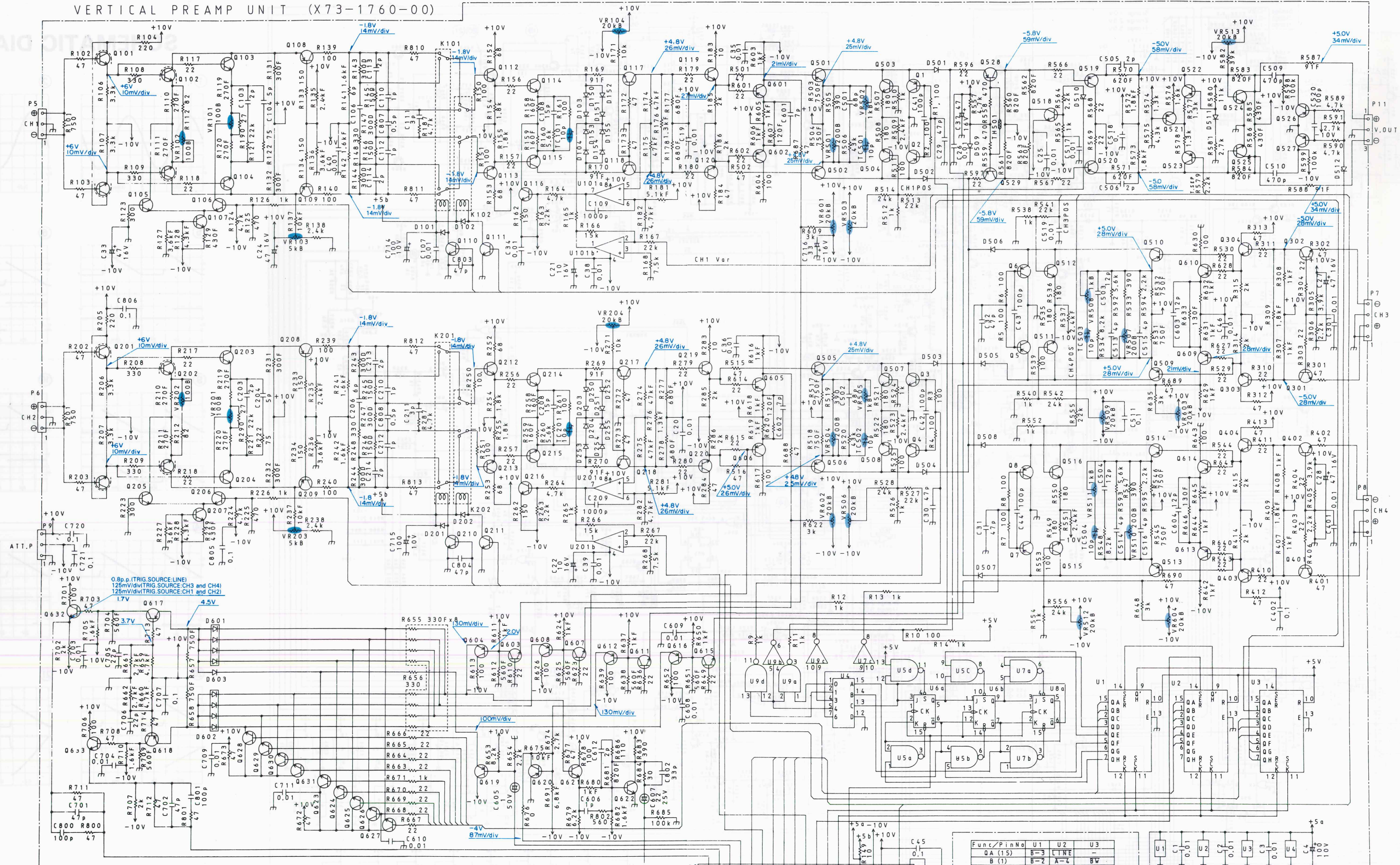

- 25A1175 (F) : 0521, 522, 523, 619, 0620
- 25A1206 : 0501, 502, 505, 506, 0509, 510, 513, 514, 0519, 520, 526, 527, 0601, 602, 604, 605, 0606, 608, 609, 610, 0612, 613, 614, 616
- 25A1005 (K) : 01~8
- 25A1161 : 0108, 109, 208, 209, 0528, 529, 617, 618
- 25C3315 (C) : 0105, 106, 107, 205, 0206, 207, 503, 504, 0507, 508, 511, 512, 0515, 516, 624, 625, 0626, 627, 628, 629, 0630, 631
- 25C2785 (F) : 0116, 216, 623
- 25C3732 (L) : 0518
- 25C3779 (D) : 0103, 104, 112~115, 0117~120, 203, 204, 0212~215, 217~220, 0301~304, 401~404, 0524, 525, 603, 607, 0611, 615, 621, 622, 0632, 633
- 25C4049 : 0110, 111, 210, 211
- 25C4072 : 0101, 102, 201, 202

Func./Pin No	U1	U2	U3
QA (15)	B-3	LINE	-
B (1)	B-2	A-2	BW
C (2)	B-1	A-3	CH2 1/4
D (3)	ADDE	A-2	CH2 1-2
E (4)	CH2E	A-1	CH2 HA6
F (5)	CH2E	B-2	CH1 1/4
G (6)	CH2E	B-1	CH1 1/2
H (7)	CH2E	CH1 HA6	

SN74ALS00AN	: U5, 7, 9	1SS132	: D101, 102, 201, 202,	MA700	: D103, 104, 150~155,
SN74ALS112AN	: U6, 8		D501~508, 509, 511,		: D203, 204, 250~255
HD74LS42P	: U4		D603	MTZ10JC	: D510
HD74HC595P	: U1, 2, 3	DAP401	: D601, 602	SOT-100	: TH501
NJM4558D	: U101, 201	MTZ5.1JB	: D512		

HORIZONTAL UNIT (X74-1480-01)

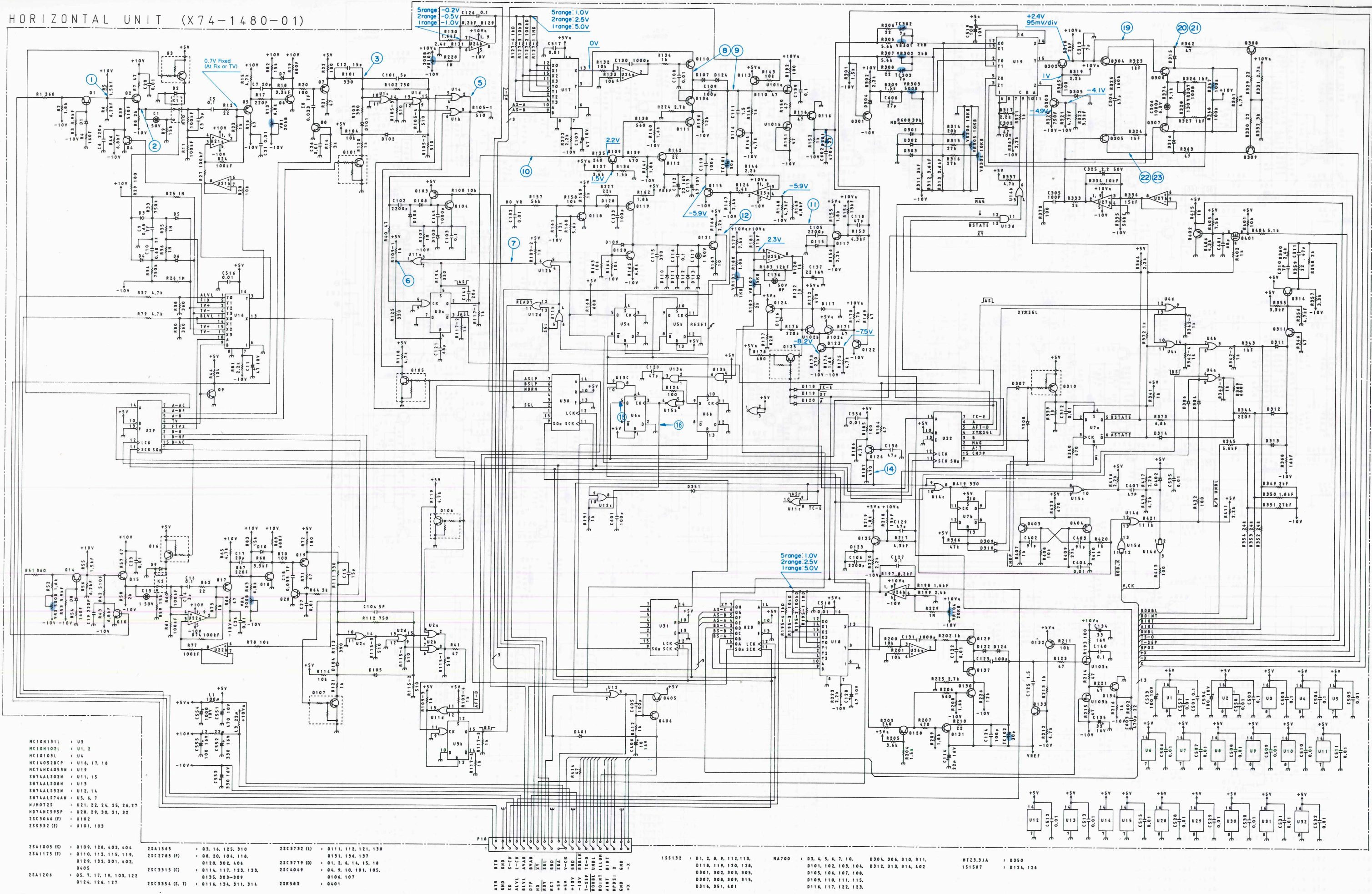

- HC10K131L U3
- HC10K102L U1, 2
- HC10103L U4
- HC14052BCP U16, 17, 18
- HC74NC4053M U19
- SN74ALS02N U11, 15
- SN74ALS00N U13
- SN74ALS32N U12, 14
- SN74ALS74AH U5, 6, 7
- SN74072 U21, 22, 24, 25, 26, 27
- NOT4NC595P U28, 29, 30, 31, 32
- 2SC3044 (F) U102
- 2SK932 (E) U101, 103

- 2SA1005 (K) U109, 120, 403, 404
- 2SA1175 (F) U110, 113, 115, 119, 129, 132, 301, 402, 405
- 2SA1204 U5, 7, 17, 19, 103, 122, 124, 126, 127
- 2SA1565 U3, 16, 125, 310
- 2SC2785 (F) U8, 20, 104, 118, 0120, 302, 406
- 2SC3315 (C) U114, 117, 123, 133, 0135, 303-309
- 2SC3954 (S, T) U116, 134, 311, 314
- 2SC9792 (L) U111, 112, 121, 130, 0131, 134, 137
- 2SC9779 (D) U1, 2, 6, 14, 15, 18, 04, 9, 10, 101, 105, 0106, 107
- 2SK503 U401

- ATF U1
- BD U2
- CD U3
- DD U4
- EE U5
- FF U6
- GG U7
- HH U8
- II U9
- JJ U10
- KK U11
- LL U12
- MM U13
- NN U14
- OO U15
- PP U16
- QQ U17
- RR U18
- SS U19
- TT U20
- UU U21
- VV U22
- WW U23
- XX U24
- YY U25
- ZZ U26

- ATF U1
- BD U2
- CD U3
- DD U4
- EE U5
- FF U6
- GG U7
- HH U8
- II U9
- JJ U10
- KK U11
- LL U12
- MM U13
- NN U14
- OO U15
- PP U16
- QQ U17
- RR U18
- SS U19
- TT U20
- UU U21
- VV U22
- WW U23
- XX U24
- YY U25
- ZZ U26

- ATF U1
- BD U2
- CD U3
- DD U4
- EE U5
- FF U6
- GG U7
- HH U8
- II U9
- JJ U10
- KK U11
- LL U12
- MM U13
- NN U14
- OO U15
- PP U16
- QQ U17
- RR U18
- SS U19
- TT U20
- UU U21
- VV U22
- WW U23
- XX U24
- YY U25
- ZZ U26

- ATF U1
- BD U2
- CD U3
- DD U4
- EE U5
- FF U6
- GG U7
- HH U8
- II U9
- JJ U10
- KK U11
- LL U12
- MM U13
- NN U14
- OO U15
- PP U16
- QQ U17
- RR U18
- SS U19
- TT U20
- UU U21
- VV U22
- WW U23
- XX U24
- YY U25
- ZZ U26

- ATF U1
- BD U2
- CD U3
- DD U4
- EE U5
- FF U6
- GG U7
- HH U8
- II U9
- JJ U10
- KK U11
- LL U12
- MM U13
- NN U14
- OO U15
- PP U16
- QQ U17
- RR U18
- SS U19
- TT U20
- UU U21
- VV U22
- WW U23
- XX U24
- YY U25
- ZZ U26

- ATF U1
- BD U2
- CD U3
- DD U4
- EE U5
- FF U6
- GG U7
- HH U8
- II U9
- JJ U10
- KK U11
- LL U12
- MM U13
- NN U14
- OO U15
- PP U16
- QQ U17
- RR U18
- SS U19
- TT U20
- UU U21
- VV U22
- WW U23
- XX U24
- YY U25
- ZZ U26

- ATF U1
- BD U2
- CD U3
- DD U4
- EE U5
- FF U6
- GG U7
- HH U8
- II U9
- JJ U10
- KK U11
- LL U12
- MM U13
- NN U14
- OO U15
- PP U16
- QQ U17
- RR U18
- SS U19
- TT U20
- UU U21
- VV U22
- WW U23
- XX U24
- YY U25
- ZZ U26

- ATF U1
- BD U2
- CD U3
- DD U4
- EE U5
- FF U6
- GG U7
- HH U8
- II U9
- JJ U10
- KK U11
- LL U12
- MM U13
- NN U14
- OO U15
- PP U16
- QQ U17
- RR U18
- SS U19
- TT U20
- UU U21
- VV U22
- WW U23
- XX U24
- YY U25
- ZZ U26

- ATF U1
- BD U2
- CD U3
- DD U4
- EE U5
- FF U6
- GG U7
- HH U8
- II U9
- JJ U10
- KK U11
- LL U12
- MM U13
- NN U14
- OO U15
- PP U16
- QQ U17
- RR U18
- SS U19
- TT U20
- UU U21
- VV U22
- WW U23
- XX U24
- YY U25
- ZZ U26



SCHEMATIC DIAGRAM

①

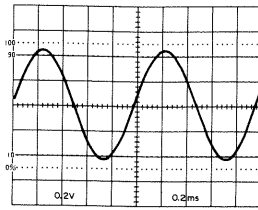

②

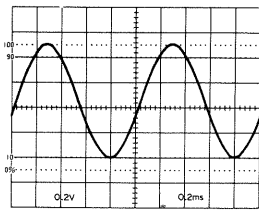

③

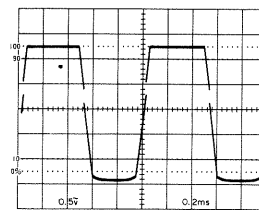

④

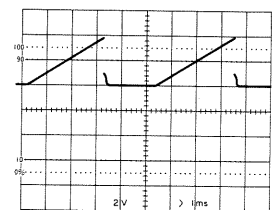

⑤

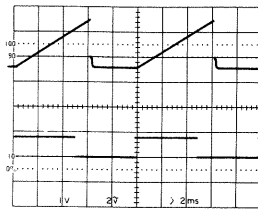

⑥

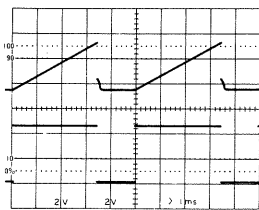

⑦

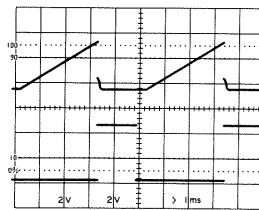

⑧

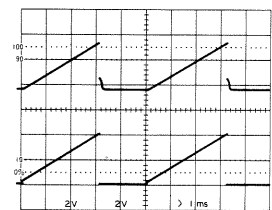

⑨

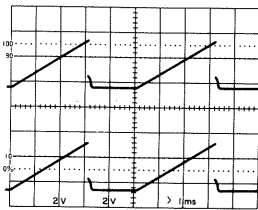

⑩

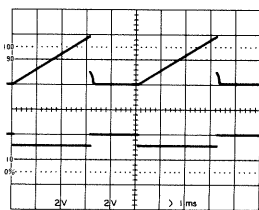

⑪

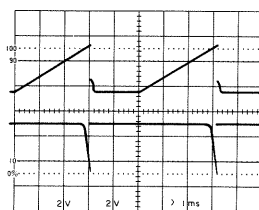

⑫

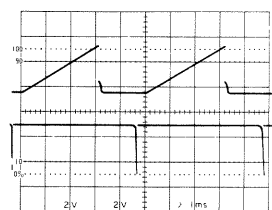

⑬

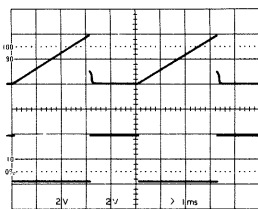

⑮

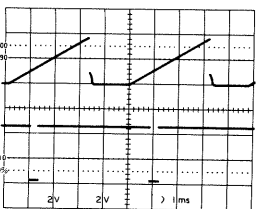

⑯

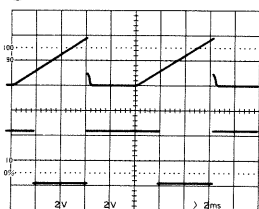

⑰

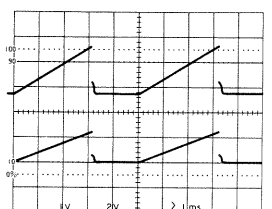

⑳

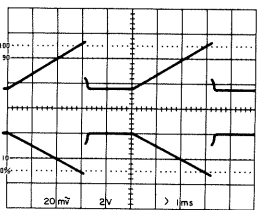

㉑

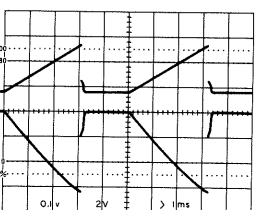

㉒

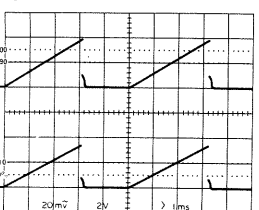

㉓

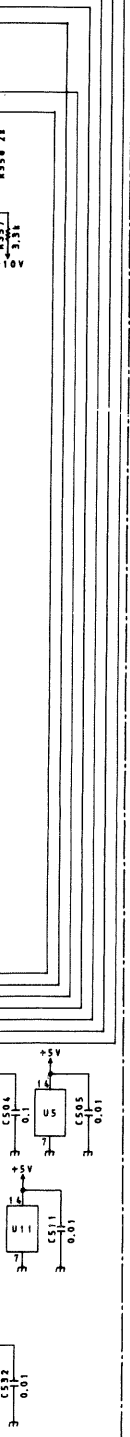
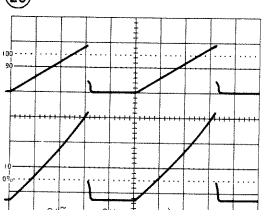

SCHEMATIC DIAGRAM

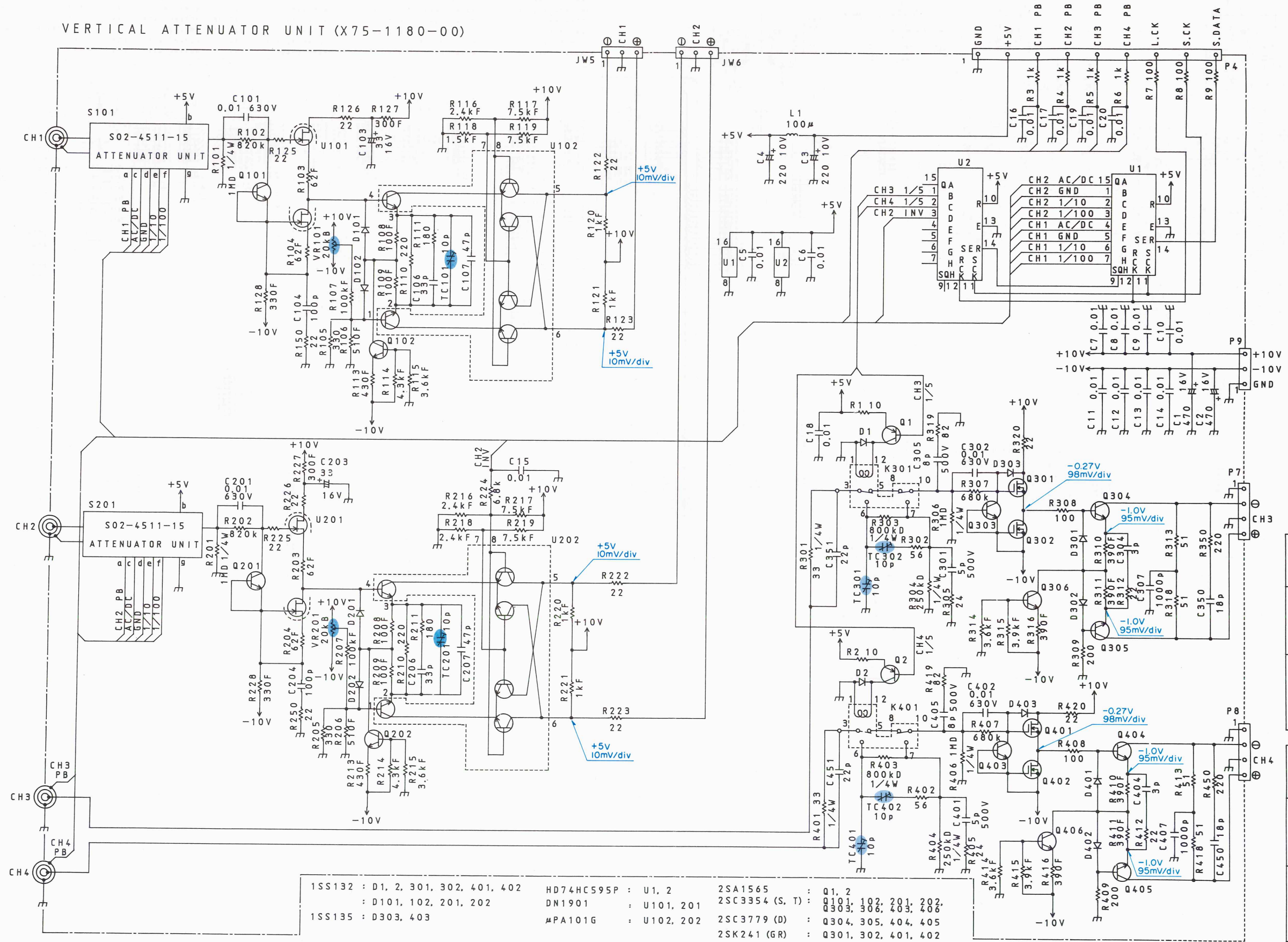

- | | | |
|------------------------------------|---------------------|--------------------------------------|
| 1SS132 : D1, 2, 301, 302, 401, 402 | HD74HCS95P : U1, 2 | 2SA1565 : Q1, 2 |
| : D101, 102, 201, 202 | DN1901 : U101, 201 | 2SC3354 (S, T) : Q303, 306, 403, 406 |
| 1SS135 : D303, 403 | #PA101G : U102, 202 | 2SC3779 (D) : Q304, 305, 404, 405 |
| | | 2SK241 (GR) : Q301, 302, 401, 402 |

FUNC/PinNo	U1	U2
QA (4)	CH1 AC/DC	-
F (5)	CH1 GND	-
G (6)	CH1 1/10	-
H (7)	CH1 1/100	-

FUNC/PinNo	U1	U2
CH2 AC/DC	-	-
CH2 1/5	CH3 1/5	-
CH2 1/10	CH4 1/5	-
CH2 1/100	CH2 INV	-

SCHEMATIC DIAGRAM

M88416-20LPF : U1	HD74HC238FP : U8, 9	HD74LS107AFP : U20-23	CTMS020 : U33	HD140528FP : U40,43
M8M27C128XS : U2	HD74HC107FP : U10	HD74LS11FP : U25	HD140518FP : U34, 41	DAC0808LCN : U42
M5M62428GS-VK : U3	HD74LS04FP : U11, 14	NJM555M : U26	NJM311M : U35	NJM702M : U44-47
PST518B : U4	HD74LS214FP : U12, 13, 17, 18	HD74LS157FP : U27, 28	HD74HC174FP : U36	2SA1175(F) : Q1
LH0080A : U5	HD74LS30FP : U15, 24	HD74HC08FP : U29, 31	AM6012DC : U37	2SC1384(R,S) : Q2
DTM-5010 : U6	HD74LS374FP : U16	HD74HC7268FP : U30	HD74HC564FP : U38	ISS132 : D1-4, 6, 7
HD74LS138FP : U7	HD140668FP : U19	MBM27C64KU : U32	HD74HC244FP : U39	MT2121C : D5

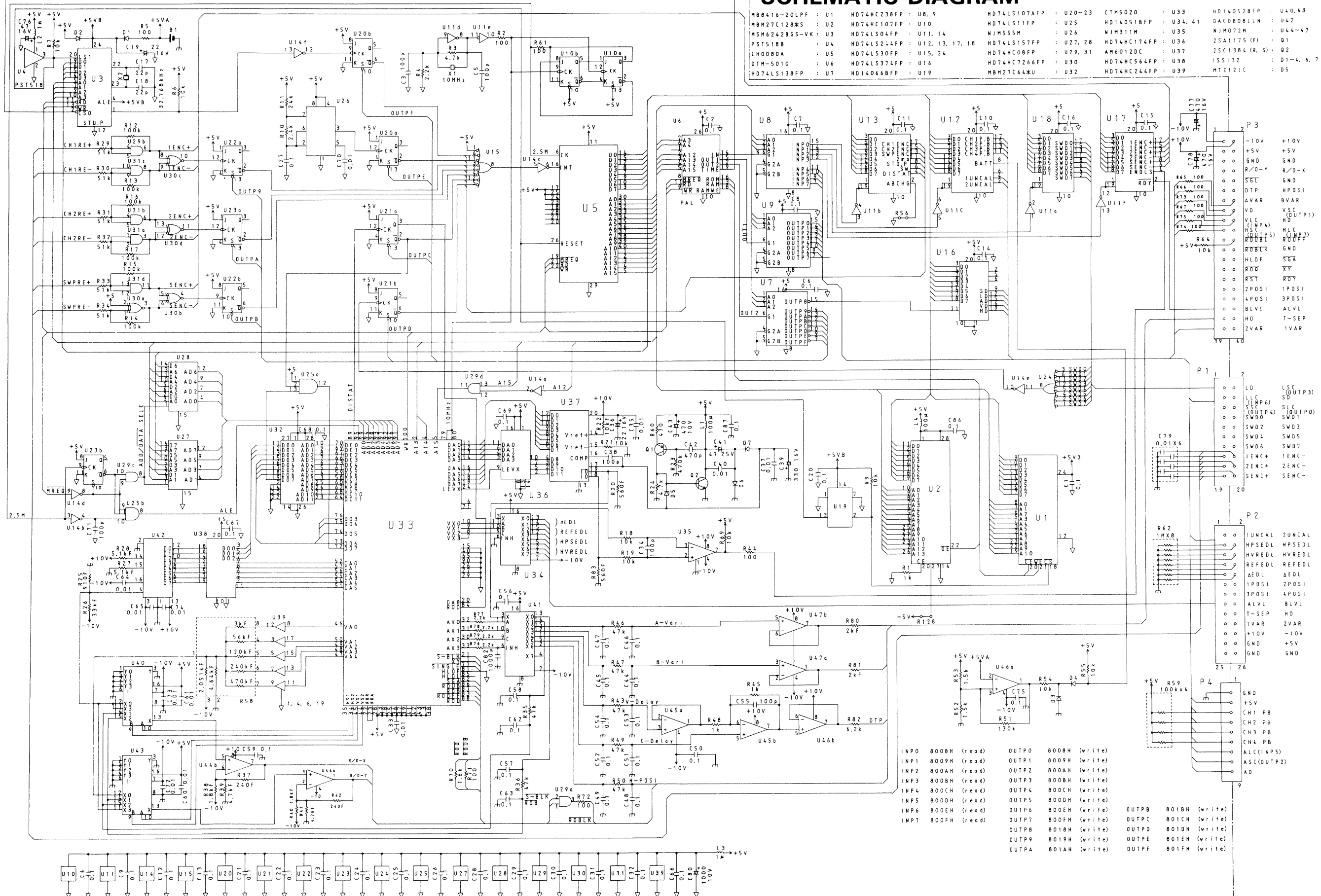

INP0 8008H (read)	OUTP0 8008H (write)	OUTPB 8018H (write)
INP1 8009H (read)	OUTP1 8009H (write)	OUTPC 801CH (write)
INP2 800AH (read)	OUTP2 800AH (write)	OUTPD 801DH (write)
INP3 800BH (read)	OUTP3 800BH (write)	OUTPE 801EH (write)
INP4 800CH (read)	OUTP4 800CH (write)	OUTPA 801AH (write)
INP5 800DH (read)	OUTP5 800DH (write)	
INP6 800EH (read)	OUTP6 800EH (write)	
INP7 800FH (read)	OUTP7 800FH (write)	
	OUTP8 8018H (write)	
	OUTP9 8019H (write)	

FINAL AMP UNIT (X80-1100-00)

SCHEMATIC DIAGRAM

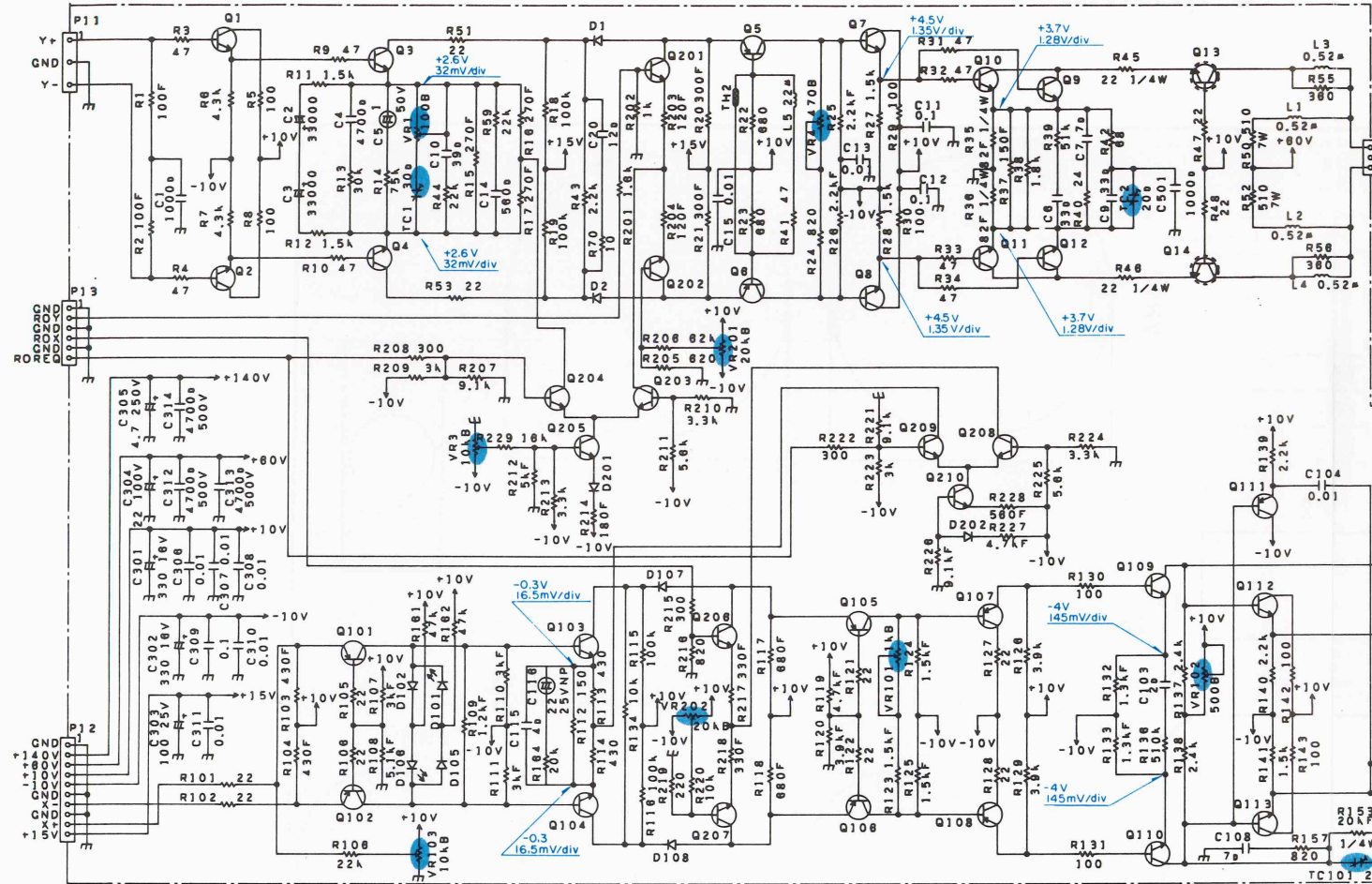

- 2SA1005 (K) : Q101, 102, 105, 108, 107, 108
- 2SA1181 : Q5, 6
- 2SA1208 : Q111
- 2SA1408 : Q118, 117
- 2SC1184 (Q) *S : Q13, 14
- 2SC2785 (F) : Q205, 210
- 2SC3315 (C) : Q103, 104, 201, 202, 208, 207
- 2SC3354 (S, T) : Q109, 110, 112, 113, 203, 204
- : Q208, 209
- 2SC3779 (D) : Q1, 2, 3, 4, 7, 8, 9, 10, 11, 12
- 2SC3800 (E, F) : Q114, 115

- 15S132 : D1, 2, 107, 108, 201, 202
- MA700 : D102, 105
- TLR112 : D101, 108
- SDT100 : TH2

CRT
150YTM31

X81-2330-01 D/4

POWER SUPPLY UNIT (X68-1500-00)

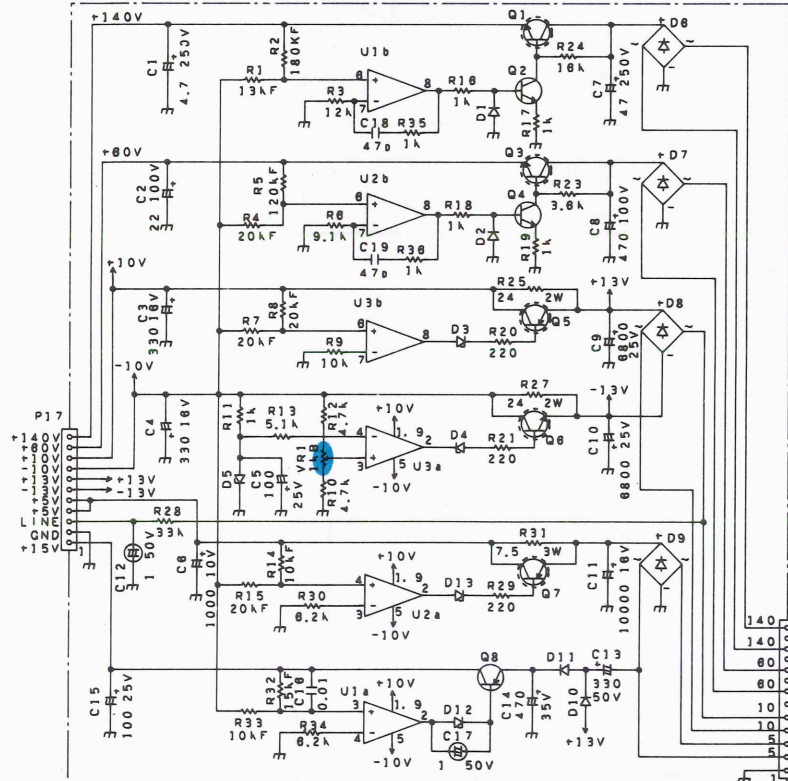

HIGH VOLTAGE UNIT (X68-1510-01)

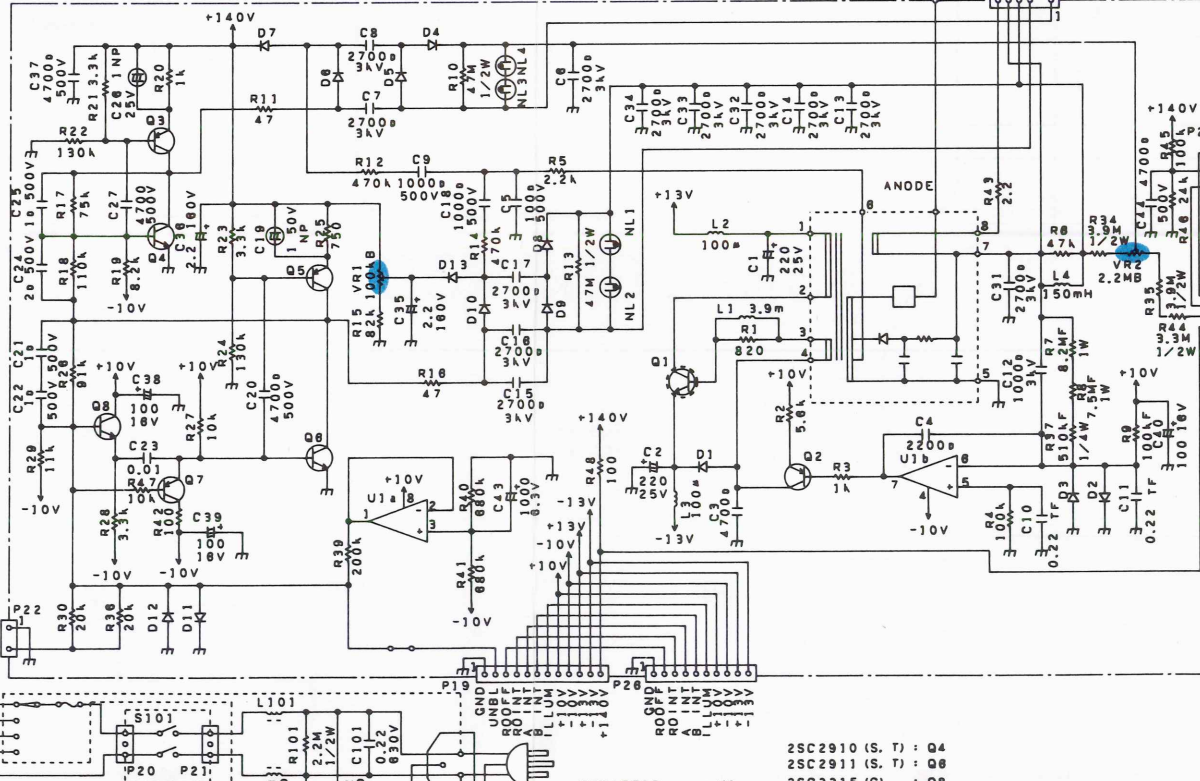

VR UNIT (X81-2330-01 A/4)

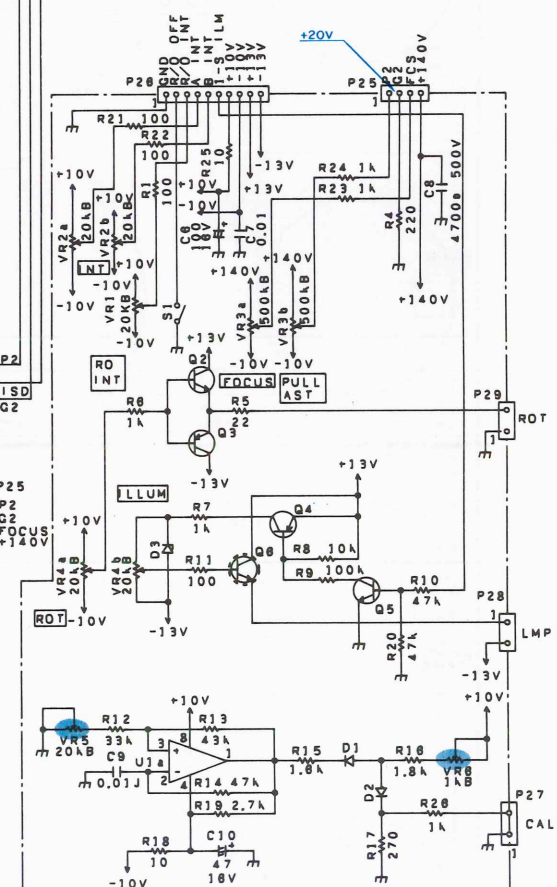

- NJM4558D : U1
- 15S132 : D1, 2
- MTZ5.1JB : D3, 4
- MTZ5.1JB : D5
- MTZ7.5JA : D13
- MTZ20JC : D12
- 1SR35-200A : D10, 11
- 2SC1384 (Q) : Q2
- 2SC2785 (F) : Q5
- 2SD1888 (S) : Q8

- 15S132 : D1, 2
- MTZ13JB : D3, 4
- MTZ5.1JB : D5
- MTZ7.5JA : D13
- MTZ20JC : D12
- 1SR35-200A : D10, 11
- S1V880 : D8, 7
- S4V840F : D8, 9
- NJM4558S : U1, 2, 3
- 2SA884 (Q) : Q8
- 2SB1133 (S) : Q5, 7
- 2SC2271 (D) : Q2, 4
- 2SD1409 : Q1, 3
- 2SD1888 (S) : Q8

- X81-2330-01 C/4
- X81-2330-01 B/4

- NJM4558D : U1
- 2SD813 (E) : Q1
- 2SA1175 (F) : Q2, Q7
- 2SA1208 (S, T) : Q3
- 2SA1209 (S, T) : Q5
- 2SC2910 (S, T) : Q4
- 2SC2911 (S, T) : Q6
- 2SC3315 (C) : Q8
- 1SR35-200 : D4, 5, 8, 9
- 15S83 : D6, 7, 10, 13
- 15S132 : D1, 2, 3, 11, 12
- NE-2B : NL1-4

P.C BOARD

PANEL UNIT (X66-1050-00)

Pattern side view

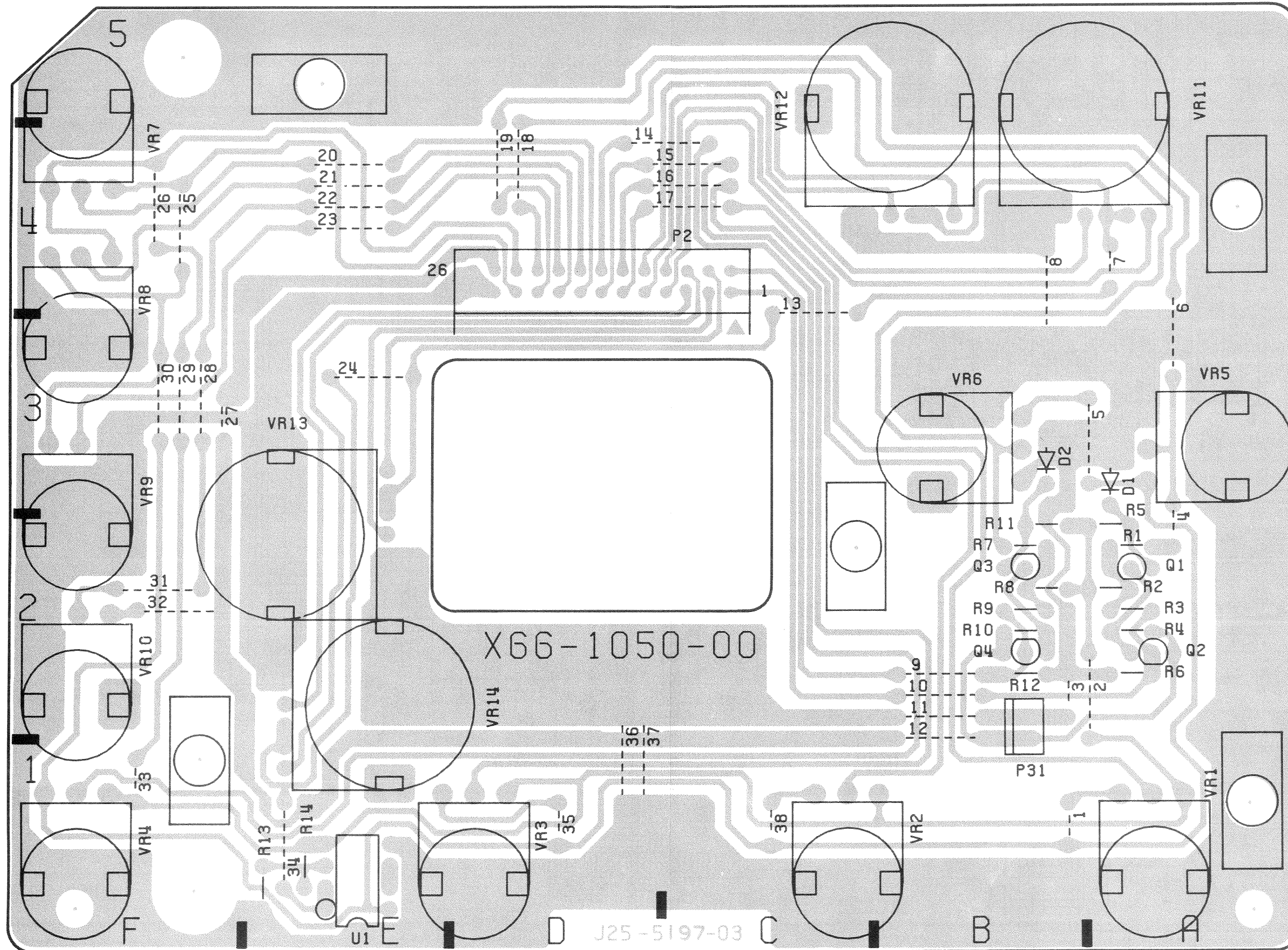

P.C BOARD

POWER SUPPLY UNIT (X68-1500-00)

HIGH VOLTAGE UNIT (X68-1500-01)

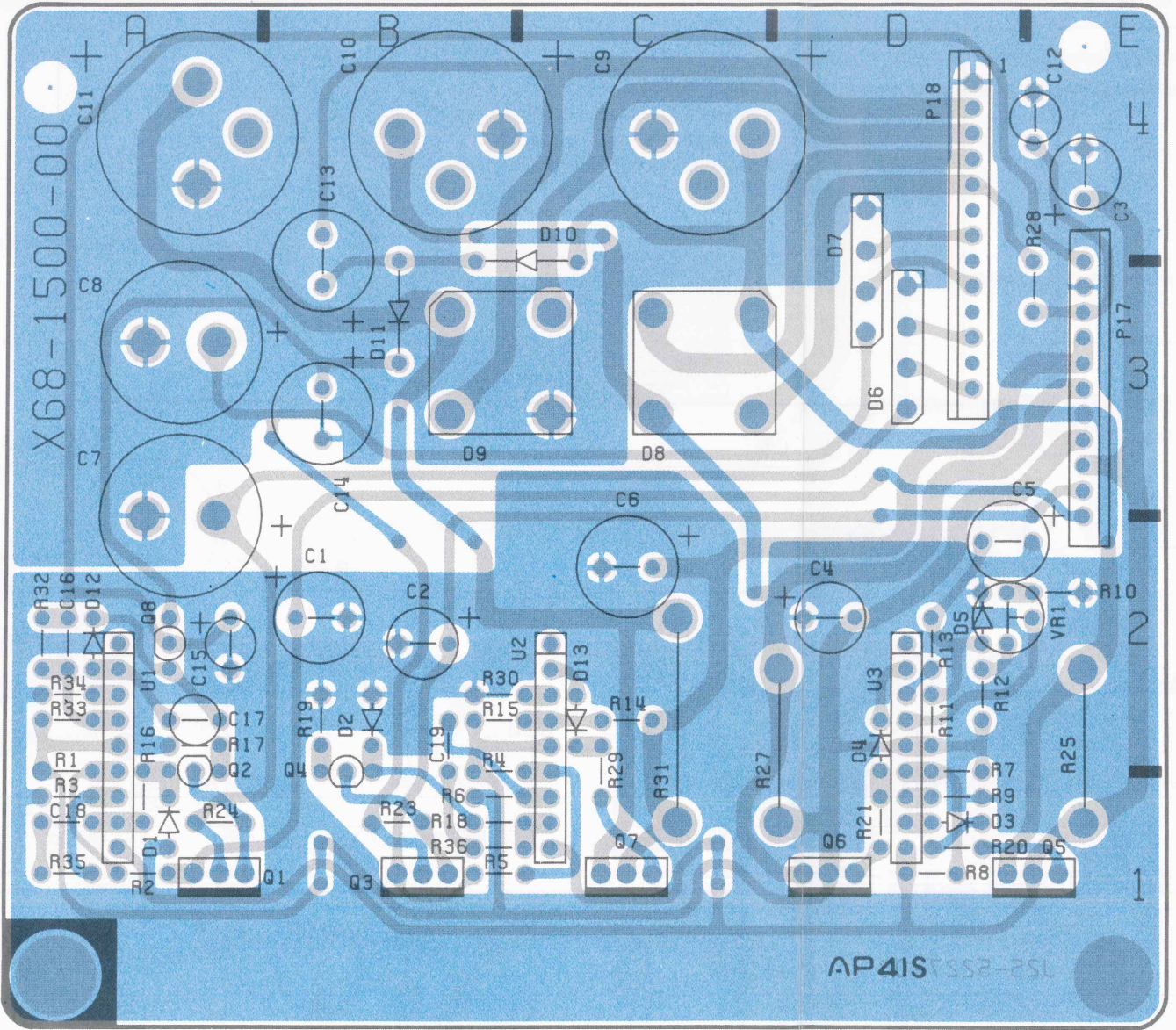

P.C BOARD

HIGH VOLTAGE UNIT (X68-1510-01)

Pattern side view

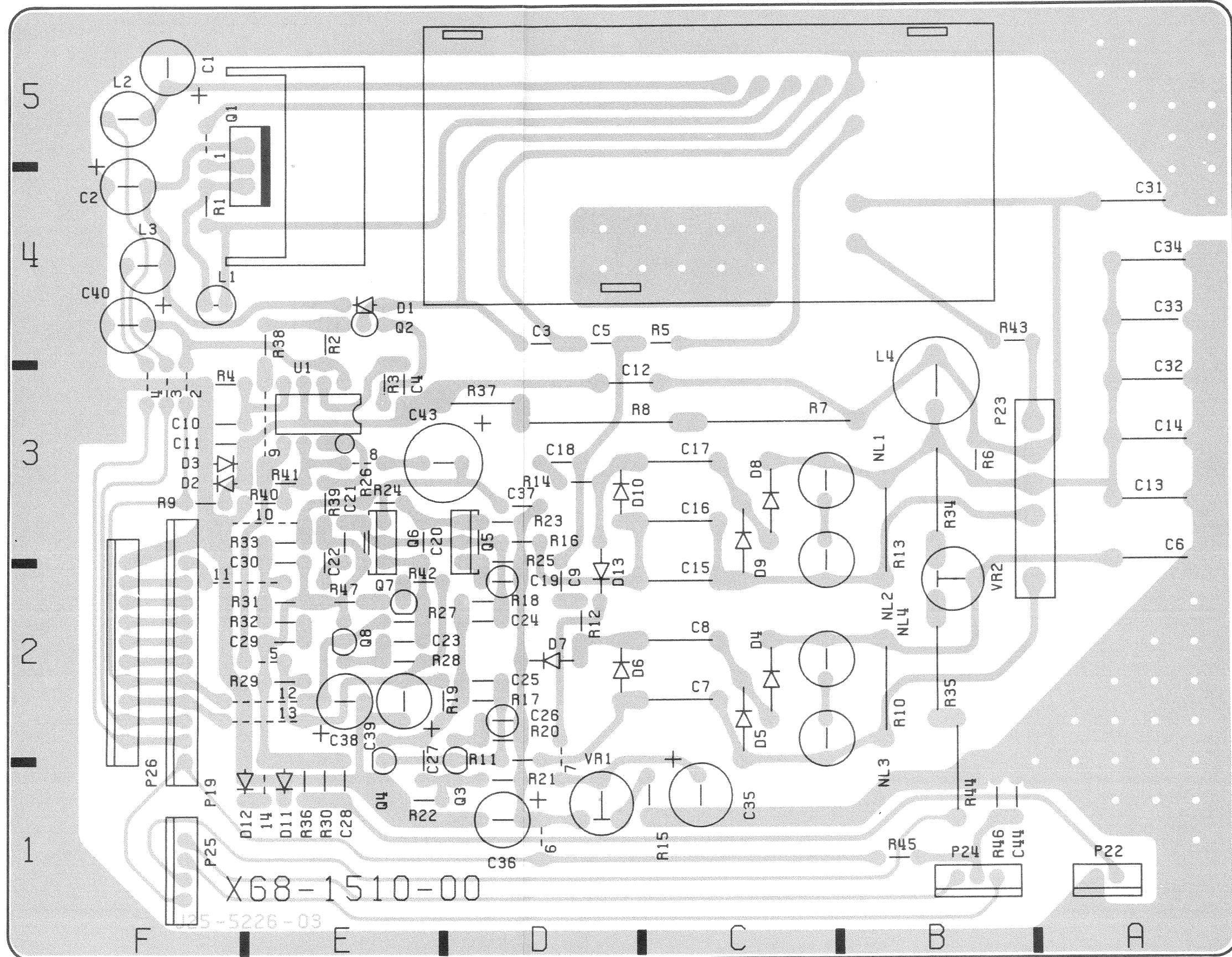

P.C BOARD

SWITCH UNIT (X69-1150-01)

Pattern side view

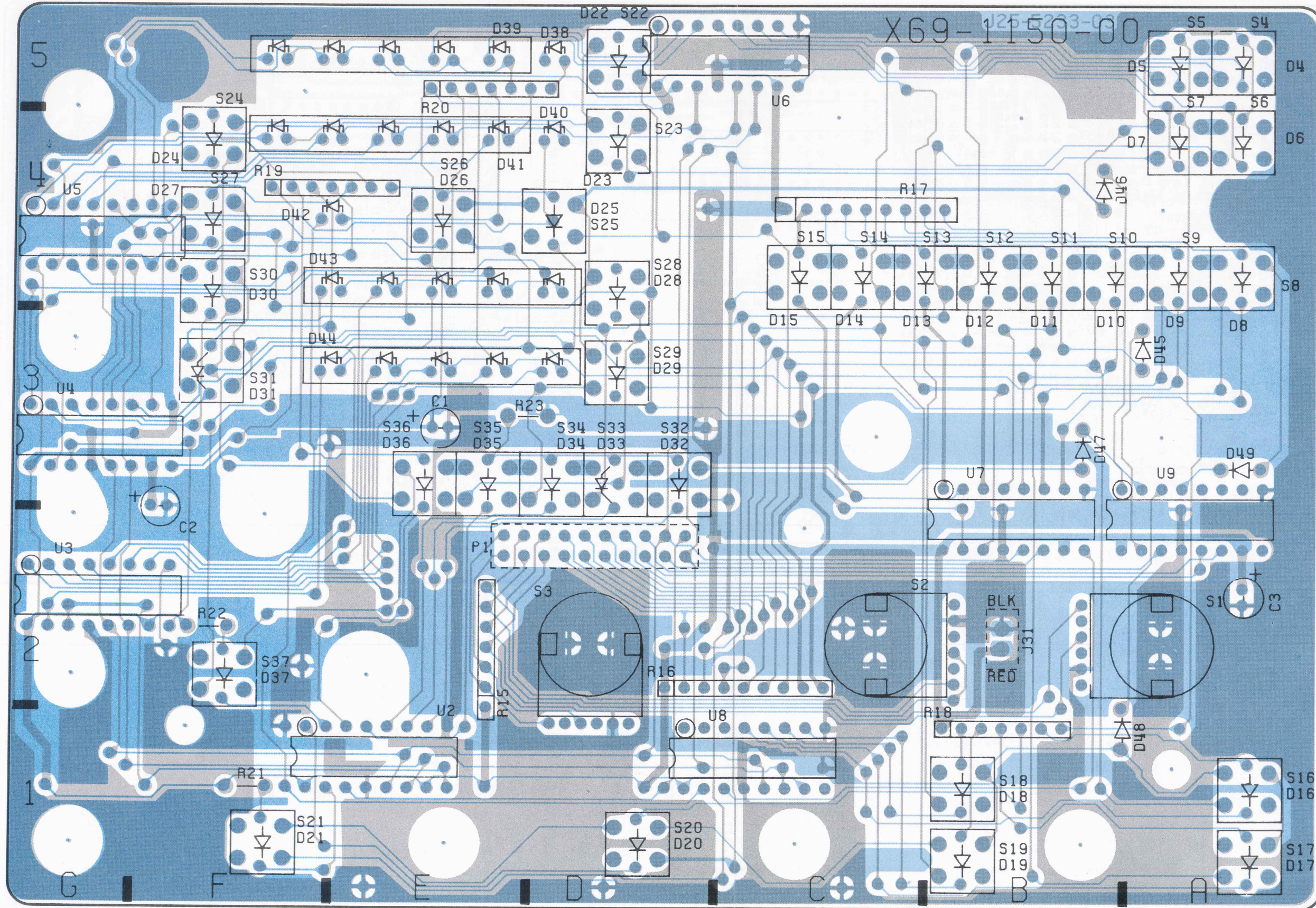

P.C BOARD

VERTICAL PREAMP UNIT (X73-1760-00)

SWITCH UNIT (X73-1760-00)

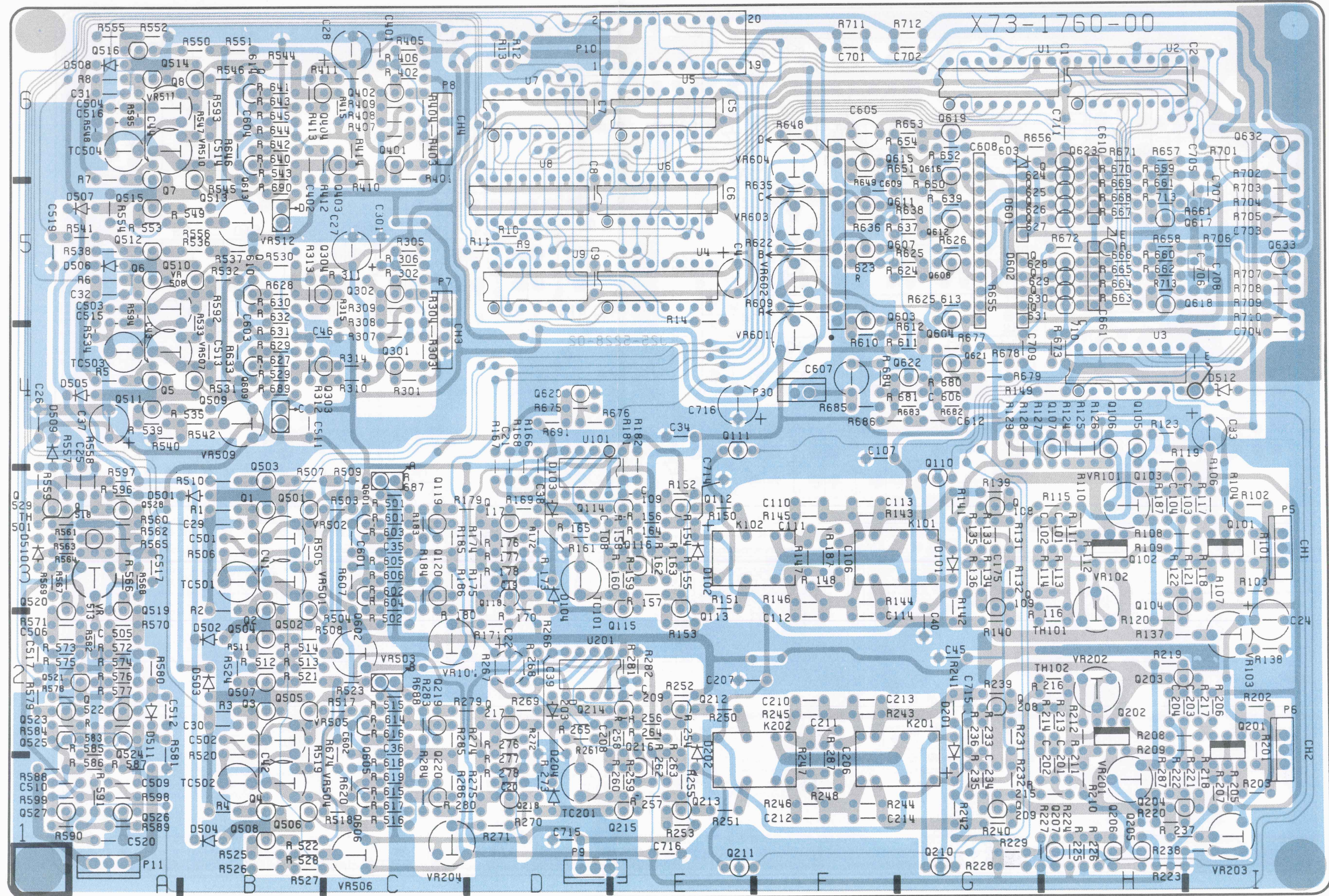

P.C BOARD

HORIZONTAL UNIT (X74-1480-01)

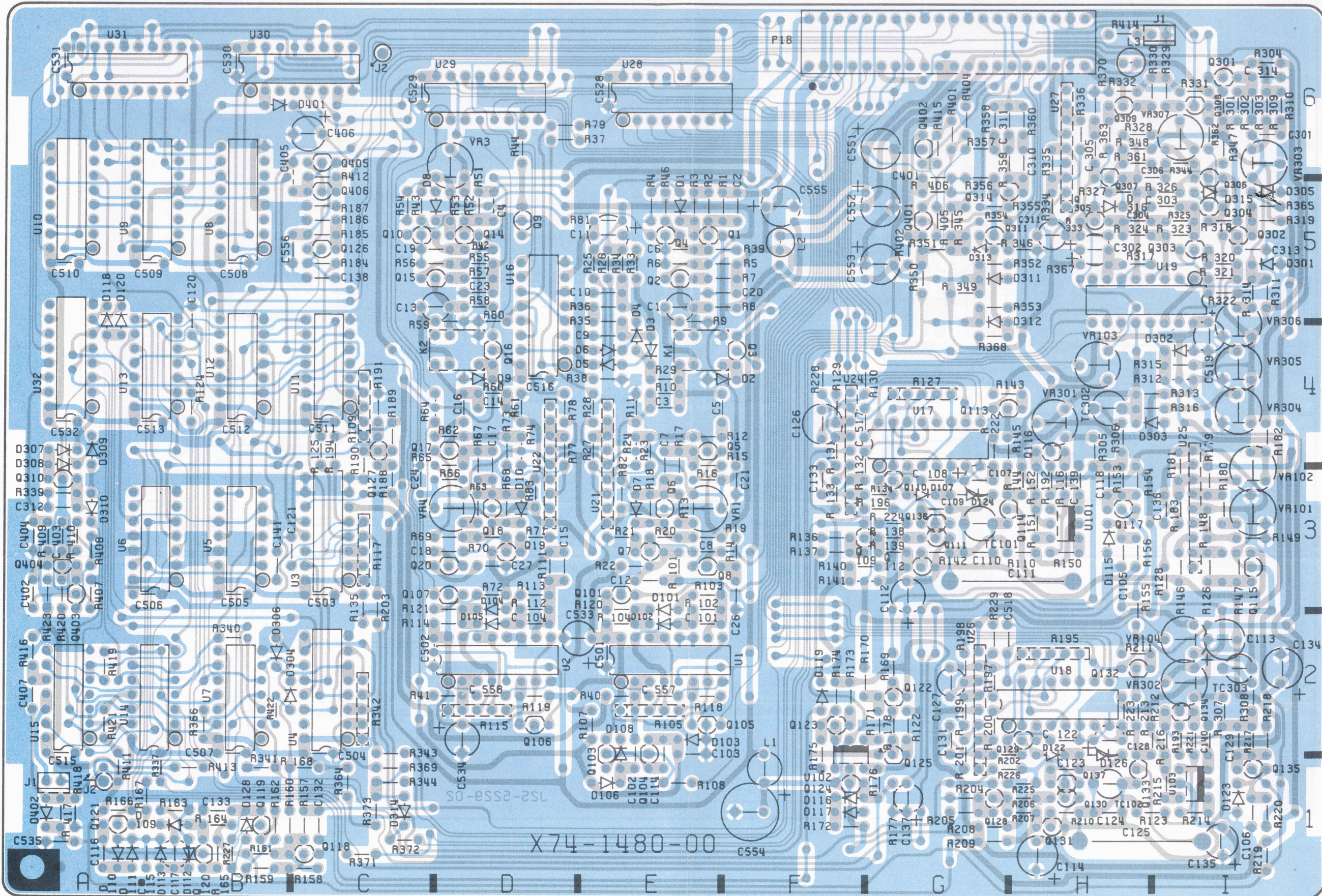

P.C BOARD

R/O UNIT (X77-1490-00)

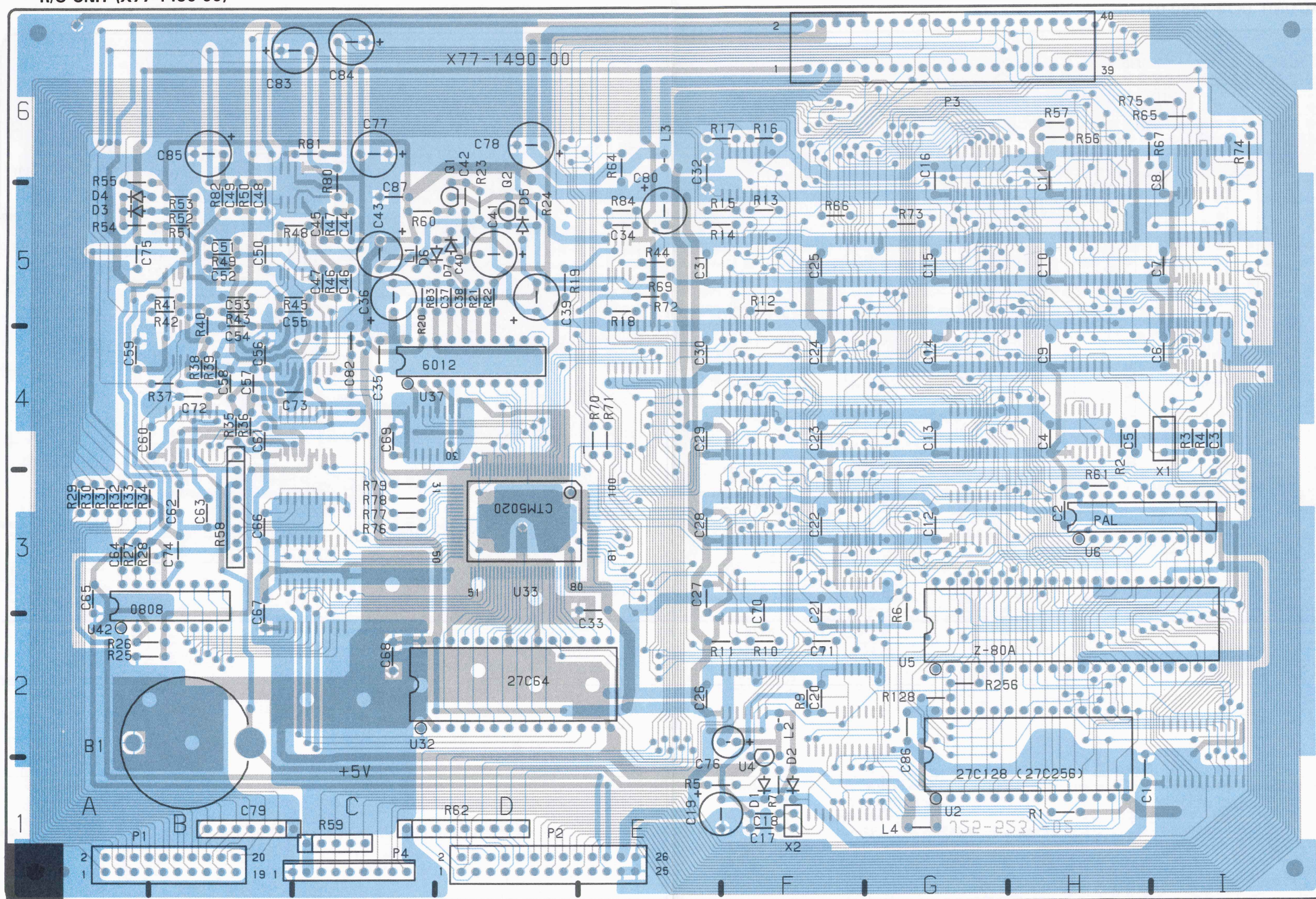

P.C BOARD

R/O UNIT (X77-1490-00)

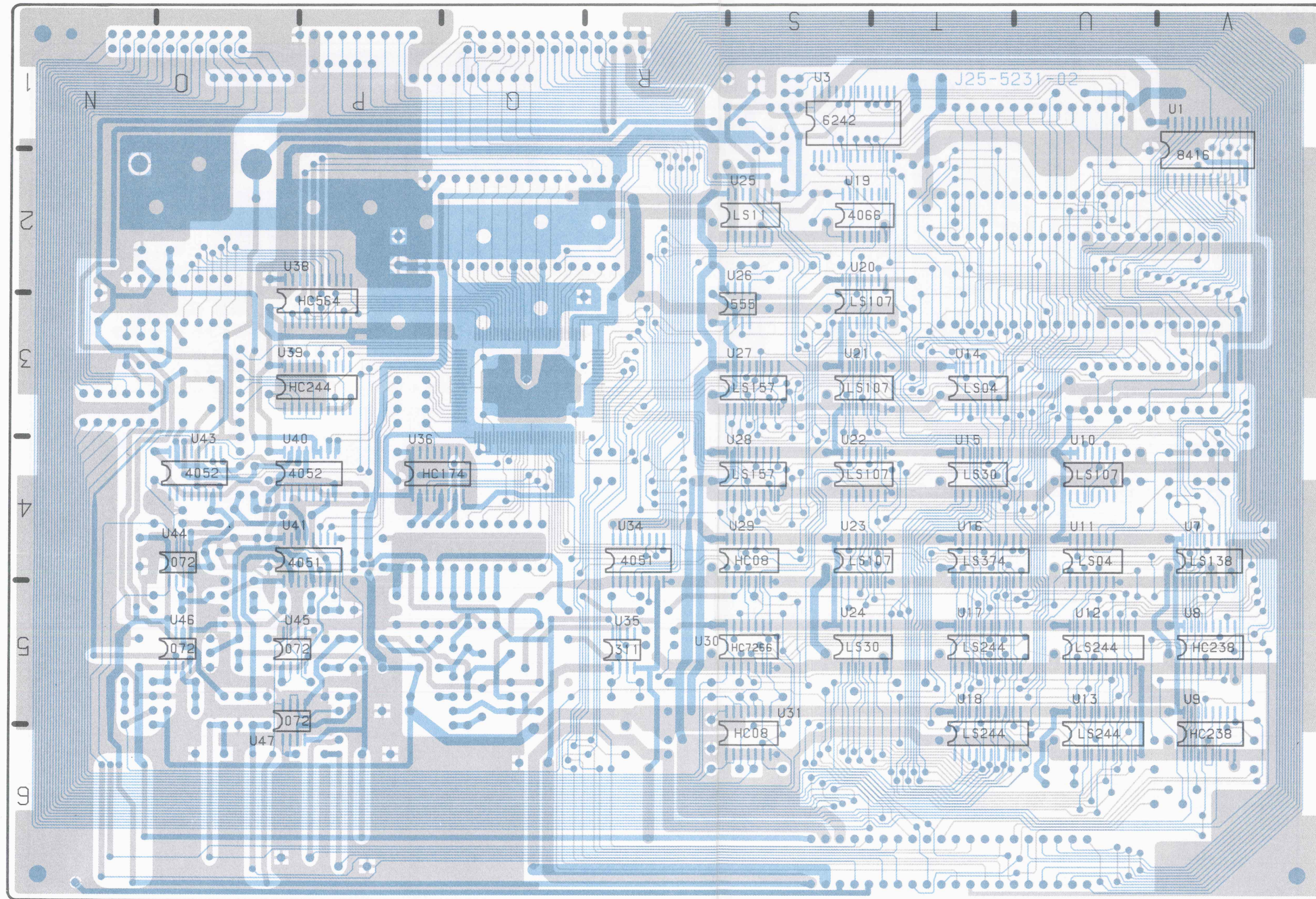

P.C BOARD

ATT UNIT (X75-1180-00)

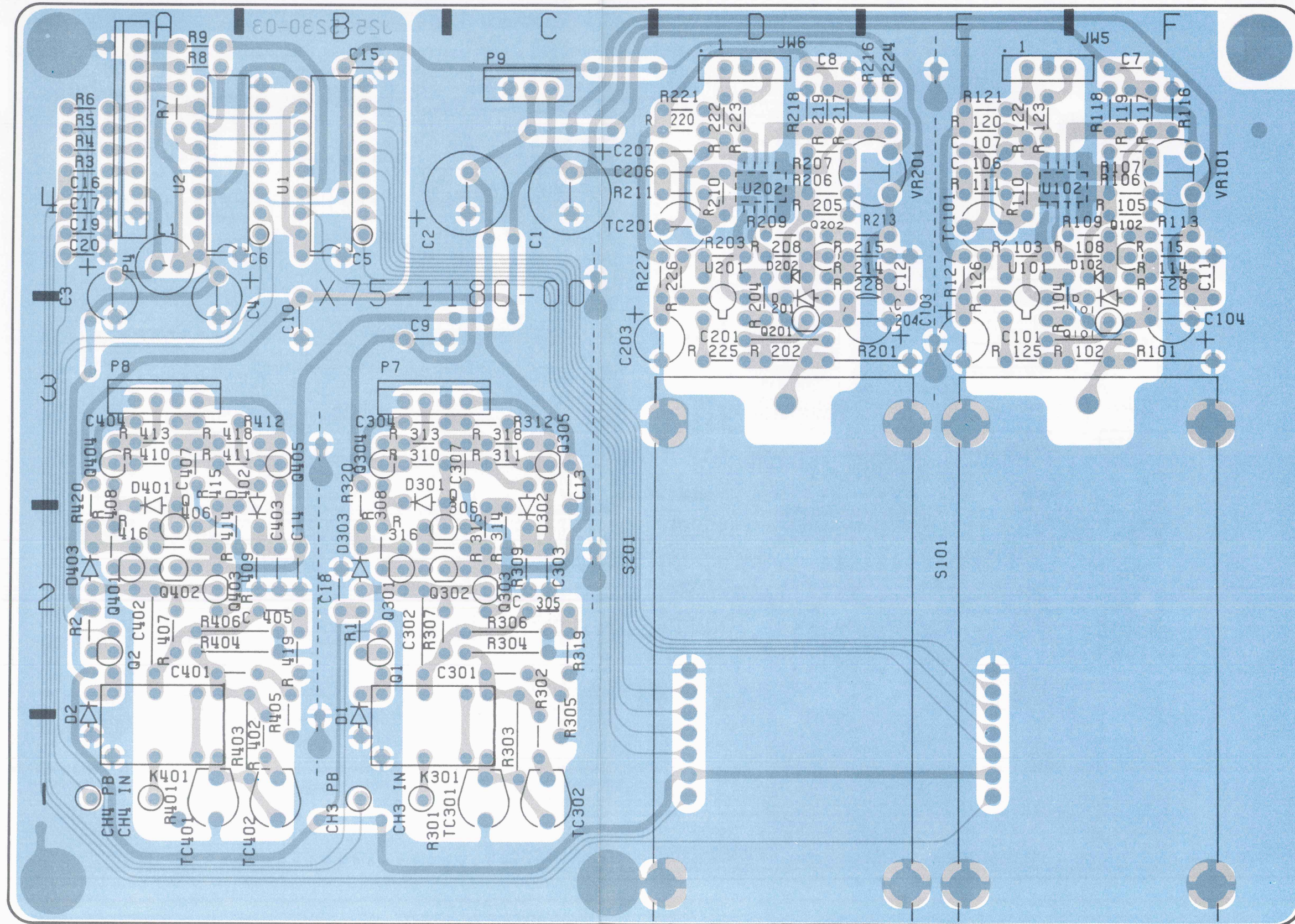

P.C BOARD

CONNECTION UNIT (X77-1500-00)

(TO 0011-08X) THIS UNIT

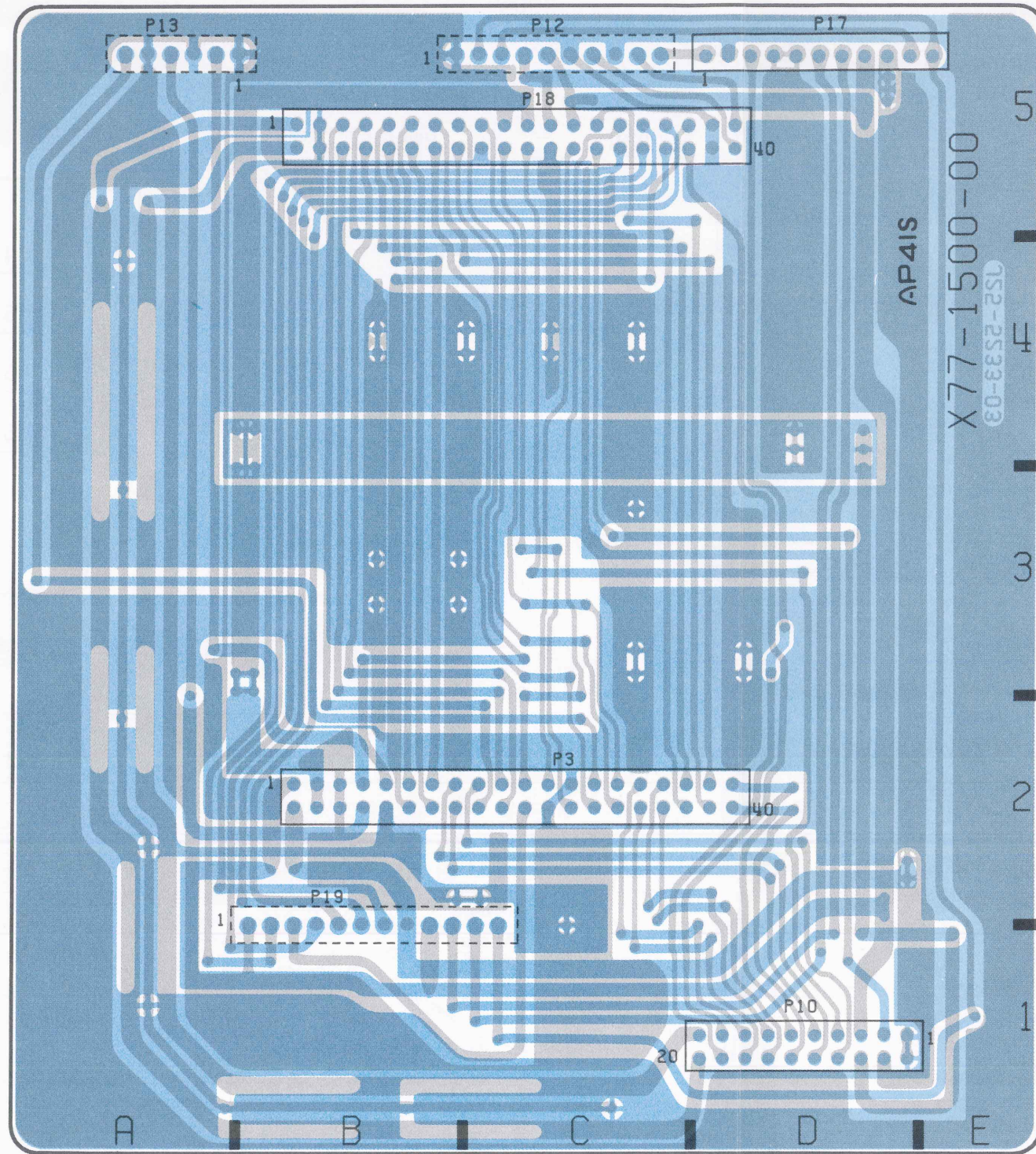

P.C BOARD

FINAL UNIT (X80-1100-01)

CONNECTION UNIT (X77-1500-00)

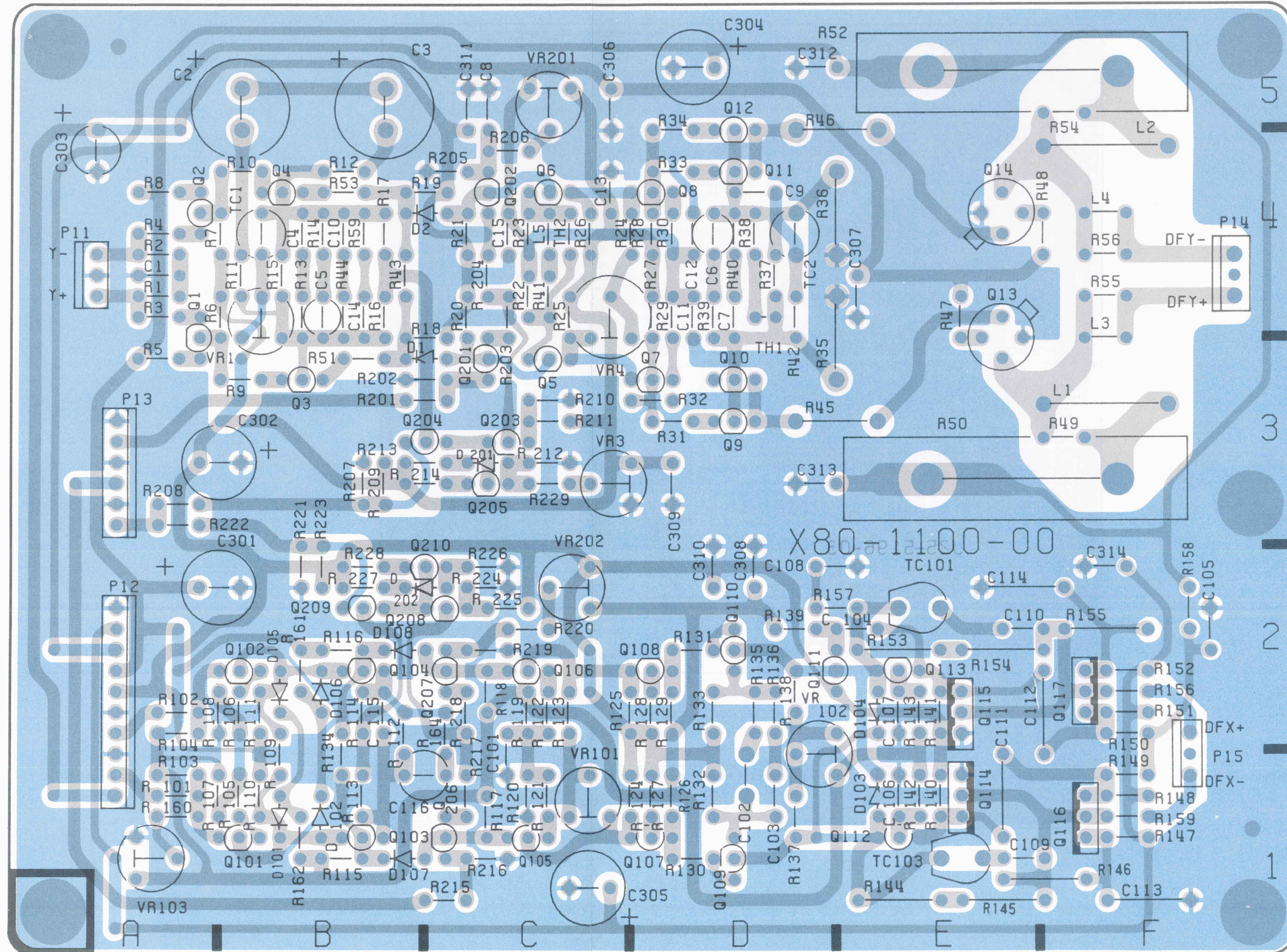

P.C BOARD

VOLUME UNIT (X81-2330-01)

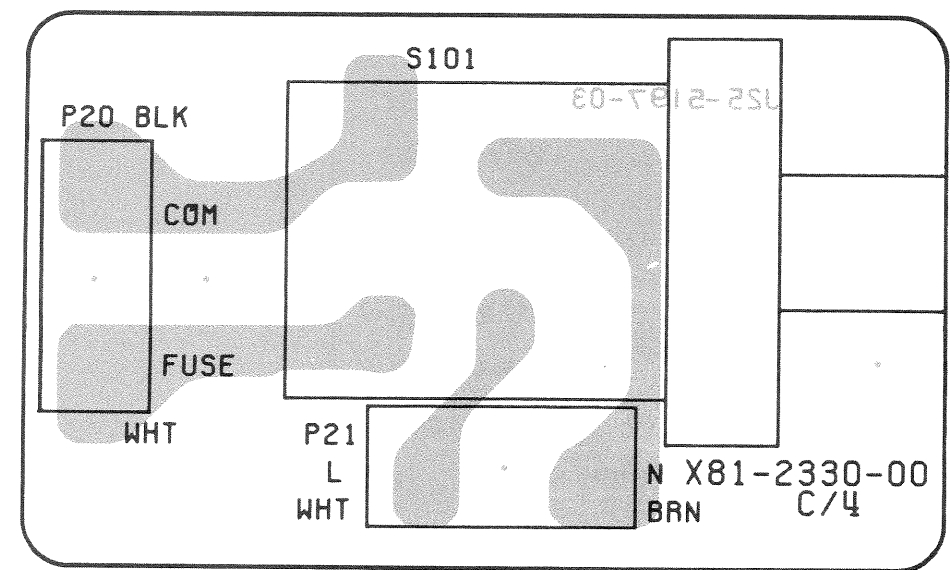
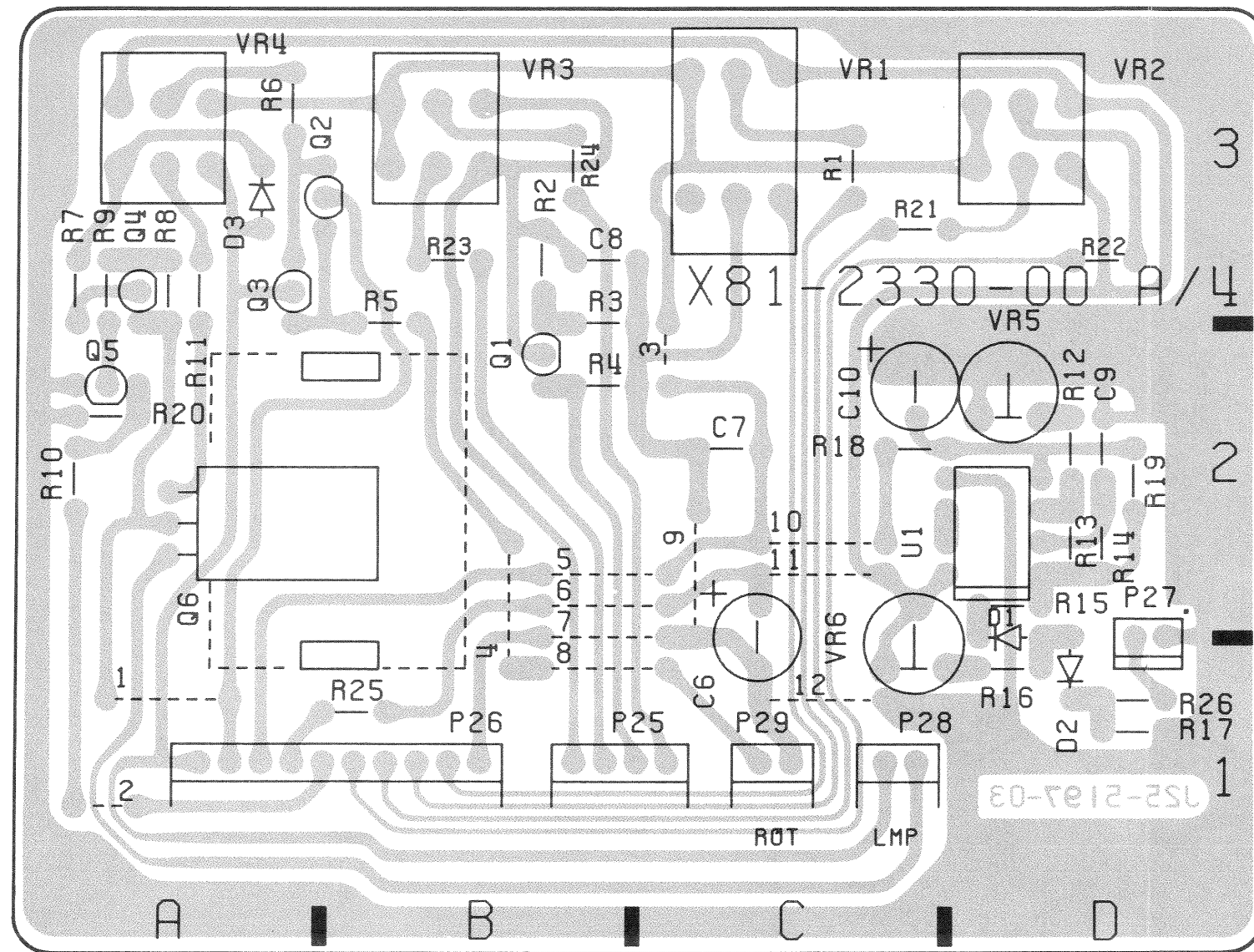



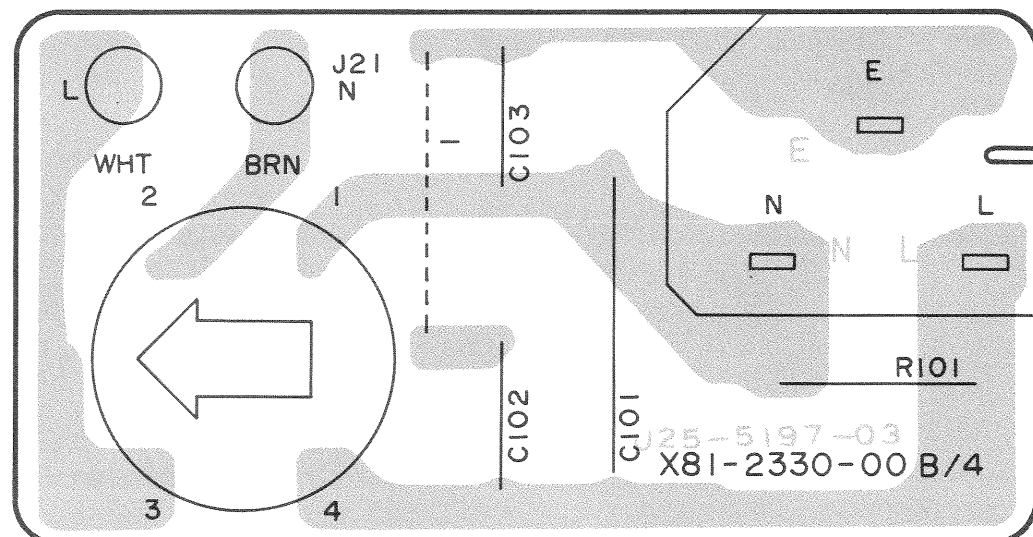
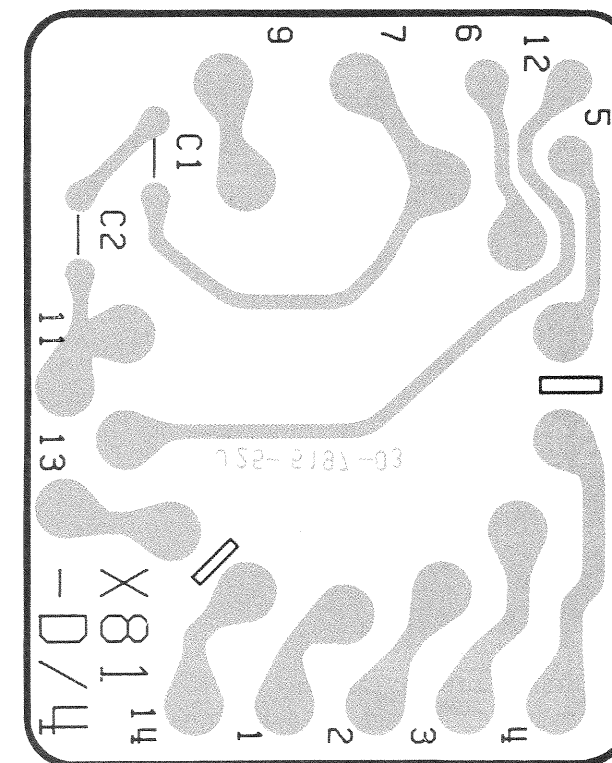







CRT SOCKET



Pattern side view

DISASSEMBLY

Parts No.	Parts Name	Figure
A N08-0611-04	Cord wrapping screw	
B N09-0705-05	Hexagon socket flat head screw (M4×8)	
C N09-0718-05	Sems screw (M3×6)	
D N09-0739-05	Sems taptite screw (3×8)	
E N09-0720-05	Sems screw (M4×10)	
F N09-0733-15	Sems screw (M3×20)	
G N32-3008-41	Flat head screw (M3×8)	
H N88-3008-41	Flat head taptite screw (3×8)	
I N89-3008-41	Binding head taptite screw (3×8)	
J N35-3006-41	Binding head screw (M3×6)	
K N09-0731-05	Sems screw (M3×12)	

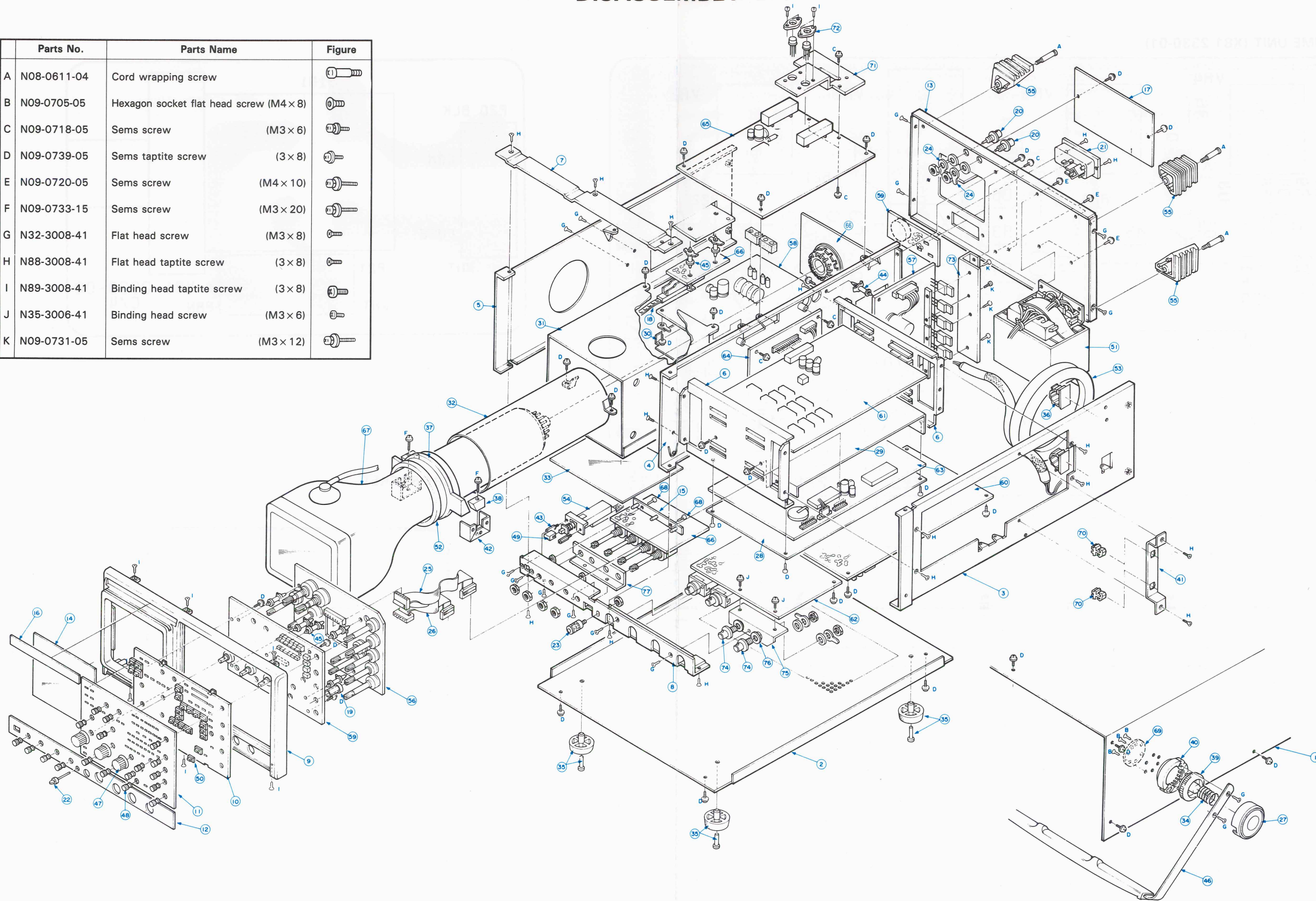

SEMICONDUCTORS

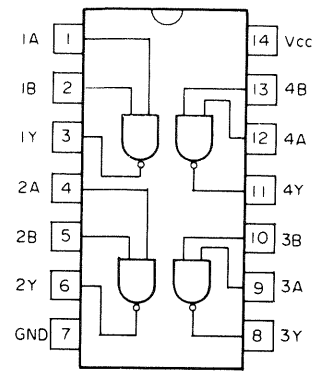

SN74ALS00AN

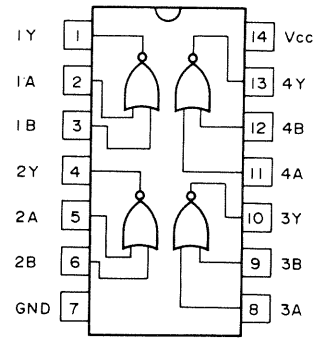

SN74ALS02N

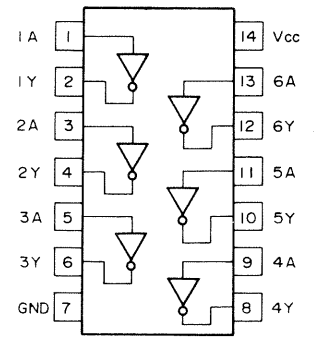

HD74LS04FP

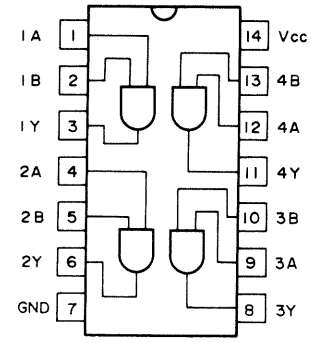

SN74ALS08N
HD74HC08FP

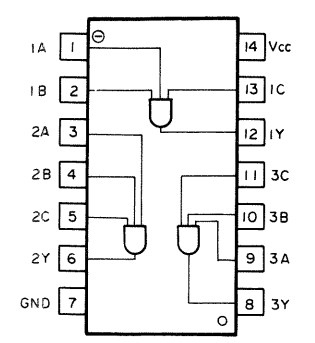

HD74LS11FP

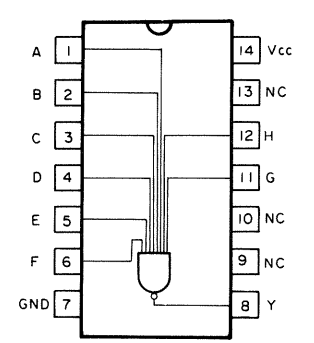

HD74LS30FP

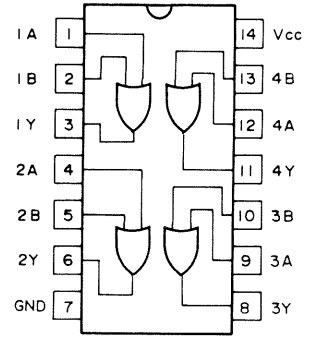

SN74ALS32N

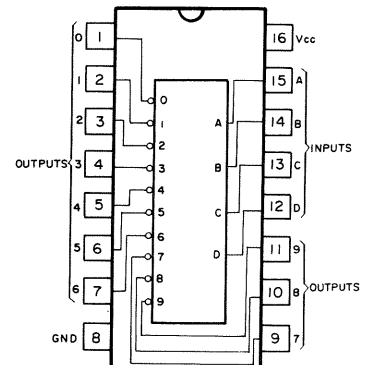

HD74LS42P

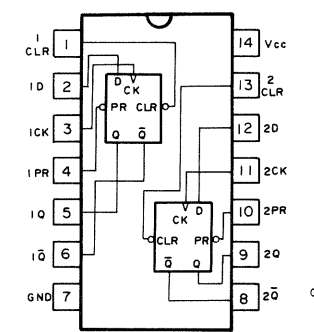

SN74ALS74AN

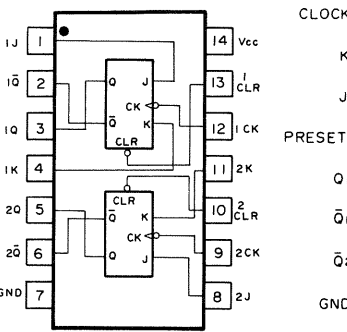

HD74LS107AFP
HD74HC107FP

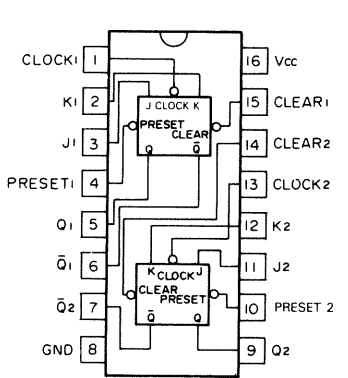

SN74ALS112AN

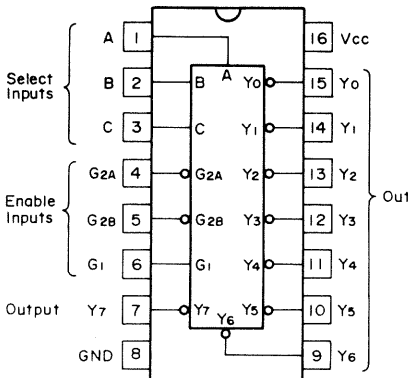

HD74LS138FP

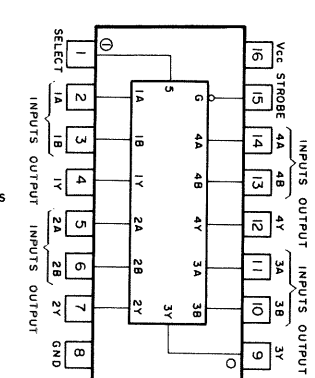

HD74LS157FP

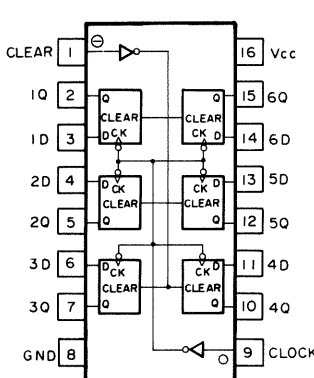

HD74HC174FP

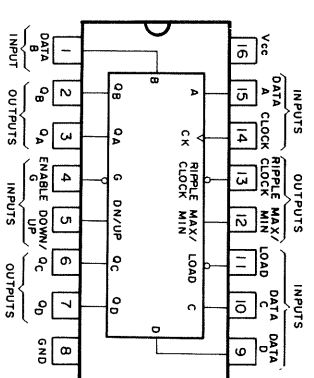

SN74ALS191N

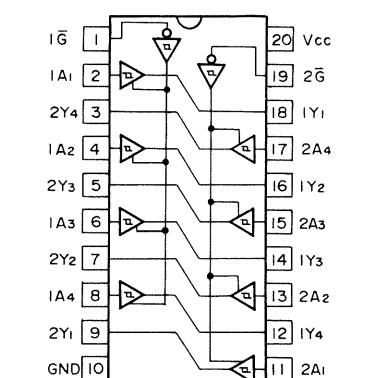

HD74LS244FP

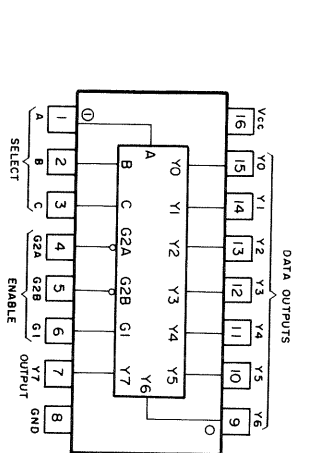

HD74LS374FP

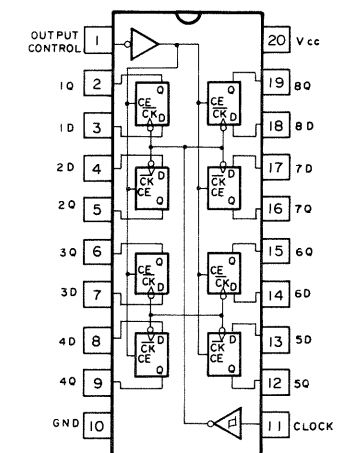

HD74HC238FP

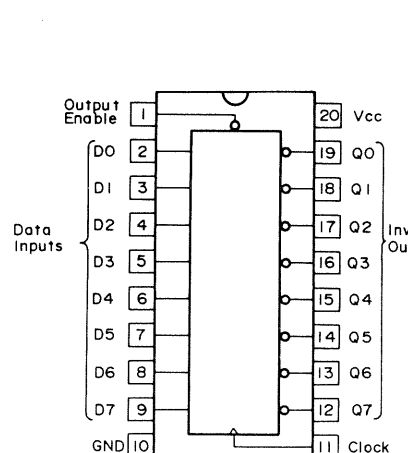

HD74HC564FP

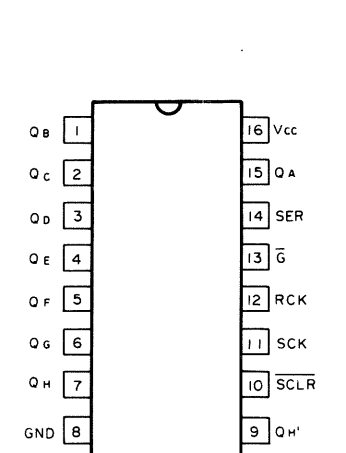

HD74HC595P

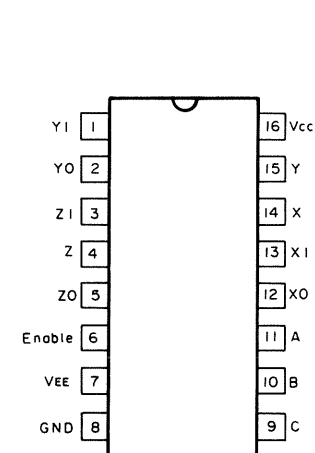

MC74HC4053N

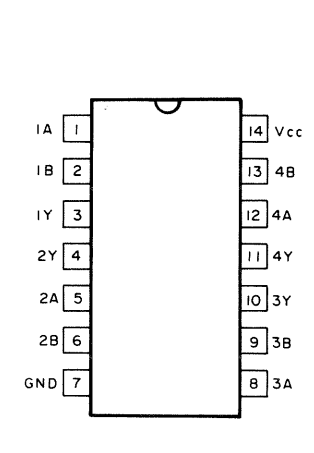

HD74HC7266FP

SEMICONDUCTORS

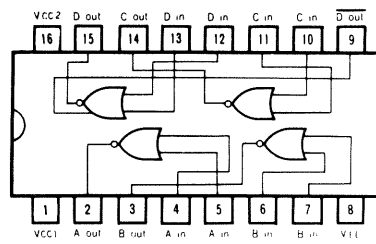

MC10H102L

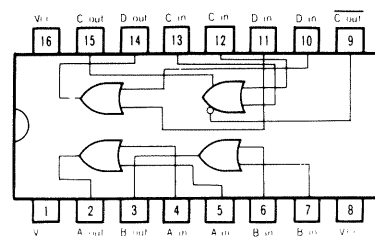

MC10103L

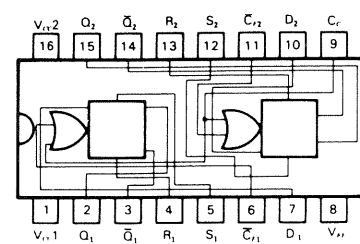

MC10H131L

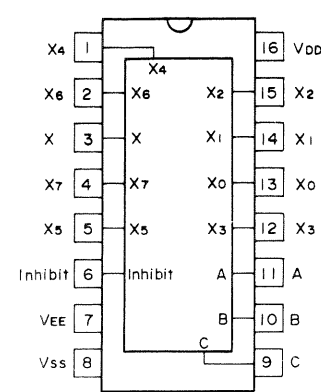

HD14051BFP

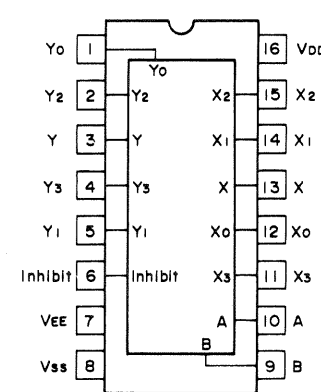

HD14052BFP
MC14052BCP

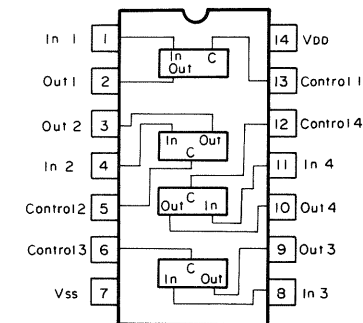

HD14066BFP

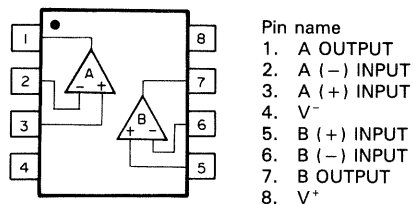

NJM072M

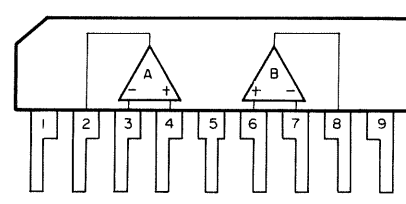

NJM072S

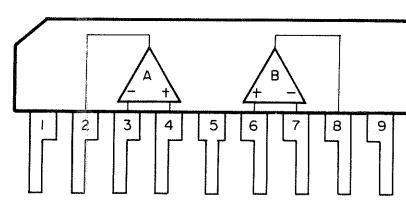

NJM4556S

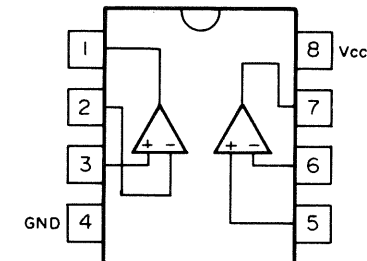

NJM4558D

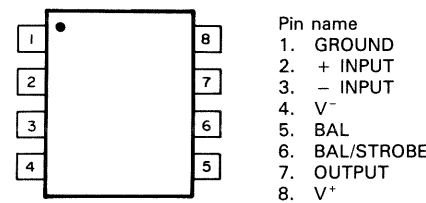

NJM311M

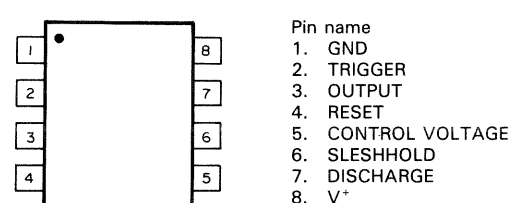

NJM555M

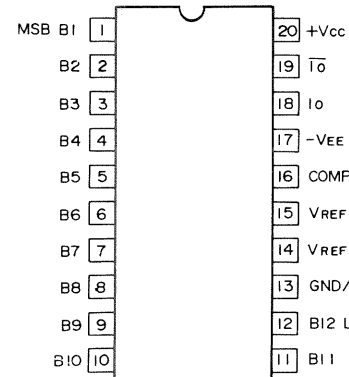

AM6012DC

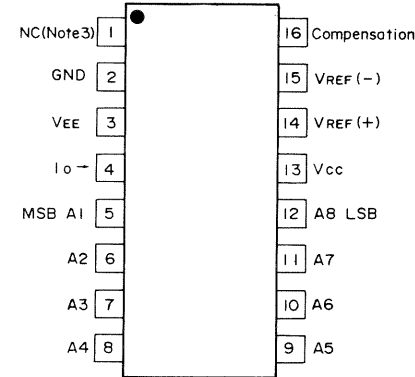

DAC0808LCN

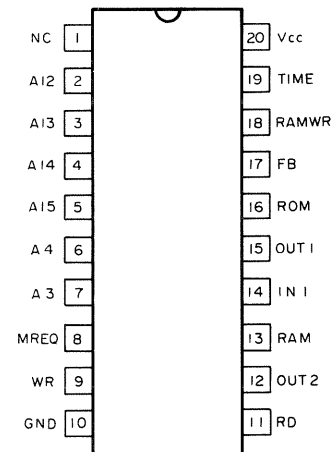

DTM-5010

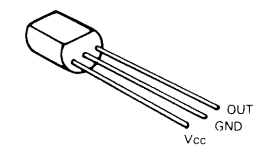

PST518B

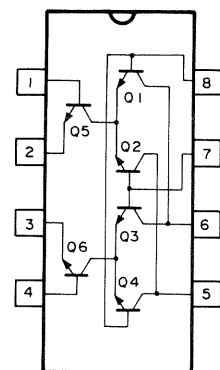

μPA101G

SEMICONDUCTORS

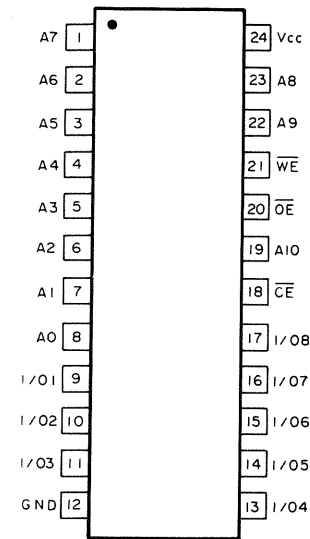

LC3517BML-15

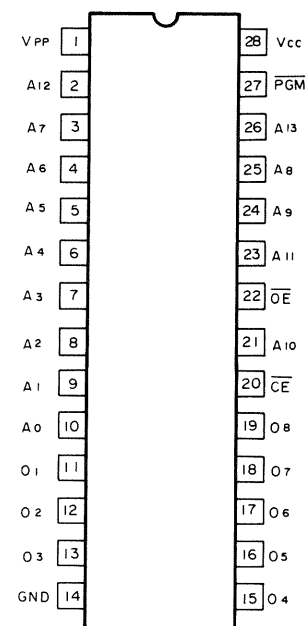

MBM27C128*S

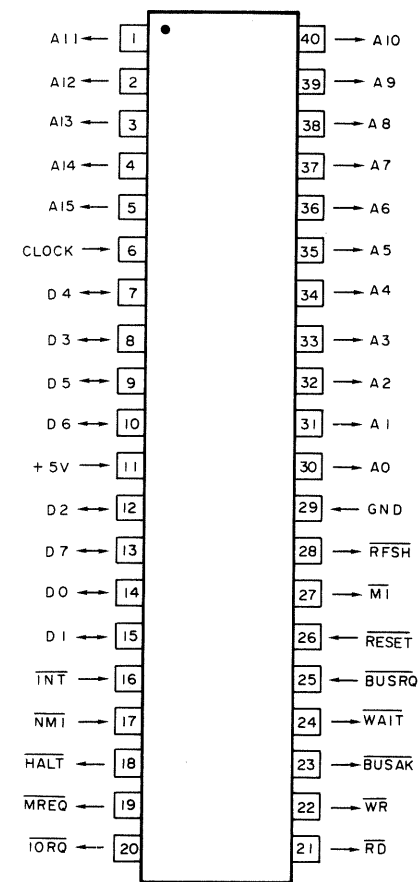

LH0080A

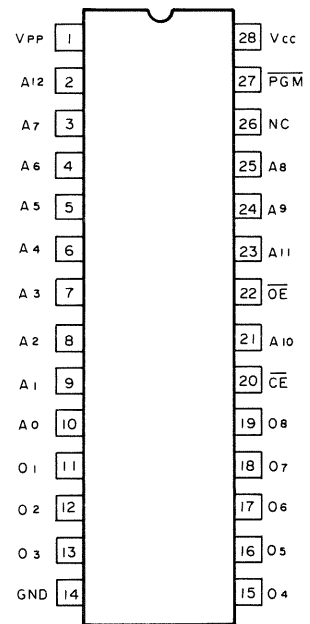

MBM27C64*U

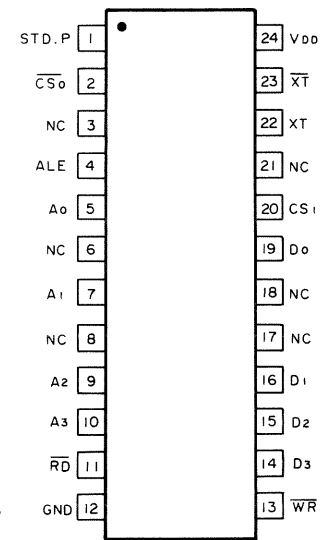

MSM6242BGS-VK

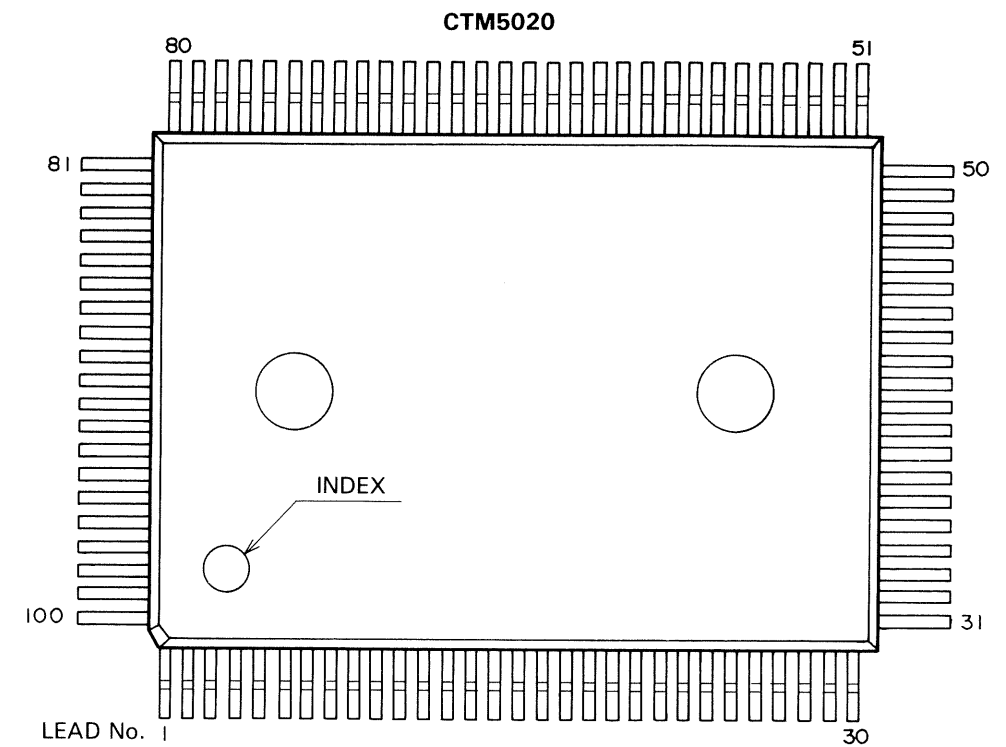

Pin No.	Pin Name	Pin No.	Pin Name	Pin No.	Pin Name	Pin No.	Pin Name
1	CONT	26	TSD0	51	GETD	76	DD3
2	A13	27	TSD1	52	CA0	77	SING
3	VDD	28	VDD	53	VDD	78	VDD
4	A14	29	TSD2	54	CA4	79	R10M
5	A15	30	AX2	55	CA3	80	10M
6	INT0	31	AX1	56	CA2	81	HLDF
7	VX3	32	AX0	57	CA1	82	SGA
8	VX2	33	AX3	58	CD3	83	ROSP
9	VX1	34	HS2	59	CD2	84	ROD
10	VX0	35	HS1	60	CD4	85	HLDL
11	DA0	36	TDIO	61	CD1	86	ROUB
12	DA1	37	TWE	62	CD5	87	ROB
13	DA2	38	TCK1	63	DC4	88	ROQ
14	DA3	39	TST1	64	CD7	89	ROED
15	VSS	40	VSS	65	VSS	90	VSS
16	DA4	41	TST2	66	DC3	91	D7
17	DA5	42	TADD	67	DC2	92	D5
18	DA6	43	TCK2	68	CD6	93	D3
19	DA7	44	VS2	69	DC1	94	D1
20	DA8	45	VS1	70	DC0	95	ALE
21	DA9	46	VA0	71	CD0	96	D6
22	ROR	47	VA4	72	DD7	97	D4
23	ROA	48	VA3	73	DD6	98	D2
24	LEVX	49	VA2	74	DD5	99	D0
25	TCL	50	VA1	75	DD4	100	WR

SEMICONDUCTORS

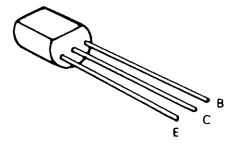

2SA684 (Q)
2SA1208 (S, T)
2SC2271 (D)
2SC2910 (S, T)
2SC1384 (R, S)

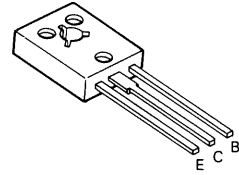

2SA1209 (S, T)
2SA1406 (E, F)
2SC2911 (S, T)
2SC3600 (E, F)

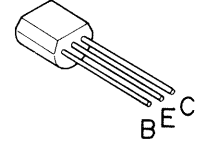

2SA1161
2SC3779 (D)

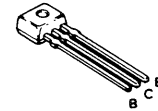

2SA1175 (E)
2SC2785 (F)
2SC3732 (L)

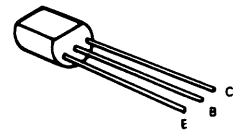

2SA1206

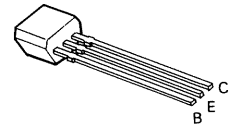

2SA1565
2SC4049

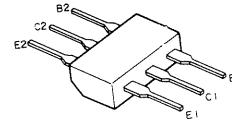

2SC4072
2SC3066 (F)

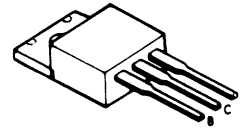

2SB1133 (S)
2SD1666 (S)

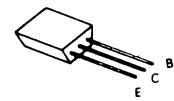

2SC3354 (T, S)

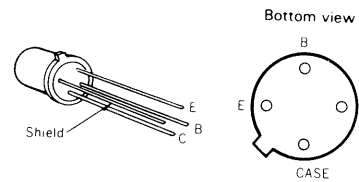

2SC1164 (O)*S

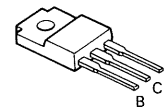

2SD1409

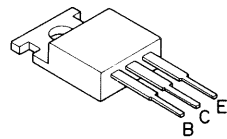

2SD613 (E)

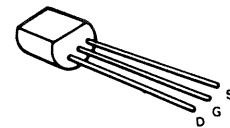

2SK583

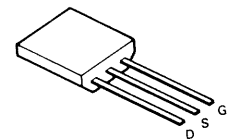

2SK241 (GR)

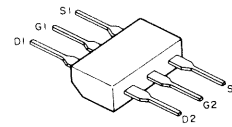

2SK332 (F)

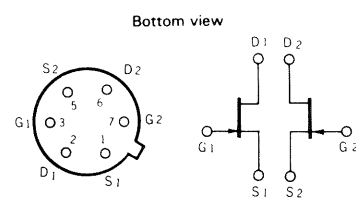

DN1901

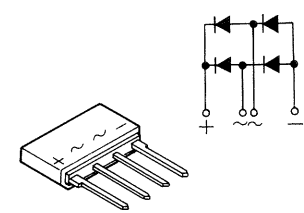

S1VB60

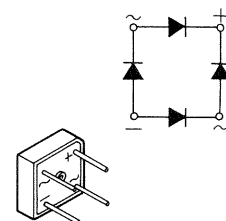

S4VB40F

A product of
KENWOOD CORPORATION
17-5, 2-chome, Shibuya, Shibuya-ku, Tokyo 150, Japan